



PDHengineer.com

Course № C-8002

Design of Conduits, Culverts and Pipes

Document 2 of 2: Appendices



This document is the course text. You may review this material at your leisure before or after you purchase the course. If you have not already purchased the course, you may do so now by returning to the course overview page located at:

<http://www.pdhengineer.com/pages/C-8002.htm>

(Please be sure to capitalize and use dash as shown above.)

Once the course has been purchased, you can easily return to the course overview, course document and quiz from PDHengineer's My Account menu.



If you have any questions or concerns, remember you can contact us by using the Live Support Chat link located on any of our web pages, by email at administrator@PDHengineer.com or by telephone toll-free at 1-877-PDHengineer.

Thank you for choosing PDHengineer.com.



17350 State Highway 249 | Suite 140 | Houston, TX 77064

Appendix A References

A-1. Required Publications

EM 1110-2-1603

Hydraulic Design of Spillways

EM 1110-2-1913

Design and Construction of Levees

EM 1110-2-2102

Waterstops and Other Joint Materials

EM 1110-2-2104

Strength Design for Reinforced-Concrete Hydraulic Structures

EM 1110-2-2400

Structural Design of Spillways and Outlet Works

EM 1110-2-2901

Tunnels and Shafts in Rock

Note: Specifications are grouped by issuing agency and then arranged in numerical order by specification designation.

American Association of State Highway & Transportation Officials (AASHTO) 1996

American Association of State Highway & Transportation Officials. 1996. *Standard Specifications for Highway Bridges*, Sixteenth Edition, Washington, DC.

American Association of State Highway & Transportation Officials (AASHTO)

American Association of State Highway & Transportation Officials, *M36/M36M, Standard Specification for Corrugated Steel Pipe, Metallic-Coated, for Sewers and Drains*, Washington, DC.

American Association of State Highway & Transportation Officials (AASHTO)

American Association of State Highway & Transportation Officials, *M170/M170M, Standard Specification for Reinforced Concrete Culvert, Storm Drain, and Sewer Pipe*, Washington, DC.

American Association of State Highway & Transportation Officials (AASHTO)

American Association of State Highway & Transportation Officials, *M190, Standard Specification for Bituminous*

Coated Corrugated Metal Culvert Pipe and Pipe Aches, Washington, DC.

American Association of State Highway & Transportation Officials (AASHTO)

American Association of State Highway & Transportation Officials, *M196/M196M, Standard Specification for Corrugated Aluminum Pipe for Sewers and Drains*, Washington, DC.

American Association of State Highway & Transportation Officials (AASHTO)

American Association of State Highway & Transportation Officials, *M206/M206M, Standard Specification for Reinforced Concrete Arch Culvert Storm Drain and Sewer Pipe*, Washington, DC.

American Association of State Highway & Transportation Officials (AASHTO)

American Association of State Highway & Transportation Officials, *M207/M207M, Standard Specification for Reinforced Concrete Elliptical Culvert, Storm Drain and Sewer Pipe*, Washington, DC.

American Association of State Highway & Transportation Officials (AASHTO)

American Association of State Highway & Transportation Officials, *M218, Standard Specification for Steel Sheet, Zinc-Coated (Galvanized) for Corrugated Steel Pipe*, Washington, DC.

American Association of State Highway & Transportation Officials (AASHTO)

American Association of State Highway & Transportation Officials, *M242/M242M, Standard Specification for Reinforced Concrete D-Load Culvert, Storm Drain, and Sewer Pipe*, Washington, DC.

American Association of State Highway & Transportation Officials (AASHTO)

American Association of State Highway & Transportation Officials, *M245/M245M, Interim Specification for Corrugated Steel Pipe, Polymer Precoated for Sewers and Drains*, Washington, DC.

American Association of State Highway & Transportation Officials (AASHTO)

American Association of State Highway & Transportation Officials, *M246/M246M, Standard specifications for Steel Sheet, Metallic-Coated and Polymer Precoated for Corrugated Steel Pipe*, Washington, DC.

American Association of State Highway & Transportation Officials (AASHTO)

American Association of State Highway & Transportation Officials, *M259/M259M, Standard Specification for Precast Reinforced Concrete Box Sections for Culverts, Storm Drains, and Sewers*, Washington, DC.

American Association of State Highway & Transportation Officials (AASHTO)

American Association of State Highway & Transportation Officials, *M273/M273M, Standard Specification for Precast Reinforced Concrete Box Sections for Culverts, Storm Drains, and Sewers with less than 2 ft (0.6 m) of Cover Subjected to Highway Loadings*, Washington, DC.

American Association of State Highway & Transportation Officials (AASHTO)

American Association of State Highway & Transportation Officials, *M274, Steel Sheet, Aluminum-Coated (Type 2) for Corrugated Steel Pipe*, Washington, DC.

American Association of State Highway & Transportation Officials (AASHTO)

American Association of State Highway & Transportation Officials, *M278/M278M, Standard Specification for Class PS 50 Polyvinyl Chloride (PVC) Pipe*, Washington, DC.

American Association of State Highway & Transportation Officials (AASHTO)

American Association of State Highway & Transportation Officials, *M294, Standard Specification for Corrugated Polyethylene Pipe 12 in. to 36 in. Diameter*, Washington, DC.

American Association of State Highway & Transportation Officials (AASHTO)

American Association of State Highway & Transportation Officials, *M304, Poly (Vinyl Chloride) (PVC) Profile Wall Drain Pipe and Fittings Based on Controlled Inside Diameter*, Washington, DC.

American Association of State Highway & Transportation Officials (AASHTO)

American Association of State Highway & Transportation Officials, *T99, Standard Method of Test for the Moisture-Density Relations of Soils Using a 5.5 lb (2.5 kg) Rammer and a 12 in. (305 mm) Drop*, Washington, DC.

American Concrete Institute

American Concrete Institute, *Building Code Requirements for Reinforced Concrete (ACI 318)*, Detroit, MI.

American Concrete Pipe Association 1992

American Concrete Pipe Association. 1992. *Concrete Pipe Design Manual*, Vienna, VA.

American Iron and Steel Institute 1993

American Iron and Steel Institute. 1993. *Handbook of Steel Drainage and Highway Construction Products*, Washington, DC.

American Iron and Steel Institute 1989

American Iron and Steel Institute. 1989. *Welded Steel Pipe--Steel Plate Engineering Data*, Volume 3, Washington, DC.

American Railway Engineering Association (AREA) 1996

American Railway Engineering Association (AREA). 1996. *AREA Manual*, Washington, DC.

American Society for Testing and Materials (ASTM)

American Society for Testing and Materials, *A307, Standard Specification for Carbon Steel Bolts and Studs, 60,000 Psi Tensile Strength*, Philadelphia, PA.

American Society for Testing and Materials (ASTM)

American Society for Testing and Materials, *A619/A619M, Standard Specification for Steel, Sheet, Carbon, Cold-Rolled, Drawing Quality*, Philadelphia, PA.

American Society for Testing and Materials (ASTM)

American Society for Testing and Materials, *A742/A742M, Standard Specification for Steel Sheet, Metallic Coated and Polymer Precoated for Corrugated Steel Pipe*, Philadelphia, PA.

American Society for Testing and Materials (ASTM)

American Society for Testing and Materials, *A746, Standard Specification for Ductile Iron Gravity Sewer Pipe*, Philadelphia, PA.

American Society for Testing and Materials (ASTM)

American Society for Testing and Materials, *A760/A760M, Standard Specification for Corrugated Steel Pipe, Metallic-Coated for Sewers and Drains*, Philadelphia, PA.

American Society for Testing and Materials (ASTM)

American Society for Testing and Materials, *A762/A762M, Standard Specification for Corrugated Steel Pipe, Polymer Precoated for Sewers and Drains*, Philadelphia, PA.

American Society for Testing and Materials (ASTM)

American Society for Testing and Materials, A796/
A796M *Standard Practice for Structural Design of Corrugated Steel Pipe, Pipe-Arches, and Arches for Storm and Sanitary Sewers and Other Buried Applications*, Philadelphia, PA.

American Society for Testing and Materials (ASTM)

American Society for Testing and Materials, A798, *Standard Practice for Installing Factory-Made Corrugated Steel Pipe for Sewers and Other Applications*, Philadelphia, PA.

*

American Society for Testing and Materials (ASTM)

American Society for Testing and Materials, A807, *Standard Practice for Installing Corrugated Steel Structural Plate Pipe for Sewers and Other Applications*, Philadelphia, PA.

*

American Society for Testing and Materials (ASTM)

American Society for Testing and Materials, A849/
A849M, *Standard Specification for Post Applied Coatings, Pavings, and Linings for Corrugated Steel Sewer and Drainage Pipe*, Philadelphia, PA.

American Society for Testing and Materials (ASTM)

American Society for Testing and Materials, A885/
A885M, *Standard Specification for Steel Sheet, Zinc and Aramid Fiber Composite Coated for Corrugated Steel Sewer, Culvert, and Underdrain Pipe*, Philadelphia, PA.

*

American Society for Testing and Materials (ASTM)

American Society for Testing and Materials, A929/
A929M, *Standard Specification for Steel Sheet, Metallic-Coated by the Hot-Dip Process for Corrugated Steel Pipe*, Philadelphia, PA.

American Society for Testing and Materials (ASTM)

American Society for Testing and Materials, B744/
B744M, *Standard Specification for Aluminum Alloy Sheet for Corrugated Aluminum Pipe*, Philadelphia, PA.

American Society for Testing and Materials (ASTM)

American Society for Testing and Materials, B745/
B745M, *Standard Specification for Corrugated Aluminum Pipe for Sewers and Drains*, Philadelphia, PA.

American Society for Testing and Materials (ASTM)

American Society for Testing and Materials, B788, *Standard Practice for Installing Factory-Made Corrugated Aluminum Culverts and Storm Sewer Pipe*, Philadelphia, PA.

American Society for Testing and Materials (ASTM)

American Society for Testing and Materials, B789, *Standard Practice for Installing Corrugated Aluminum Structural Plate Pipe for Culverts and Sewers*, Philadelphia, PA.

American Society for Testing and Materials (ASTM)

American Society for Testing and Materials, B790, *Standard Practice for Structural Design of Corrugated Aluminum Pipe, Pipe-Arches and Arches for Culverts, Storm Sewers, and Buried Conduits*, Philadelphia, PA.

American Society for Testing and Materials (ASTM)

American Society for Testing and Materials, C76/C76M, *Standard Specification for Reinforced Concrete Culvert, Storm Drain, and Sewer Pipe*, Philadelphia, PA.

American Society for Testing and Materials (ASTM)

American Society for Testing and Materials, C78/C78M, *Standard Test Method for Flexural Strength of Concrete (Using Simple Beam with triple-Point Loading)*, Philadelphia, PA.

American Society for Testing and Materials (ASTM)

American Society for Testing and Materials, C361/
C361M, *Standard Specification for Reinforced Concrete Low-Head Pressure Pipe*, Philadelphia, PA.

American Society for Testing and Materials (ASTM)

American Society for Testing and Materials, C443/
C443M, *Standard Specification for Joints for Circular Concrete Sewer and Culvert Pipe Using Rubber Gaskets*, Philadelphia, PA.

American Society for Testing and Materials (ASTM)

American Society for Testing and Materials, C497/
C497M, *Standard Test methods for Concrete Pipe, Manhole Sections, or Tile*, Philadelphia, PA.

*

American Society for Testing and Materials (ASTM)

American Society for Testing and Materials, C506/
C506M, *Standard Specification for Reinforced Concrete Arch Culvert, Storm Drain, and Sewer Pipe*, Philadelphia, PA.

American Society for Testing and Materials (ASTM)

American Society for Testing and Materials, C507/
C507M, *Standard Specification for Reinforced Concrete Elliptical Culvert, Storm Drain, and Sewer Pipe*, Philadelphia, PA.

American Society for Testing and Materials (ASTM)
American Society for Testing and Materials, C655/
C655M, *Standard Specification for Reinforced Concrete
D-Load Culvert, Storm Drain, and Sewer Pipe*, Philadel-
phia, PA.

American Society for Testing and Materials (ASTM)
American Society for Testing and Materials, C789/
C789M, *Standard Specification for Precast Reinforced
Concrete Box Sections for Culverts, Storm Drains, and
Sewers*, Philadelphia, PA.

American Society for Testing and Materials (ASTM)
American Society for Testing and Materials, C850/
C850M, *Standard Specification for Precast Reinforced
Concrete Box Sections for Culverts, Storm Drains, and
Sewers with less than 2 ft (0.6 m) of Cover subjected to
Highway Loadings*, Philadelphia, PA.

American Society for Testing and Materials (ASTM)
American Society for Testing and Materials, C857/
C857M, *Standard Practice for Minimum Structural Design
Loading for Underground Precast Concrete Utility Struc-
tures*, Philadelphia, PA.

American Society for Testing and Materials (ASTM)
American Society for Testing and Materials, C877/
C877M, *Standard Specification for External Sealing Bands
for Noncircular Concrete Sewer, Storm Drain, and Culvert
Pipe*, Philadelphia, PA.

American Society for Testing and Materials (ASTM)
American Society for Testing and Materials, C900, *Stan-
dard Test Method for Pullout Strength of Hardened Con-
crete*, Philadelphia, PA.

American Society for Testing and Materials (ASTM)
American Society for Testing and Materials, C924/
C924M, *Standard Practice for Testing Concrete Pipe
Sewer Lines by Low-Pressure Air Test Method*, Philadel-
phia, PA.

American Society for Testing and Materials (ASTM)
American Society for Testing and Materials, C969/
C969M, *Standard Practice for Infiltration and Exfiltration
Acceptance Testing of Installed Precast Concrete Pipe
Sewer Lines*, Philadelphia, PA.

American Society for Testing and Materials (ASTM)
American Society for Testing and Materials, C1103/
C1103M, *Standard Practice for Joint Acceptance Testing
of Installed Precast Concrete Pipe sewer Lines*, Philadel-
phia, PA.

American Society for Testing and Materials (ASTM)
American Society for Testing and Materials, C1214/
C1214M, *Testing Concrete Pipe Sewerlines by Negative
Air Pressure*, Philadelphia, PA.

American Society for Testing and Materials (ASTM)
American Society for Testing and Materials, D698, *Test
Method for Laboratory Compaction Characteristics of
Soil Using Standard Effort (12,000 ft-lbf/ft³) (600 kN-
m/m³)*, Philadelphia, PA.

American Society for Testing and Materials (ASTM)
American Society for Testing and Materials, D1056,
*Standard Specification for Flexible Cellular Materials -
Sponge or Expanded Rubber*, Philadelphia, PA.

American Society for Testing and Materials (ASTM)
American Society for Testing and Materials, D1754,
*Standard Test Method for Effect of Heat and Air on
Asphaltic Materials*, Philadelphia, PA.

American Society for Testing and Materials (ASTM)
American Society for Testing and Materials, D1784,
*Standard Specification for Rigid Poly(Vinyl) Chloride
(PVC) Compounds and Chlorinated Poly(Vinyl Chloride)
CPVC) Compounds*, Philadelphia, PA.

American Society for Testing and Materials (ASTM)
American Society for Testing and Materials, D2262,
*Standard Test Method for Tearing Strength of Woven
Fabrics by the Tongue (Single Rip) Method (Constant Rate
of Traverse Tensile Testing Machine)*, Philadelphia, PA.

American Society for Testing and Materials (ASTM)
American Society for Testing and Materials, D2321,
*Standard Practice for Underground Installation of Ther-
moplastic Pipe for Sewers and Other Gravity-Flow Appli-
cation*, Philadelphia, PA.

American Society for Testing and Materials (ASTM)
American Society for Testing and Materials, D2412,
*Standard Test Method for Determination of External
Loading Characteristics of Plastic Pipe by Parallel-Plate
Loading*, Philadelphia, PA.

American Society for Testing and Materials (ASTM)
American Society for Testing and Materials, D2487-93,
*Standard Classification of Soils for Engineering Purposes
(Unified Soil Classification System)*, Philadelphia, PA.

*

American Society for Testing and Materials (ASTM)
American Society for Testing and Materials, D2680,
*Standard Specification for Acrylonitrile-
Butadiene-Styrene (ABS) and Poly(Vinyl Chloride) (PVC)
Composite Sewer Piping*, Philadelphia, PA.

American Society for Testing and Materials (ASTM)
American Society for Testing and Materials, D3034,
*Standard Specification for Type PSM Poly(Vinyl Chloride)
(PVC) Sewer Pipe and Fittings*, Philadelphia, PA.

American Society for Testing and Materials (ASTM)
American Society for Testing and Materials, D3212,
*Standard Specification for Joint for Drain and Sewer
Plastic Pipes Using Flexible Elastomeric Seals*, Philadel-
phia, PA.

American Society for Testing and Materials (ASTM)
American Society for Testing and Materials, D3262,
*Standard Specification for 'Fiberglass' (Glass-Fiber-
Reinforced Thermosetting Resin) Sewer Pipe*, Philadel-
phia, PA.

American Society for Testing and Materials (ASTM)
American Society for Testing and Materials, D3350,
*Standard Specification for Polyethylene Plastics Pipe and
Fittings Materials*, Philadelphia, PA.

American Society for Testing and Materials (ASTM)
American Society for Testing and Materials, D3550,
Standard Practice for Ring-Lines Barrel Sampling of Soils,
Philadelphia, PA.

American Society for Testing and Materials (ASTM)
American Society for Testing and Materials, D3839,
*Standard Practice for Underground Installation of 'Fiber-
glass' (Glass Fiber Reinforced Thermosetting Resin) Pipe*,
Philadelphia, PA.

American Society for Testing and Materials (ASTM)
American Society for Testing and Materials, D3919,
*Standard Practice for Measuring Trace Elements in Water
by Graphite Furnace Atomic Absorption Spectrophotome-
try*, Philadelphia, PA.

American Society for Testing and Materials (ASTM)
American Society for Testing and Materials, D4253,
*Standard Test Method for Maximum Index Density and
Unit Weight of Soils Using a Vibratory Table*, Philadelphia,
PA.

American Society for Testing and Materials (ASTM)
American Society for Testing and Materials, D4254,
*Standard Test Method for Minimum Index Density and
Unit Weight of Soils and Calculation of Relative Density*,
Philadelphia, PA.

American Society for Testing and Materials (ASTM)
American Society for Testing and Materials, D4161,
*Standard Specification for 'Fiberglass' (Glass
Fiber-Reinforced Thermosetting Resin) Pipe Joints Using
Flexible Elastomeric Seals*, Philadelphia, PA.

American Society for Testing and Materials (ASTM)
American Society for Testing and Materials, F667, *Large
Diameter Corrugated Polyethylene Tubing and Fittings*,
Philadelphia, PA.

American Society for Testing and Materials (ASTM)
American Society for Testing and Materials, F679,
*Standard Specification for Poly(Vinyl Chloride) (PVC)
Large-Diameter Plastic Gravity Sewer Pipe and Fittings*,
Philadelphia, PA.

American Society for Testing and Materials (ASTM)
American Society for Testing and Materials, F714,
*Standard Specification for Polyethylene (PE) Plastic Pipe
(SDR-PR) Based on Outside Diameter*, Philadelphia, PA.

American Society for Testing and Materials (ASTM)
American Society for Testing and Materials, F794,
*Standard Specification for Poly(Vinyl Chloride) (PVC)
Profile Gravity Sewer Pipe and Fittings Based on
Controlled Inside Diameter*, Philadelphia, PA.

American Society for Testing and Materials (ASTM)
American Society for Testing and Materials, F894,
*Standard Specification for Polyethylene (PE) Large
Diameter Profile Wall Sewer and Drain Pipe*, Philadelphia,
PA.

American Society for Testing and Materials (ASTM)
American Society for Testing and Materials, F949,
*Standard Specification for Poly(Vinyl Chloride) (PVC)
Corrugate Sewer Pipe with a Smooth Interior and Fittings*,
Philadelphia, PA.

American Water Works Association 1985
American Water Works Association. 1985. *AWWA M11,
Steel Pipe--A Guide for Design and Installation*, Denver,
CO.

*

American Water Works Association 1989

American Water Works Association. 1989. AWWA C 300, *Standard for Reinforced Concrete Pressure Pipe, Steel Cylinder Type, for Water and Other Liquids*, Denver, CO.

American Water Works Association 1992

American Water Works Association. 1992. AWWA C 301, *Standard for Prestressed Concrete Pressure Pipe, Steel Cylinder Type, for Water and Other Liquids*, Denver, CO.

American Water Works Association 1987

American Water Works Association. 1987. AWWA C 302, *Standard for Reinforced Concrete Pressure Pipe, Noncylinder Type, for Water and Other Liquids*, Denver, CO.

American Water Works Association 1992

American Water Works Association. 1992. AWWA C 304, *Design of Prestressed Concrete Cylinder Pipe*, Denver, CO.

American Water Works Association

American Water Works Association. AWWA C 950, *Standard for Glass Fiber Reinforced Thermosetting Resin Pressure Pipe*, Denver, CO.

American Water Works Association

American Water Works Association, C110/A21.10, *American National Standard for Ductile-Iron and Grey-Iron Fittings 3 in. through 48 in. (75 mm through 1200 mm), for Water and Other Liquids*, Denver, CO, 80235

American Water Works Association

American Water Works Association, C115/A21.15, *American National Standard for Flanged Ductile-Iron Pipe with Threaded Flanges*, Denver, CO, 80235

American Water Works Association

American Water Works Association, C150/A21.50, *American National Standard for the Thickness Design of Ductile Iron Pipe*, Denver, CO.

A-2. Related Publications

EM 1110-2-2105

Design of Hydraulic Steel Structures

EM 1110-2-3104

Structural and Architectural Design of Pump Stations

Abbett 1956

Abbett, Robert W., ed. 1956. *American Civil Engineering Practice*, Vol II, Wiley, New York, NY, pp 18-64 and 19-08.

American Concrete Pipe Association 1988

American Concrete Pipe Association. 1988. *Concrete Pipe Handbook*, Vienna, VA.

American Concrete Pipe Association 1993

American Concrete Pipe Association. 1993. *Concrete Technology Handbook*, Vienna, VA.

American Society of Civil Engineers (ASCE) 1975

American Society for Civil Engineers (ASCE). 1975. *Pipeline Design for Hydrocarbon Gases and Liquids*, New York, NY.

American Society of Civil Engineers (ASCE) 1984

American Society for Civil Engineers (ASCE). 1984. *Pipeline Materials and Design*, New York, NY.

American Society of Civil Engineers (ASCE) 1990

American Society for Civil Engineers (ASCE). 1990. *Pipeline Design and Installation*, New York, NY.

American Society of Civil Engineers (ASCE) 1992

American Society for Civil Engineers (ASCE). 1992. *Standard Practice for Direct Design of Buried Concrete Pipe Using Standard Installations*, New York, NY.

American Society of Civil Engineers (ASCE) 1993

American Society for Civil Engineers (ASCE). 1993. *Steel Penstocks, ASCE Manual Report on Engineering Practice*, No. 79, New York, NY.

Civil Engineering Research Foundation 1992

Civil Engineering Research Foundation. 1992. "Current State of Life Cycle Design for Local Protection Structures, A Literature Search," Washington, DC.

Howard 1977

Howard, Amster K. 1977. Modulus of Soil Reaction (E') Values for Buried Flexible Pipe, *Journal of the Geotechnical Engineering Division*, American Society of Civil Engineers, Vol 103(GT), Proceedings Paper 12700.

Krynine 1938

Krynine, D. P. 1938. Pressures Beneath a Spread Foundation, *Transactions*, American Society of Civil Engineers (ASCE), New York, NY.

*

Leonards 1962

Leonards, G. A., ed. 1962. *Foundation Engineering*, McGraw-Hill, New York, NY.

Metcalf and Eddy 1928

Metcalf, L. and Eddy, H. P. 1928. *American Sewerage Practice*, Vol I, Second Edition, McGraw-Hill, New York, NY.

National Utility Contractors Association

National Utility Contractors Association. *Horizontal Earth Boring and Pipe Jacking Manual No. 2*, Arlington, VA.

Newmark 1942

Newmark, Nathan M. 1942. *Influence Charts for Computation of Stresses in Elastic Foundations*. University of Illinois Bulletin Series, No. 338, Urbana, IL.

Portland Cement Association 1975

Portland Cement Association. 1975. *Concrete Culverts and Conduits*, Skokie, IL.

Roark 1989

Roark, R. J. 1989. *Formulas for Stress and Strain*, McGraw-Hill, New York, NY.

Rowe 1957

Rowe, R. R. 1957. Rigid Culverts Under High Overfills, *Transactions*, American Society of Civil Engineers (ASCE), New York, NY.

Spangler 1948

Spangler, M. G. 1948. Underground Conduits--An Appraisal of Modern Research, *Transactions*, American Society of Civil Engineers (ASCE), New York, NY, p 316.

Szechy 1973

Szechy, K. 1973. *The Art of Tunneling*, Hungarian Academy of Sciences, Budapest, Hungary.

Water Pollution Control Federation 1974

Water Pollution Control Federation. 1974. *Design and Construction of Sanitary and Storm Sewers, Manual of Practice*, No. 9. (American Society of Civil Engineers (ASCE) *Manual of Engineering Practice*, No. 37.), New York, NY.

*

Appendix B Design Examples

Design examples for conduits, culverts, and pipes are presented in this appendix. Each equation in this manual is used in the order presented in its chapter. Once a variable is defined, that value is used throughout the remaining calculations. The design method for corrugated

metal pipe from ASTM A 796 is included for Chapter 4. This method also applies to corrugated aluminum pipe using the ASTM B 790 method of design.

At the end of this appendix is a demonstration of a finite element method computer code used to analyze concrete rectangular and oblong shapes.

Chapter 2: Cast-in-Place Conduits for Dams

Prism Loads

Unit Weight of Soil, Water, and Saturated Soil

$$\gamma_s = 21,210 \text{ N/m}^3 \text{ (135 pcf) - Saturated soil}$$

$$\gamma_d = 18,850 \text{ N/m}^3 \text{ (120 pcf) - Dry soil}$$

$$\gamma_w = 9,800 \text{ N/m}^3 \text{ (62.5 pcf) - Water}$$

Height of Soil, Water and Saturated Soil above the Crown of the Conduit.

$$H_d = 2.44 \text{ m (8 ft) - Dry soil column}$$

$$H_w = 15.24 \text{ m (50 ft) - Water column}$$

$$H_s = 6.10 \text{ m (20 ft) - Saturated column}$$

Vertical Pressures

Vertical pressures for the given soil condition; dry soil, dry and saturated soil, or reservoir condition (saturated soil under water).

$$W_{w1} = \gamma_d \cdot H_d \quad \text{N/m}^2 \text{ (psf)} \quad (2-1) \text{ Dry}$$

or

$$W_{w2} = \gamma_d \cdot H_d + \gamma_s \cdot H_s \quad \text{N/m}^2 \text{ (psf)} \quad (2-1) \text{ Dry and saturated}$$

or

$$W_{w3} = \gamma_w \cdot H_w + (\gamma_s - \gamma_w) \cdot H_s \quad \text{N/m}^2 \text{ (psf)} \quad (2-1) \text{ Reservoir}$$

$$W_{w1} = 45,994 \text{ N/m}^2 \text{ (960 psf)}$$

$$W_{w2} = 1,753,754 \text{ N/m}^2 \text{ (3,660 psf)}$$

$$W_{w3} = 218,953 \text{ N/m}^2 \text{ (4,572 psf)}$$

Internal Water Pressure

$$H_G = 36.6 \text{ m (120 ft) - Hydraulic gradient}$$

$r + 1.22 \text{ m (4 ft)}$ - Internal radius of conduit (+ or -) depending on the position of interest - top or bottom of the conduit

$$w_i = \gamma_w \cdot (H_g + r) \text{ N/m}^2 \text{ (psf)}$$

$$w_i = 370,636 \text{ N/m}^2 \text{ (7,738 psf)}$$

Concentrated Live Loads

Vertical Pressure

$$P = 44,480 \text{ N (10,000 lb)}$$

$$y = 0.305 \text{ m (1 ft) - Y - Cartesian coordinate}$$

$$z = 0.610 \text{ m (2 ft) - Z - Cartesian coordinate}$$

$$x = 0.915 \text{ m (3 ft) - X - Cartesian coordinate}$$

$$R = \sqrt{x^2 + z^2 + y^2} \text{ m (ft) - Radial distance from point load}$$

$$R = 1.141 \text{ m (3.742 ft)}$$

$$W_c = \frac{3 \cdot P \cdot z^3}{2 \cdot \pi \cdot R^5} \text{ N/m}^2 \text{ (psf) - Vertical pressure from a concentrated load} \quad (2-3)$$

$$w_c = 2,490 \text{ N/m}^2 \text{ (52 psf)}$$

Horizontal Pressure

$$r = 0.610 \text{ m (2 ft) - Surface radius from point load}$$

$$\mu = 0.3 \text{ Poisson's ratio: 0.5 for saturated cohesive soils, 0.2 to 0.3 for other soils}$$

$$p_c = \frac{P}{2 \cdot \pi} \cdot \left[\frac{3 \cdot r^2 \cdot z}{R^5} - \frac{(1 - 2 \cdot \mu)}{(R + z) \cdot R} \right] \text{ Nsm (psf)} \quad (2-4)$$

$$p_c = 1,074 \text{ N/m}^2 \text{ (23 psf)}$$

Trench Backfill Loads

Trench with No Superimposed Fill, Condition I

Vertical Trench Load	Values for $K_{\mu'}$ and g are		
$K_{\mu'} = 0.15$	Granular w/o cohesion $K_{\mu'} = 0.1924$, $g = 15,700 \text{ N/m}^3$ (100 pcf)		
$H = 2.44 \text{ m (8 ft)}$	Sand and gravel	18,850 (120)	0.165
	Saturated topsoil	17,280 (110)	150
	Ordinary clay	15,710 (100)	0.130
$B_d = 1.52 \text{ m (5 ft)}$	Saturated clay	20,420 (130)	0.110
	Maximum design load	22,000 (140)	0.110

$$C_d = \frac{1 - \exp\left[-2 \cdot K_{\mu'} \cdot \left(\frac{H}{B_d}\right)\right]}{2 \cdot K_{\mu'}} \quad \text{Trench coefficient} \quad (2-7)$$

$c_d = 1.274$ Dimensionless

$B_c = 1.22$ m (4 ft)

$$W_{e1} = C_d \cdot \gamma_d \cdot B_d^2 \quad \text{N/m (lbf/ft)} \quad (2-5)$$

or

$$W_{e2} = \gamma_d \cdot B_c \cdot H \quad \text{N/m (lbf/ft)} \quad (2-6)$$

$W_{e1} = 55,483$ N/m (3,812 lbf/ft)

$W_{e2} = 56,113$ N/m (3,840 lbf/ft)

Horizontal Trench Pressure

$\phi = 30^\circ =$ Internal friction angle in degrees

$H = 6.1$ m (20 ft)

$\gamma_d = 18,850$ N/m³ (120 pcf) for dry soil

$$P_{e2} = \gamma_d \cdot H \cdot \left[\tan^2 \left(45^\circ - \frac{\phi}{2} \right) \right]^2 \quad \text{N/m}^2 \text{ (psf)} \quad (2-8)$$

$p_{e2} = 38,828$ N/m² (800 psf)

Trench with Superimposed Fill, Condition II

Vertical Trench Load

$H_f = 3$ m (10 ft) - Height of superimposed fill above the top of the trench

$H_h = 1.5$ m (5 ft) - Height of effective fill in trench

$H_p = 1.2$ m (4 ft) - Height of projected conduit above the natural ground

$$W_{w3} = C_d \cdot \gamma_d \cdot B_d^2 + \left(\frac{H_f}{H_c + H_p} \right) \cdot \left(1.5 \cdot \gamma_d \cdot B_c \cdot H_h - C_d \cdot \gamma_d \cdot B_d^2 \right) \quad \text{N/m (lbf/ft)} \quad (2-9)$$

or

$$W_{e4} = \gamma_d \cdot B_c \cdot H_h + \left(\frac{H_f}{H_c + H_p} \right) \cdot \left(1.5 \cdot \gamma_d \cdot B_c \cdot H_h - \gamma_d \cdot B_c \cdot H_h \right) \quad \text{N/m (lbf/ft)} \quad (2-10)$$

$$W_{e3} = 53,946 \text{ N/m (3,724 lbf/ft)}$$

$$W_{e4} = 41,584 \text{ N/m (2,900 lbf/ft)}$$

Horizontal Trench Pressure

$$P_{e3} = \gamma \cdot H_h \cdot \left[\tan^2 \left(45 \cdot \text{deg} - \frac{\phi}{2} \right) \right] + \left(\frac{H_f}{H_c + H_p} \right) \cdot \left\{ 0.5 \cdot \gamma \cdot H_h - \gamma \cdot H_h \cdot \left[\tan^2 \left(45 \cdot \text{deg} - \frac{\phi}{2} \right) \right] \right\} \quad (2-11)$$

$$P_{e3} = 11,362 \text{ N/m (242 lbf/ft)}$$

Embankment Condition III

Vertical Loads in N/m (lbf/ft) using $\gamma_d = 18,850 \text{ N/m}^3$ (120 pcf) dry soil:

$$\text{Case 1: } W_{e5} = 1.5 \cdot \gamma_d \cdot B_c \cdot H_c \quad (2-12)$$

$$\text{Case 2: } W_{e6} = \gamma_d \cdot B_c \cdot H_c \quad (2-13)$$

Vertical Loads in N/m^2 (psf)

$$\text{Case 1: } W_{e7} = 1.5 \cdot \gamma_d \cdot H_c \quad (2-14)$$

$$\text{Case 2: } W_{e8} = \gamma_d \cdot H_c \quad (2-15)$$

$$W_{e5} = 210,423 \text{ N/m (14,400 lbf/ft)}$$

$$W_{e6} = 140,282 \text{ N/m (9,600 lbf/ft)}$$

$$W_{e7} = 172,478 \text{ N/m}^2 \text{ (3,600 psf)}$$

$$W_{e8} = 114,985 \text{ N/m}^2 \text{ (2,400 psf)}$$

Horizontal Loads in N/m^2 (psf)

$$\text{Case 1: } p_{e4} = 0.5 \cdot \gamma_d \cdot H_c \text{ N/m}^2 \text{ (psf)} \quad (2-16)$$

$$\text{Case 2: } p_{e5} = \gamma_d \cdot H_c \text{ N/m}^2 \text{ (1,200 psf)} \quad (2-17)$$

$$p_{e4} = 57,493 \text{ N/m}^2 \text{ (1,200 psf)}$$

$$p_{e5} = 114,985 \text{ N/m}^2 \text{ (2,400 psf)}$$

Notes on Loading Conditions for Embankments

Case 1: $p_e/w_e = 0.3$ and $k_a = 0.50$

Case 2: $p_e/w_e = 1.00$ and $k_a = 1.00$

Chapter 3: Circular Precast Concrete Pipe for Small Dams and Major Levees

D-Load Analysis

Load Factor for Trench Condition

Bedding Type	Load Factor
Ordinary	1.5
First Class	1.9
Concrete Cradle	2.5

Load Factors for Embankment Condition

Projection Ratio ρ	Concrete Cradle X_a	Other Projection Bedding X_a
0.0	0.150	0.000
0.3	0.743	0.217
0.5	0.856	0.423
0.7	0.811	0.594
0.9	0.678	0.655
1.0	0.638	0.638

Type of Bedding X_p	
Impermissible	1.310
Ordinary	0.840
First Class	0.707
Concrete Cradle	0.505

$$X_a = 0.811$$

$$X_p = 0.505$$

$$B_f = \frac{1.431}{X_p - \left(\frac{X_a}{3}\right)} \quad (3-1)$$

ASTM C76 Class and $D_{0.01}$

	Class	$D_{0.01}$
$B_f = 6.098$		
$W_1 = 145,940 \text{ N/m (10,000 plf)}$	I	40 (800)
$W_e = 175,130 \text{ N/m (12,000 plf)}$	II	50 (1,000)
$H_f = 1.3 \text{ Factor of Safety}$	III	65 (1,350)
	IV	100 (2,000)
$S_i = 1,200 \text{ mm (4 ft)}$	V	140 (3,000)

*

*

$$D_{\text{reqd}} = \frac{W_{\omega}}{B_{\omega}} \cdot \frac{H_{\omega}}{S_x} = \frac{W_{\omega} (H_{\omega})}{B_{\omega} (S_x)} \quad (3-2)$$

*

$D_{0.01} = 57 \text{ N/m/mm (1,172 plf/ft) ASTM C76M Class III}$

Chapter 4: Corrugated Metal Pipe for Rural Levees

Design in accordance with ASTM A 796 or ASTM B 790

Earth Load (EL)

$$H = 3 \text{ m (10 ft)}$$

$$w = 18,850 \text{ N/m}^2 \text{ (120 pcf)}$$

$$EL = H \cdot w \text{ N/m}^2 \text{ (psf)}$$

$$EL = 56,550 \text{ N/m}^2 \text{ (1,220 psf)}$$

Live Load (LL)

Live Loads Under Highways and Railroads

<u>Height of Cover, m (ft)</u>	<u>Highway, N/m² (psf)</u>	<u>Railroad, N/m² (psf)</u>
0.3 (1)	86,180 (1,800)	
0.6 (2)	38,300 (800)	181,940 (3,800)
0.9 (3)	28,730 (600)	
1.2 (4)	19,150 (400)	
1.5 (5)	11,970 (250)	114,910 (2,400)
1.8 (6)	9,580 (200)	
2.1 (7)	8,380 (175)	
2.4 (8)	4,790 (100)	76,610 (1,600)
3.0 (10)		52,670 (1,100)
3.7 (12)		38,300 (800)
4.6 (15)		28,730 (600)
6.1 (20)		14,360 (300)
9.1 (30)		4,790 (100)

$LL = 38,200 \text{ N/m}^2 \text{ (800 psf)}$ - Live load includes impact

$$P = EL + LL \text{ N/m}^2 \text{ (psf)}$$

$P = 94,850 \text{ N/m}^2 \text{ (2,000 psf)}$ - Total load on conduit

Required Wall Area

$S = 1.2$ m (4 ft) - Span of conduit

$$T = \frac{(P \cdot S)}{2} \text{ Thrust per length of conduit}$$

$T = 56,910$ N/m (4,000 lbf/ft) - Thrust per length of conduit

$SF = 2$ Factor of Safety

$f_y = 227,530,000$ N/m² (33,000 psi) - Steel yield strength

$$A = \frac{T \cdot SF}{f_y} \cdot 1000 \text{ mm}^2/\text{mm} \text{ (in.}^2/\text{ft) Required area of wall}$$

$A = 0.5002$ mm²/mm (0.2424 in.²/ft) - Required area of wall

Critical Buckling Stress

$k = 0.22$ Soil stiffness factor for granular side fill material

$E = 2 \cdot 10^{11}$ N/m² (29,000,000 psi) Modulus of elasticity of steel

$f_u = 3.10 \cdot 10^8$ N/m² (45,000 psi) Ultimate strength of metal

$r = 4.3713$ mm (0.1721 in.) Radius of gyration (from ASTM)

$s = 1,220$ mm (48 in.) Conduit span

$$f_{c1} = f_u - \frac{f_u^2}{48 \cdot E} \cdot \left(\frac{k \cdot s}{r} \right)^2 \text{ Buckling strength of conduit wall}$$

or

$$f_{c2} = \frac{12 \cdot E}{\left(\frac{K \cdot s}{r} \right)^2}$$

$$f_c = \text{if } \left(s < \frac{r}{k} \cdot \sqrt{\frac{24 \cdot E}{f_u} \cdot f_{c1} \cdot f_{c2}} \right)$$

$f_c = 2.72 \cdot 10^8$ N/m² (39,523 psi) - This value is greater than the yield strength of the material; therefore, the wall area calculated is adequate. If this value were less than the yield strength then the wall area would need to be recalculated with the lesser value.

Required Seam Strength

$SF_s = 3$ Safety factor for seams

$SS = T \cdot SF_s$ Required seam strength in N/m (lbf/ft)

$SS = 170,730 \text{ N/m}^2$ (12,000 lbf/ft) - Check values with tables in ASTM A 796 or ASTM B 790

Handling and Installation Strength

$I = 39,198 \text{ mm}^4/\text{mm}$ (2.392 in.⁴/ft) - Moment in Inertia of the section selected from the ASTM

$$FF = \frac{S^2}{E \cdot I} \cdot 1,000,000 \text{ mm/N} \quad (FF/10^6 \text{ in./lb})$$

$FF = 0.00019 \text{ mm/N}$ (0.00003 in./lbf) - Flexibility factor shall not exceed the value in the ASTM

Flexibility Factors

	Trench	Embankment
<u>Depth of Corrugation, mm (in.)</u>	<u>FF, mm/N (in./lb)</u>	<u>FF, mm/N (in./lb)</u>
6 (1/4)	0.255 (0.043)	0.255 (0.043)
13 (1/2)	0.343 (0.060)	0.255 (0.043)
25 (1)	0.343 (0.060)	0.188 (0.033)
50 (2 (round pipe))	0.114 (0.020)	0.114 (0.020)
50 (2 (arch))		0.171 (0.030)
140 (5-1/2 (round))	0.114 (0.020)	0.114 (0.020)
140 (5-1/2 (arch))		0.171 (0.030)

Minimum Cover Design

$d = 13 \text{ mm}$ (1/2 in.) - Depth of corrugations

$A_L = 142,340 \text{ N}$ (32,000 lb) - Maximum highway axle load

Highway Loadings

<u>Class</u>	<u>Maximum Axle Load, N (lb)</u>
H 20	142,340 (32,000)
HS 20	142,340 (32,000)
H 15	106,760 (24,000)
HS 15	106,760 (24,000)

$$H_{\min} = \text{if} \left[0.23 < \sqrt{\frac{A_L \cdot d}{E \cdot I}} \cdot \frac{S}{8} \text{ if} \left(0.45 > \sqrt{\frac{A_L \cdot d}{E \cdot I}} \cdot \frac{S}{4}, 0.55 \cdot S \cdot \sqrt{\frac{A_L \cdot d}{E \cdot I}} \right) \right]$$

$H_{\min} = 0.3 \text{ m (1 ft)}$ - minimum cover for highway loads and is never less than 0.3 m (1 ft)

Check the requirements for railroad and aircraft loads.

Pipe-Arch Bearing Design

Maximum height of fill over arch pipe assuming 191,520 N/m² (2 tsf) bearing capacity for the soil

$r_c = 0.46 \text{ m (1.5 ft)}$ - corner radius of pipe-arch

$$H_{\max} = \frac{66.7 \cdot r_c}{S} \cdot 0.3048 \text{ m (} H_{\max}/0.3048 = \text{ft) Maximum cover}$$

$H_{\max} = 7.79 \text{ m (25 ft)}$

Chapter 5: Culverts

Use the same design procedure as developed in Chapter 3 for precast pipe. Use the bedding load factors as defined in American Concrete Pipe Association Concrete Pipe Design Manual (1992).

Circular Concrete Culvert, Class B Bedding, Embankment Condition

$$B_f = \frac{C_A}{C_N - xq} \quad (5-1)$$

$$C_A = 1.431$$

$$C_N = 0.707$$

$$x = 0.594$$

$$A = 0.33$$

$$P = 0.7$$

$$C_c = 3$$

$$H = 8$$

$$B_c = 4 \text{ ft}$$

$$E = 0.50$$

$$q = \frac{AP}{C_c} \left(\frac{H}{B_c} + EP \right) \leq 0.33$$

$$q = \frac{0.33(0.7)}{3} (2 + 0.5(0.7)) = 0.181 \geq 0.33 \quad (5-2)$$

Bedding factor B_f

$$B_f = \frac{1.431}{[0.707 - 0.594 (0.181)]} = 2.387$$

$D_{0.01}$ Calculation

$$D_{0.01} = \frac{W_T H_f}{S_i B_f}$$

$$S_i = B_c = 4 \text{ ft}$$

$$H_f = 1.0$$

$$B_f = 2.387$$

$$W_T = 1.5 \gamma B_c H_h; \quad \gamma = 120 \text{ pcf}$$

$$H_h = 8 + \frac{4}{2} = 10 \text{ ft}$$

$$W_T = 1.5(120)(4)(10) = 7200 \text{ lbf/ft}$$

$$D_{0.01} = \frac{7200 (1)}{4 (2.387)} = 754 \frac{\text{lb}}{\text{ft/ft}}$$

Use Class I, C76 Pipe

Chapter 6: Plastic Pipe for Other Applications

Pipe Stiffness

$D = 0.250$ m (10 in.) - Pipe diameter

$R = \frac{D}{2}$ $R = 0.125$ m (5 in.) - Pipe radius

$t = 8$ mm (0.134 5 in.) - Wall thickness

$E_p = 3.03 \cdot 10^9$ N/m² (440,000 psi) - Initial modulus of elasticity (plastic)

$I = \frac{t^3}{12} \cdot 10^{-9}$ m⁴/m (in.⁴/in.) Moment of inertia

$I = 4.27 \cdot 10^{-8}$ m⁴/m (0.0026 in.⁴/in.)

$$FF = \frac{D^2}{E \cdot I} * 1000 < = 0.542 \text{ m/N (95 in./lb)} \quad (6-1)$$

$FF = 0.4834$ m/N (85 in.lb)

$$PS = \frac{E \cdot I}{0.149 \cdot R^3} > = 98,946/D \text{ N/m/m (565/D lb/in./in.)} \quad (6-2)$$

$$PS = 444,237 \geq \frac{98,946}{D} = 395,784 \text{ OK}$$

Deflection

$D_L = 2.5$ Deflection lag factor for long-term prediction

$K = 0.11$ Bedding constant

$E' = 6.89 \cdot 10^6$ N/m² (1,000 psi) - Soil modulus

$P = 69,000$ N/m² (10 psi) - Service pressure at the crown of the pipe

$$\frac{\Delta Y}{D} = \frac{D_L \cdot K \cdot P}{0.149 \cdot (PS) + 0.061 \cdot (E')} \cdot 100 \text{ percent} \quad (6-3)$$

$$\frac{\Delta Y}{D} = 3.90\% \text{ - Pipe deflection}$$

Wall Stress (Crushing)

$P_{ST} = 68,950 \text{ N/m}^2$ (1,440 psf) - Short-term pressure at the crown of the conduit

$P_{LT} = 68,950 \text{ N/m}^2$ (1,440 psf) - Long-term pressure at the crown of the conduit

$f_i = 3.03 \cdot 10^9 \text{ N/m}^2$ (440,000 psi) Initial tensile strength of the pipe material

$f_{50} = 1.09 \cdot 10^9 \text{ N/m}^2$ (158,400 psi) - 50-year tensile strength of the pipe material

$D = 0.3 \text{ m}$ (1 ft) - Diameter of pipe

$$T_{ST} = D \cdot \frac{P_{ST}}{2} = 10,343 \text{ N/m (720 lbf/ft)} \quad \text{- Short-term wall thrust} \quad (6-4)$$

$$T_{LT} = D \cdot \frac{P_{LT}}{2} = 10,343 \text{ N/m (720 lbf/ft)} \quad \text{- Long-term wall thrust} \quad (6-5)$$

$$A \geq 2 \cdot \left(\frac{T_{ST}}{f_i} + \frac{T_{LT}}{f_{50}} \right) \cdot 10^6 \quad A = 25.8 \text{ mm}^2/\text{m (0.0124 in.}^2/\text{ft)} \quad \text{- Wall area} \quad (6-6)$$

Ring Buckling

$H = 3 \text{ m}$ (10 ft) - Height of soil above the crown of the pipe

$H_w = 6 \text{ m}$ (20 ft) - Height of water above the crown of the pipe

$R = 0.3 \text{ m}$ (12 in.) - Mean radius

$$B = 1 - 0.33 \cdot \frac{h_w}{h} \quad \text{Buoyancy factor } B = 0.34$$

$E = 9.65 \cdot 10^8 \text{ N/m}^2$ (140,000 psi) - 50-year Modulus of elasticity

$M_s = 11.72 \cdot 10^6 \text{ N/m}^2$ (1,700 psi) - Soil modulus

$A = 3,050 \text{ mm}^2/\text{m}$ (1.44 in.²/ft) - Wall area

$I = 42,610 \text{ mm}^4/\text{m}$ (0.0026 in.⁴/in.) - Moment of inertia of the wall section

$$f_{cr} = \frac{0.77 \cdot R}{A} \cdot \sqrt{\frac{B \cdot M_s \cdot E \cdot I}{0.149 \cdot R^3}} \quad \text{N/m}^2 \quad (fa* 12 \text{ (psi)}) \quad \text{- Wall buckling stress} \quad (6-7)$$

31 Oct 97

$$f_{cr} = \frac{f_a FS}{2} = 2 f_{cr} = 7.6424 \cdot 10^6 \text{ N/m}^2 \text{ (1,096 psi)}$$

Hydrostatic Buckling

$\nu = 0.39$ Poisson's ration

$K = 1.5 (10)^{-12}$ SI, 216 non-SI

$$P_{cr} = C \left(\frac{KEI}{(1 - \nu^2)R^3} \right) \cdot 0.7 \text{ N/m}^2 \text{ (psf)} - \text{Buckling stress} \quad (6-8)$$

$C = \text{Ovality} = 0.7$ for 4 percent deflection

$P_{cr} = 1,886 \text{ N/m}^2 \text{ (37.3 psf)}$ - Field stress or radial pressure from the water

Wall Strain Cracking

$t_{max} = 6 \text{ mm (0.25 in.)}$ - Thickness of pipe wall

$D = 250 \text{ mm (10 in.)}$ - Pipe diameter

$\frac{\Delta Y}{D} = 3.9\%$ Ratio of pipe deflection to pipe diameter

$$\epsilon_b = \frac{t_{max}}{D} \cdot \left[\frac{0.03 \cdot \frac{\Delta Y}{D}}{1 - \left(0.02 \cdot \frac{\Delta Y}{D} \right)} \right] \text{ mm/mm (in./in.)} - \text{Wall strain} < \text{strain limit}/2 \quad (6-9)$$

$\epsilon_b = 0.003 < 0.05/2 = 0.025$ OK

Chapter 7: Ductile Iron Pipe and Steel Pipe for Other Applications

Earth Load Limited by:

Bending Stress

$$f = 3.31 \cdot 10^8 \text{ N/m}^2 \text{ (48,000 psi) - Design stress}$$

$$t = 6 \text{ mm (0.25 in.) - Wall thickness}$$

$$D = 250 \text{ mm (10 in.) - Pipe diameter}$$

$$E = 165.5 \cdot 10^9 \text{ N/m}^2 \text{ (24,000,000 psi) - Modulus of elasticity}$$

$$E' = 3.45 \cdot 10^6 \text{ N/m}^2 \text{ (500 psi) - Soil modulus DIPRA Type 4 bedding}$$

$$K_b = 0.157 \text{ Bending moment coefficient}$$

$$K_x = 0.096 \text{ Deflection coefficient}$$

$$\Delta x/D = 0.03 \text{ Deflection limit}$$

$$P_v = \frac{f}{3 \left(\frac{D^2}{t^2} - \frac{D}{t} \right) \left[K_b - \frac{K_x}{\left[\frac{8E}{E'} \right]^3 + 0.732} \right]} \quad (7-1)$$

$$P_{v1} = 458,267 \text{ N/m}^2 \text{ (10,279 psf)}$$

Deflection

$$P_v = \left(\frac{\Delta x/D}{12K_x} \right) \left(\frac{8E}{\left(\frac{D}{t_m} - 1 \right)^3} + 0.732 E' \right) \quad (7-2)$$

$$P_{v2} = 578,439 \text{ N/m}^2 \text{ (12,061 psf)}$$

Chapter 8: Pipe Jacking

$B_t = 1.2$ m (4 ft) - Diameter of pipe

$w = 18,850$ N/m³ (120 pcf) - Unit weight of soil

$K_\mu = 0.130$ Soil constant

$H = 15$ m (50 ft) - Height of soil

$c = 4,790$ N/m² (100 psf) - Cohesion

$$C_t = 1 - \frac{\exp\left[-2 \cdot K_{\mu'} \cdot \left(\frac{H}{B_t}\right)\right]}{2 \cdot K_{\mu'}} \quad \text{Load coefficient} \quad (8-2)$$

$C_t = 0.8509$ Load coefficient

$$W_t = C_t \cdot w \cdot B_t^2 - 2 \cdot c \cdot C_t \cdot B_t \quad \text{N/m (lb/ft)} - \text{Earth load on pipe} \quad (8-1)$$

$W_t = 13,314$ N/m (953 lb/ft)

Rectangular Conduit (Trench) - Cast-In-Place

Vertical Pressure

$$W_e = 18.9 (3) = 57.6 \text{ kPa (1,200 psf)}$$

$$P_{e_T} = \frac{57.6}{3} = 19.2 \text{ kPa (400 psf)}$$

$$P_{e_b} = \frac{4.5 \text{ m (19.2)}}{3.0 \text{ m}} = 28.8 \text{ kPa (600 psf)}$$

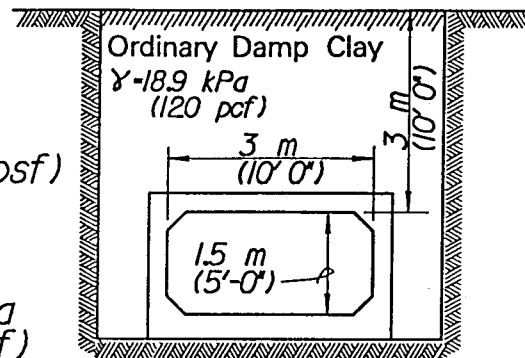

BOX

W_s = Weight of Structure
kN-m (plf)

Next calculate FEM's and distribute to design section.
Use load factors from EM 1110-2-2104.

Other Computer programs that can be used to analyze this shaped culvert include CANDE (Culvert Analysis Design), CORTCUL (Design or Investigation of Orthogonal Culverts)

Standard reinforcement for rectangular sections is included in ASTM C789 and C850.

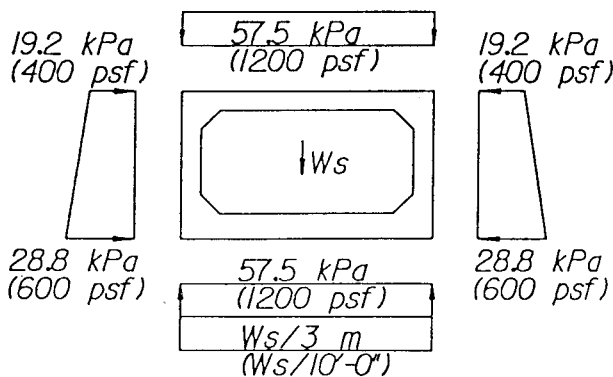

LOADING DIAGRAM

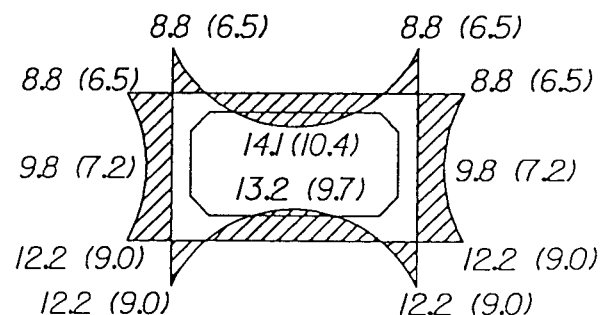

MOMENT DIAGRAM

kN-m
(K-ft)

Oblong Conduit (Trench) - Cast-In-Place

Vertical Pressure

$$W_e = 18.9 (3) = 57.6 \text{ kPa (1,200 psf)}$$

$$P_{e_T} = \frac{57.6}{3} = 19.2 \text{ kPa (400 psf)}$$

$$P_{e_b} = \frac{11.1 \text{ m (19.2)}}{3.0 \text{ m}} = 71.0 \text{ kPa (1500 psf)}$$

$$W_{avg} = \frac{(P_{e_T} + P_{e_b})}{2} = \frac{45.6 \text{ kPa (950 psf)}}{2} \quad (7'-6")$$

W_s = Weight of Structure
kN-m (plf)

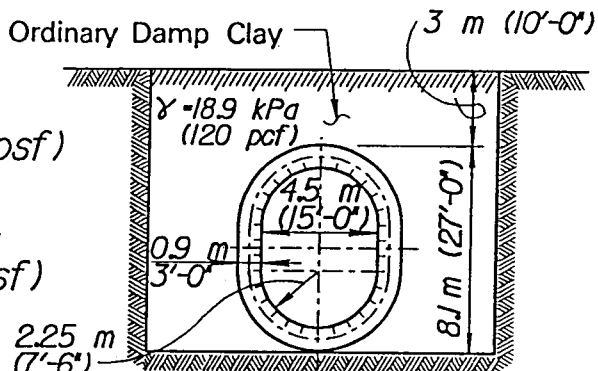

OBLONG PIPE

Moments and shears for this section were calculated using the computer program STAAD III. Other finite element computer programs work as well.

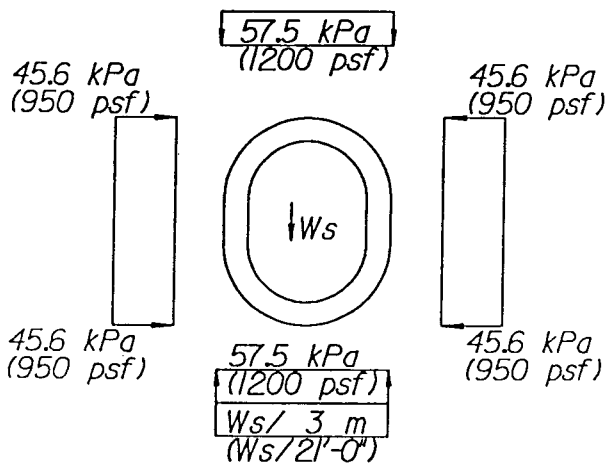

LOADING DIAGRAM

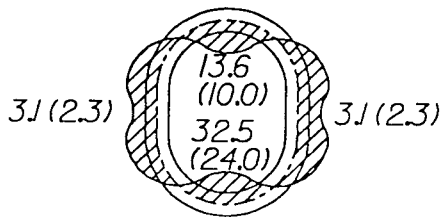

MOMENT DIAGRAM

kN-m
(K-ft)

Appendix C Evaluation and Inspection of Existing Systems

This appendix will be completed when data become available in the future. The outline below presents a list of key features that need to be considered when evaluating and inspecting existing systems.

C-1. Site Inspection

- a. Surface settlement.*
- b. Surface water.*
- c. Dip in pavement.*
- d. Settlement of manholes or control structure.*

C-2. Interior Inspection

- a. Visual inspection.*
- b. Camera inspection.*

- c. Smoke testing.*
- d. Infiltration.*
- e. Exfiltration.*
- f. Piping.*

C-3. Failures

- a. Leaking joints.*
- b. Separated joints.*
- c. Crushed pipe wall.*
- d. Perforated pipe wall.*
- e. Misaligned pipe sections.*
- f. Root penetration of pipe.*
- g. Material deposition.*
- h. Change in loading condition.*

Appendix D Repair of Existing Systems

This appendix will be completed when data become available in the future. The outline below lists some methods to repair existing systems.

D-1. Pipe Replacement

D-2. Slip Lining

D-3. In-Place Fracturing and Replacement

D-4. Concrete Relining

D-5. Plastic Relining and Grouting

D-6. Jacking Pipe

Appendix E Metric Conversion Data Sheet

Quantity	Unit	Symbol
length	meter	m
mass	kilogram	kg
time	second	s
force	newton	$N = \text{kg m/s}^2$
stress	pascal	$\text{Pa} = \text{N/m}^2$
energy	joule	$J = \text{N}\cdot\text{m}$

Metric Conversions

Multiply	By	To Obtain
Area and Volume		
ft^2	0.092 903	m^2
ft^3	0.028 136 847	m^3
gal	0.003 785 412	m^3
in.^2	645.160 000	mm^2
Section Modulus		
in.^3	16 387.064	mm^3
Moment of Inertia		
in.^4	416 231.430	mm^4
Length		
foot (ft)	304.800	millimeters (mm)
inch (in.)	25.400	millimeters (mm)

Multiply	By	To Obtain
Mass		
kg (force/mass)	9.806 650	N
pound-mass (lbm)	0.453 592	kilogram (kg, mass)
Force		
pound-force (lbf)	4.448 222	N
lbf/ft	14.593 903	N/m
Torque		
lb-in.	0.112 985	N-m
lb-ft	1.355 818	N-m
Pressure and Density		
foot of water	2.988 980	kPa
g/cm^3	62.427 900	pcf
g/cm^3	9.806 650	kN/m^3
kg/cm^2	98.066 500	kPa
ksi	6.894 757	MPa, N/mm^2
pcf	16.018 460	kg/m^3
pcf	157.087 616	N/m^3
psf	47.880 260	Pa
psi	6.894 757	kPa