



# ***PDHengineer.com***

**Course Nº HV-8002**

## **Commercial HVAC**

This document is the course text. You may review this material at your leisure before or after you purchase the course. If you have not already purchased the course, you may do so now by returning to the course overview page located at:

<http://www.pdhengineer.com/pages/M-8003.htm>  
(Please be sure to capitalize and use dash as shown above.)

Once the course has been purchased, you can easily return to the course overview, course document and quiz from PDHengineer's My Account menu.

If you have any questions or concerns, remember you can contact us by using the Live Support Chat link located on any of our web pages, by email at [administrator@PDHengineer.com](mailto:administrator@PDHengineer.com) or by telephone toll-free at 1-877-PDHengineer.

Thank you for choosing PDHengineer.com.



17350 State Highway 249 | Suite 140 | Houston, TX 77064

## Course Introduction

Commercial air-conditioning or HVAC (Heating, Ventilation and Air Conditioning) refer to the mechanical systems which heat, cool, filter or dehumidify air in a room or building. HVAC systems control the ambient environment (temperature, humidity, air flow, and air filtering) in homes and commercial buildings and are crucial in maintaining environmental conditions in critical applications such as data centers, medical rooms, computer server rooms, and other cleanroom applications.

1. In cooling mode, excess room heat is absorbed by a special liquid - a refrigerant - sealed within the system. As the refrigerant absorbs the heat from the room it changes into a gas and passes through small, copper tubes to an outdoor unit (condenser) where the heat is released, into the atmosphere. The gas then changes back into a cold liquid, returning to the indoor unit where the air is fanned over it and out into the room. This cycle is automatically repeated to maintain the preset room temperature.  
  
The cooling operation not only cools the air but also removes moisture out of the air. Moisture condenses on the indoor coil like it does on the outside of a glass of ice water on a hot, humid day. As the warm air passes over the coil and is cooled it can't hold the same amount of moisture. The extra moisture is then carried away through the built in drain pan.
2. In heating mode, the cooling cycle is reversed and the system is called a heat pump. A heat pump extracts "free" heat from the outdoor air, even on the coldest days when the temperature may fall as low as -10 degrees Celsius and transfers the heat indoors. Heat pump units therefore avoid the need for a boiler and allow you to cool and heat with the same unit, with savings in costs and energy throughout the year. Another way to heat the space is to use electric or hot water baseboards or radiant panels.

Engineering of an air-conditioning system starts with the selection of design conditions; air temperature and relative humidity are principal factors. Next, calculate the loads on the system (for example heat load arises from equipment, lights, exterior solar, and people). Finally, equipment is selected and sized to perform the indicated functions and to carry the estimated loads. Each space is analyzed separately. A cooling load will exist when the sum of heat released within the space and transmitted to the space is greater than the loss of heat from the space. A heating load occurs when the heat generated within the space is less than the loss of heat from it. Similar considerations apply to moisture.

The rate at which heat is conducted through the building envelope is a function of the temperature difference across the envelope and the thermal resistance of the envelope (R value). Overall R values depend on materials of construction and their thickness along the path of heat flow, and air spaces with or without reflectances and emittances, and are evaluated for walls and roofs exposed to outdoors, and

basements or slab exposed to earth. In some cases, thermal insulations may be added to increase the R value of the envelope.

Solar heat loads are an especially important part of load calculation because they represent a large percentage of heat gain through walls, windows, and roofs, but are very difficult to estimate because solar irradiation is constantly changing.

Humidity as a load on an air-conditioning system is treated by the engineer in terms of its latent heat, that is, the heat required to condense or evaporate the moisture, approximately 1000 Btu/lb of moisture. People at rest or at light work generate about 200 Btu/h. Steaming from kitchen activities and moisture generated as a product of combustion of gas flames, or from all drying processes, must be calculated. As with heat, moisture travels through the space envelope, and its rate of transfer is calculated as a function of the difference in vapor pressure across the space envelope and the permeance of the envelope construction.

Heat pumps and air conditioners are generally sized in tons. Typical sizes for single family residences are between two and five tons. Each refrigeration ton equals to the heat extraction rate of 12,000 Btu per hour. It is important to note that actual capacity is not constant and will change based on outdoor or indoor temperatures. The published capacity rating of air conditioners and heat pumps is based on performance at the ARI standard temperature levels of 95°F outside, 80°F inside.

## **TYPES OF COOLING SYSTEMS**

The most common air-cooling systems are either direct expansion (DX) type or the chilled water type.

### **DIRECT EXPANSION (DX) SYSTEMS**

In DX systems, the air is cooled with direct exchange of heat with refrigerant passing through the tubes of the finned cooling coil. All these systems are comprised of a hermetically sealed or open compressor(s), evaporator (cooling coil fabricated out of copper tubes and aluminum fins), a supply air blower, filter, a condenser and heat rejection propeller fan. These come in two types:

1. **Unitary System** - In a unitary system, the complete cooling system is in one casing. Since all equipment is prepackaged, the installation cost is usually lower, and the performance quality is often higher than field-erected systems. Window air-conditioners, package units are typical examples of unitary DX systems.
  - Room air conditioner (capacity range of 0.5 to 3 TR per unit, suitable for an area of not more than 1000 square feet).
  - Packaged unit integral air-cooled condenser (capacity range of 3 to 50 TR, suitable for a maximum area of 1000 – 10000 square feet).

2. **Split System** - The second DX concept, where the evaporator is separate from the condenser/compressor, is called a split system. These are commonly found in residential and small commercial installations with capacity ranges varying 1 to 50 TR and suitable for an area of 100 – 10000 square feet. The new ductless systems which can be conveniently mounted on the ceiling or wall are in this family.

## **HYDRONIC or CHILLED WATER SYSTEMS**

In a chilled water system the air is cooled with chilled water passing through the tubes of a finned coil (cooling coil). The refrigerant is used to chill the water, which is circulated throughout the building. When a chilled water system is the refrigeration unit it is called a 'chiller'. These are usually pre-packaged by the manufacturer with the evaporator and condenser attached, so that only water pipes and controls must be run in the field.

Chilled water systems are further categorized as air-cooled or water cooled system depending on how the heat is rejected out of the system. The chilled water system is also called central air conditioning system. This is because the chilled water system can be networked to have multiple cooling coils distributed throughout a large or distributed buildings with the refrigeration equipment (chiller) placed at one base central location. Chilled water systems are typically applied to the large and/or distributed areas. Capacity ranges from 20- 2000 TR and are suitable for an area of 3000 square feet and above.

## **AIR CONDITIONING SYSTEM DESIGN CONFIGURATIONS**

The air-conditioning components and equipment may be designed and assembled in literally a dozen or a hundred different ways but in practice these are broadly classified into three categories:

1. **Centralized Ducted "All – Air" Systems** - These are systems in which the primary movement of heat around the building is via heated and cooled air. These systems are the most common in large spaces such as office buildings, common public areas, retail, shopping, manufacturing areas, airports, hotel lobbies etc.
2. **Centralized Fluid Based Hydronic Systems** - These are systems in which a fluid - typically water but possibly refrigerant - is used to move heat around the building. These systems are fairly common in office rooms, hotel rooms, schools, building perimeter control etc.
3. **Decentralized Systems** - These are systems in which heating and cooling is conducted locally, with little or no bulk movement of heat around the building. Individual unit ventilators are dispersed in small rooms and around the perimeter of a building. These systems are relatively common in schools, small hotels, domestic applications, residential homes and small offices.

The boundaries between these system types are not absolute, but they form useful categories within which to put the many different systems. The choice largely depends on the following -

1. System constraints - Cooling load, zoning requirements, acceptable tolerance to temperature/humidity, degree of control etc
2. Architectural Constraints - Size and appearance of terminal devices, acceptable noise level, space available to house equipment and its location relative to the conditioned space, acceptability of components protruding into the conditioned space
3. Financial Constraints - Capital cost, Operating cost, Maintenance cost

We will review some of the options and issues under each of these categories.

## ALL – AIR SYSTEMS

In an 'All-Air system', the refrigerant or chilled water is used to cool and dehumidify the air in the air handling unit (AHU). The cool air is then circulated throughout the building thru the ductwork. Heating can also be accomplished either by hot water or electrical strip heaters. The centralization of these systems allow for better management and system operation. On the other hand, they also require a mechanical room adjacent to the controlled space for locating the AHU and large ductwork in building space.

The diagram below indicates the main components of a typical air-conditioning system.

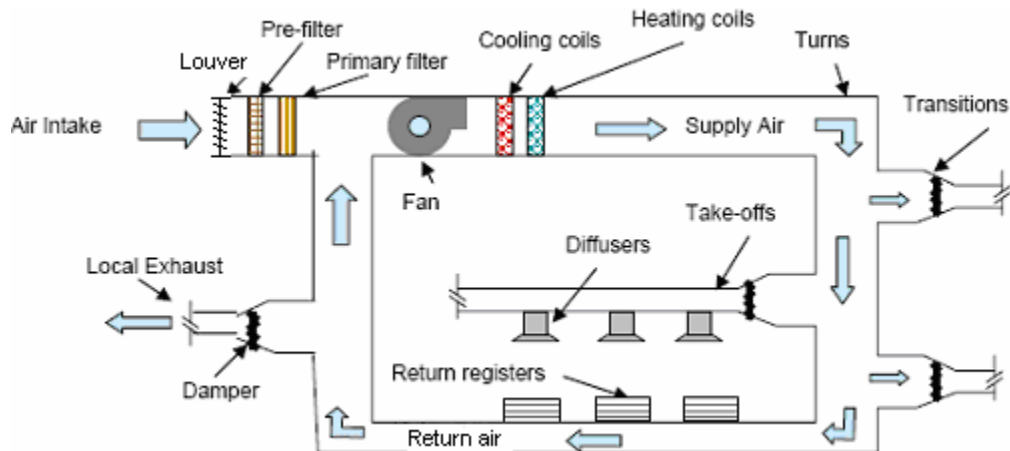

**Typical air-conditioning system**

This is an air-based system, which is the most dominant air-conditioning type for large buildings. Fresh air is drawn into the building through the intake louver, mixed with return air, heated or cooled to a controlled temperature, circulated around the building and provided to the occupied space. Local temperature control is provided by a terminal reheat unit attached to a temperature controller within the occupied space. Exhaust air is extracted from the space and dumped to the outside. In general, the majority of the return air is recycled via the return air duct. The individual components of this system are:

1. **Air Handling Unit** – This is a cabinet that includes or houses the central furnace, air conditioner, or heat pump and the plenum and blower assembly that forces air through the ductwork.
2. **Intake louvers** - These are the external louvers through which supply air is drawn into the building. Intake is generally equipped with volume control damper to regulate the amount of fresh air and economizing the quantity of outside air during favorable outside conditions.
3. **Filters** - These are used to remove particles of dust or dirt from the supply air.
4. **Heating coils** - These heat up the incoming airstream using coils through which hot water is passed over banks of electric heating elements.
5. **Cooling coils** - These cool the incoming airstream using coils through which refrigerant or water is passed.
6. **Supply fans** - These are used to circulate the air through the network of ductwork.
7. **Ductwork** – It is a branching network of round or rectangular tubes generally constructed of sheet metal, fiberglass board, or a flexible plastic and wire composite material located within the walls, floors, and ceilings. The three most common types of duct material used in home construction are metal, fiberglass duct board, and flex-duct.
8. **Supply Ductwork** - These carry air from the air handler to the rooms in a house. Typically each room has at least one supply duct and larger rooms may have several.
9. **Return Ductwork** – These carry air from the conditioned space back to the air handler. Most houses have only one or two main return ducts located in a central area.
10. **Supply and Return Plenums**- These are boxes made of duct board, metal, drywall or wood that distribute air to individual ducts or registers.
11. **Terminal reheat heating coils**- These use hot water coils or electric heating elements to heat up the air being supplied to one part of the building according to the temperature in that space.
12. **Supply and extract grilles** - These are the points at which the air is either supplied into or extracted from the space, and may be ceiling-mounted or wall-mounted. Also called diffusers or registers.
13. **Boots**- These connect ductwork to registers.
14. **Extract fans** - These are used to extract the air from the space and discharge it to outside.
15. **Return air duct** - These are interconnections between inlet and outlet ductwork sections, which let a controlled amount of air recirculate around the air conditioning system when full fresh air is not required.
16. **Exhaust louvers** - These are the external louvers through which extract air is discharged from the building.

## CENTRALIZED AIR CONDITIONING SYSTEMS

<u>System Pros</u>	<u>System Cons</u>
<ol style="list-style-type: none"> <li>1. The central plant is located in unoccupied areas, hence facilitating operating and maintenance, noise control and choice of suitable equipment.</li> <li>2. No piping, electrical wiring or filters are located inside the conditioned space.</li> <li>3. Allows greater energy efficiency by using greater amount of outside air during favorable seasons instead of mechanical refrigeration.</li> <li>4. Seasonal changeover is simple and readily adaptable to climatic control.</li> <li>5. Gives a wide choice of zonability, flexibility, and humidity control under all operating conditions.</li> <li>6. Heat recovery system may be readily incorporated.</li> <li>7. Allows good design flexibility for optimum air distribution, draft control, and local requirements.</li> <li>8. Well suited to applications requiring unusual exhaust makeup.</li> <li>9. Infringes least on perimeter floor space.</li> <li>10. Adapts to winter humidification.</li> <li>11. Is more energy efficient than decentralized systems.</li> </ol>	<ol style="list-style-type: none"> <li>1. Requires additional duct clearance which can reduce the usable floor space.</li> <li>2. Air-balancing is difficult and requires great care.</li> <li>3. Accessibility to terminals demands close cooperation between architectural, mechanical and structural engineers.</li> </ol>

## TYPES OF “ALL-AIR” SYSTEMS

There are three major types of Centralized Ducted Air Systems:

1. Constant Volume Systems
2. Dual Duct Systems
3. Variable Volume Systems

### CONSTANT VOLUME SYSTEMS (CAV)

Constant volume systems deliver a constant volume of air and respond to changing thermal loads by varying air temperature. The air volume is usually based on the design cooling load for the given zone. The ducting and air handling system are sized to match the heat gain from equipment, lights, exterior, and people. Typical applications include:-

1. Space with uniform loads (small office buildings, manufacturing plants, retail etc.)
2. Small spaces requiring precision control

#### System Description

Constant volume systems are a common form of air-conditioning of single thermal zones and are often the system of choice due to simplicity, low cost and reliability. Air is drawn from outside, filtered and then heated or cooled as required. A supply fan then distributes the air through a ductwork network to supply grilles in the space. Air is drawn from the space via extract grilles. The air is then recycled via the return air duct or discharged to the outside through external discharge louvers.

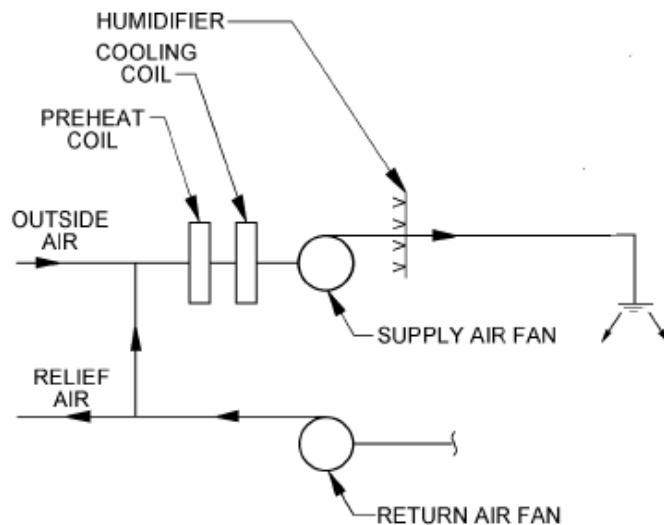

## Constant Volume System

Normally, the equipment is located outside the conditioned space but can also be installed within the conditioned area if conditions permit.

### Controls Configurations

Most CAV systems are small, and serve a single thermal zone. One air handling system is required for each zone because there can be only one supply air temperature at any given time. Air temperature can be varied in the air handling unit to meet the sensible heating or cooling requirement of the zone.

For the typical system serving multiple zones, not all zones will need full cooling at the same time due to unequal loading. For example the perimeter areas with different solar exposures will see different loads throughout the day, while the interior zones will see a fairly constant load. Because the system cannot vary the supply air volume to each zone, some zone air handling systems will have to supply warmer air to maintain the space setpoint. This is achieved by terminal reheat. The terminal reheat units are controlled by a thermostat in the occupied space and apply heating to adjust the air supply temperature to that required to maintain comfortable conditions in the room. This arrangement provides for simple control but is very inefficient, as the supply air is often both cooled and heated, resulting in energy waste.

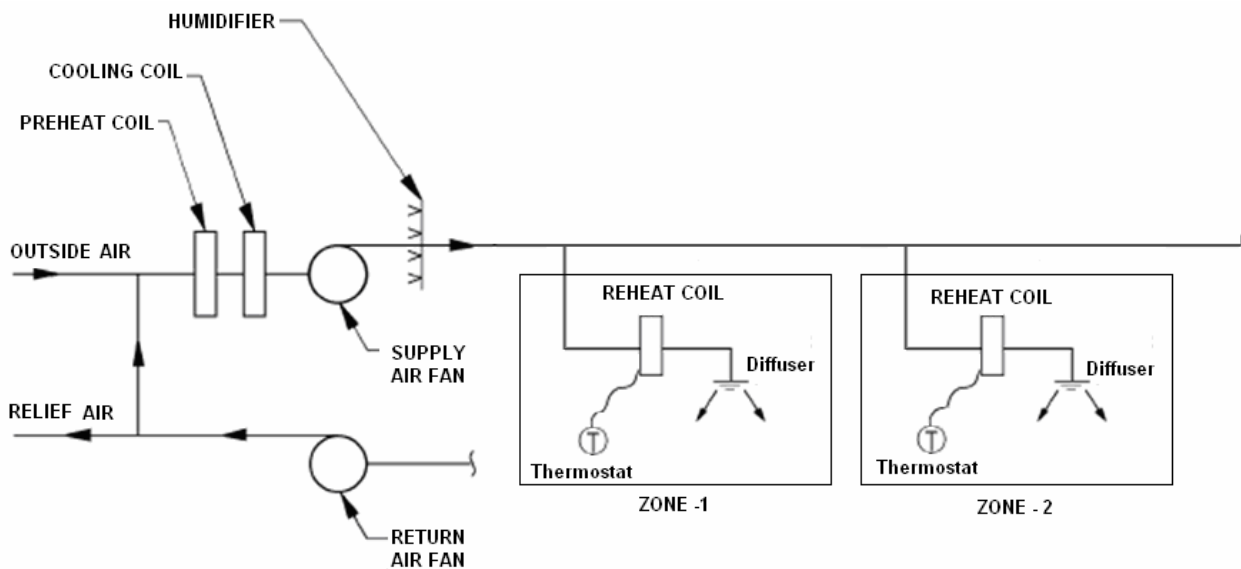

### Constant Volume System with Reheat

Alternative control arrangement for a CAV system serving multiple zones is the use of a "Bypass box". In this arrangement a bypass box with motorized relief damper is added to the branch duct serving a zone. In response to the zone thermostat signal, the relief damper discharges part of the cool air to the open return ceiling thereby restricting the amount of cold air supply to the zone. This is a more energy efficient way compared to the reheat arrangement but is typically applied on the open return above a false ceiling.

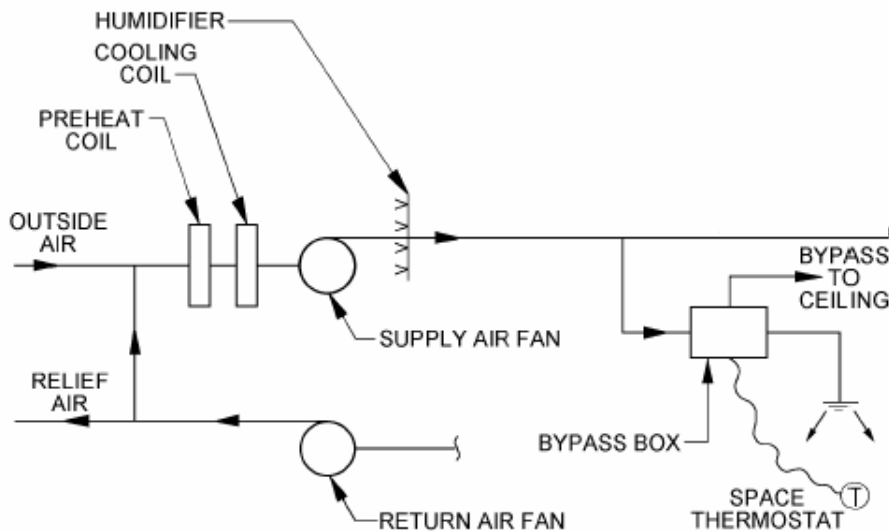

**Constant Volume System with Bypass Box**

**Effectiveness and Internal Comfort**

Constant volume systems are the simplest to install, but all areas receive a preset percentage of the cooling all the time. However, loads can vary dramatically: the number of people, appliances and lights, and solar gain through the windows are unpredictable. With this system, only the area near the thermostat is satisfied all the time. Everyone else is either too hot or too cold.

One path around this problem is to locate the main thermostat in the area with the highest cooling load. Areas requiring less cooling can then have their air flows reheated. This however is a highly energy inefficient method and is prohibited by many codes. One energy efficient system for retrofit or new construction is the variable air volume (VAV). In this system, the quantity of air is reduced to zones with reduced cooling requirements. We will discuss this further in following paragraphs.

As a generic rule, for office areas, large interior zones can be provided with constant volume systems (apply VAV system for perimeter zones). Similarly, shopping corridors, hotel lobbies, and airport concourses can have constant volume systems whereas individual shops, hotel rooms, etc should have individualized VAV controls.

**Energy Saving Considerations**

Constant volume, variable temperature systems use more fan work than VAV systems because they are usually designed for a larger design supply air flow rate, and they cannot modulate the supply air flow rate during part load conditions. The following are some considerations outlined in ASHRAE STD 90.1-1999. The numbers in brackets refer to Std. 90.1-1999 sections.

1. Equipment must be scheduled off automatically during unoccupied hours [6.2.3.1].

2. Adjustment of economy cycle operation to ensure maximum gains are made from the use of fresh air for "free" cooling. Demand Controlled Ventilation is required for systems with at least 3,000 CFM of outdoor air and occupant density greater than 100 people per 1,000 ft<sup>2</sup> [6.2.3.9].
3. Air- or water-side economizers are required. There are several exceptions to this rule, particularly when dealing with heat recovery [6.3.1].
4. Where humidification is required to maintain humidity above 35°F dewpoint, water-side economizers must be used when economizers are required. Introducing large amounts of cool, dry air while meeting the sensible cooling load adds significantly to the humidifier load. Process loads, including hospitals, are exempt [6.3.2.4].
5. Energy recovery is required for systems with at least 5,000 CFM supply air and a minimum of 70% outdoor air. This is specifically aimed at schools and labs [6.3.6.1].
6. For systems under 20,000 CFM, constant volume fans are limited to 1.2 hp/1,000 CFM. For systems over 20,000 CFM, fans are limited to 1.1 hp/1,000 CFM [6.3.3.1].

#### **CONSTANT VOLUME SYSTEMS**

<u><b>System Pros</b></u>	<u><b>System Cons</b></u>
<ol style="list-style-type: none"> <li>1. Easy to design and install</li> <li>2. Dedicated unit per zone offers good temperature control and redundancy.</li> <li>3. Air- or water-side economizers can be added easily to the design to minimize mechanical cooling during cooler weather.</li> <li>4. The main air handling systems can accommodate the ventilation air, avoiding dedicated ventilation equipment.</li> <li>5. Constant volume systems have relatively few moving parts and thus can operate with a reasonable level of reliability.</li> </ol>	<ol style="list-style-type: none"> <li>1. Supply air volume cannot be varied.</li> <li>2. Ducting is oversized and there is a significant fan power penalty.</li> <li>3. Varying the supply air temperature does not guarantee dehumidification.</li> <li>4. Many small systems are needed, each requiring access to the zone it serves.</li> <li>5. Rooftop and self-contained systems offer limited cooling diversity among different zones.</li> <li>6. The control of terminal reheat units is another source of problems. The operation of the thermostat and the valve controlling the terminal reheat unit (where a hot water coil is used) needs regular checking and calibration to ensure that good quality control is maintained.</li> </ol>

## DUAL DUCT SYSTEM

Dual or double duct system is an air conditioning system in which cold and warm air is circulated throughout a building via two parallel ducts. Hot air flows within one duct, cold air within the other. The proportion of hot and cold air delivered to each room within the building may be controlled by thermostatically operated dampers on the ducts outlet. The system is well suited to provide temperature control for individual spaces or zones. Common applications include:

- Office Buildings
- Institutional

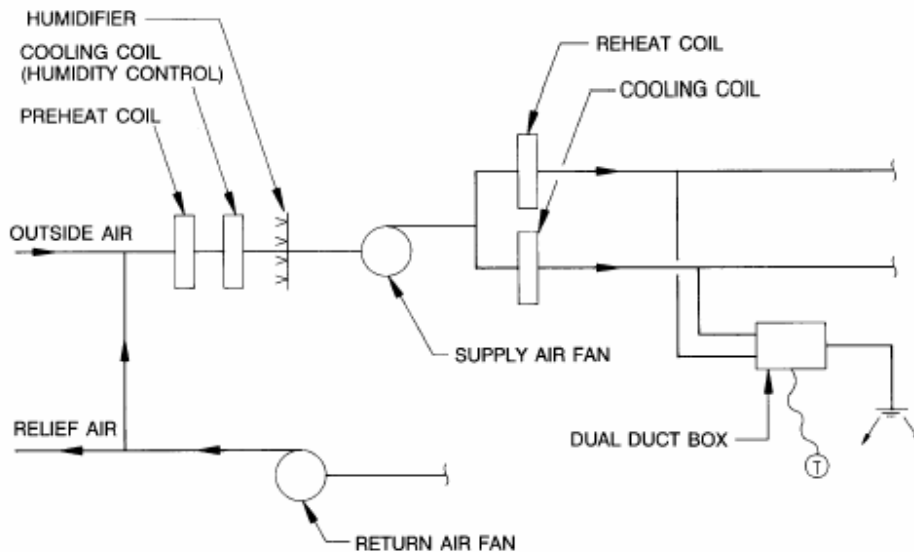

**Dual Duct Constant Air Volume System**

### System Description

Dual-duct all-air systems use two ducts, the first supplying warm air and the second supplying cold air. Air is mixed at the terminal serving the individual space, so that supply air of the desired temperature is delivered to the space. Dual-duct systems are uncommon in new buildings.

### Controls Configurations

There are a number of ways in which a dual-duct system can be controlled. For a typical system serving multiple zones, the air is divided into two, with one supply duct being heated (the "hot deck") and the other cooled (the "cold deck"). In the simplest form of control, the hot deck operates at maximum supply temperature, which is around 84-86°F, while the cold deck operates at minimum supply temperature, which is around 50-55°F. A thermostat in the occupied space controls a mixing box which adjusts the balance of hot and cold air being supplied, to maintain comfortable conditions. The ultimate in control for a system of

this type is to adjust the hot and cold deck temperatures on a continuous basis to match the heating and cooling needs of the building.

**Effectiveness and Internal Comfort**

Dual-duct systems can provide a good quality of servicing but are expensive to install. The quality of temperature control is mainly limited by the way in which rooms are grouped together for temperature control. Often multiple rooms or even the entire face of a building may be served as a single space with only one point of temperature control. This can cause discomfort if individual rooms within this space have different amounts of equipment or sunlight.

**DUAL DUCT SYSTEMS**

<b><u>System Pros</u></b>	<b><u>System Cons</u></b>
<ol style="list-style-type: none"> <li>1. Only the required amount of supply air is used, so fan power is not wasted.</li> <li>2. Systems with terminal volume regulation are self-balancing.</li> <li>3. Zoning of central equipment is not required.</li> <li>4. Instant temperature response is achieved because of simultaneous availability of cold and warm air at each terminal unit.</li> <li>5. No seasonal changeover is necessary.</li> <li>6. There is no simultaneous heating and cooling. Heat in plenum air can be used as reheat.</li> <li>7. Fixed cold air supply temperature maintains humidity control in space.</li> <li>8. Air- or water-side economizers can be added easily to the design to avoid mechanical cooling during cooler weather.</li> <li>9. The main air handling systems can accommodate the ventilation air, avoiding dedicated ventilation equipment.</li> </ol>	<ol style="list-style-type: none"> <li>1. Initial cost is usually higher than other VAV systems. Two ducting systems and two air handling units add to cost.</li> <li>2. Does not operate as economically as other VAV systems.</li> <li>3. Introducing the correct volume of outdoor air into the building is more difficult.</li> <li>4. Providing each zone with the correct amount of outdoor air is more difficult.</li> <li>5. More sophisticated controls are required.</li> <li>6. Large duct shafts from centralized air handling systems are required.</li> <li>7. Dual-duct systems have critical moving parts in the form of the mixing boxes. The operation of the mixing boxes requires regular maintenance to ensure that the overall performance of the system is maintained.</li> <li>8. As with other air-based systems, the balancing of air-flows around the system is critical to the system operation. Regular rebalancing of air-flows is highly recommended to maintain performance.</li> </ol>

## VARIABLE AIR VOLUME SYSTEMS (VAV)

A variable air volume system (VAV) delivers a constant temperature of air and responds to changing thermal loads by varying the quantity of supply air.

Conditioned spaces in buildings are primarily divided into two categories: (1) Perimeter zone, where there are external wall, roofs, and windows and space load varies depending on solar heat, outdoor-indoor temperature difference and internal load; and (2) Interior zone where space loads are mainly internal loads. In an interior zone, the air system often operates at cooling mode in both summer and winter. To account for load variations (in perimeter and interior zones), the VAV system varies the air volume in response to the varying load to maintain predetermined space parameters and conserve fan power.

VAV systems are very common for a wide range of applications. Common applications include:

1. Office Buildings
2. Schools

### System description

The simplest VAV system incorporates one supply duct which distributes approximately 55°F supply air. Each branch duct to individual zones having varied load requirements is equipped with a VAV unit. Because the supply air temperature is constant, the air flow rate is varied to meet the rising and falling heat gains or losses within the thermal zone served.

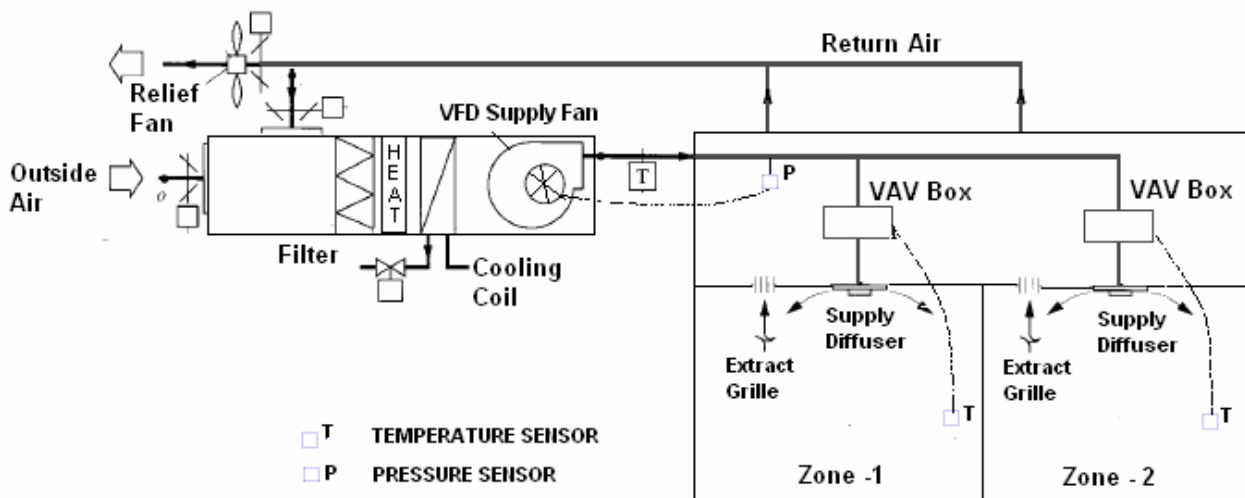

**Variable Air Volume System**

### **Variable air volume system with terminal reheat**

Variable air volume (VAV) systems use variable volume terminal units or boxes to vary the airflow in each zone or space in accordance to the thermostat signals within the space. Heating is turned on when the air flow reaches a predetermined minimum. If more cooling is required, more cold air is introduced into the space.

In the best implementation of these systems, the central air handling unit fan speed is controlled to maintain a constant duct pressure. An interlock is arranged between the supply and extract fans. Variable air volume systems are very common in larger office buildings.

### **Controls configurations**

Variable air volume (VAV) with reheat systems provide conditioned air to each zone at a constant temperature, typically 55°F. The amount of air varies to match the heat gain from equipment, lights, exterior and people. At part load conditions, VAV systems supply only the necessary amount of conditioned air to each zone, saving significant fan energy.

A zone temperature sensor is used to control a damper that is arranged to maximize air-flow when heating or cooling loads are high and cut down to minimum air when loads are low. When more dampers close, the duct system static pressure increases. The primary supply fan adjusts to maintain duct static pressure using discharge dampers (FC fans only), inlet guide vanes, or variable frequency drives (VFDs). Control of the system's fan capacity is critical in VAV systems. Without proper and rapid flow rate control, the system's ductwork, or its sealing, can easily be damaged by over-pressurization. Automatic controls for the fan are generally comprised of a speed modulating control to the fan motor to maintain a constant pressure in the supply duct. However, in some systems, variable volume control may be achieved by other methods, such as a damper restricting the flow or the adjustment of fan blades.

The control of supply duct temperature is similar to that of a constant volume system. In many buildings, the air in the supply duct is heated or cooled to a constant temperature of typically 14-16°C. The terminal reheat units are controlled by a thermostat in the occupied space and apply heating to adjust the air supply temperature to that required to maintain comfortable conditions in the room. Because the airflow is variable, this simple control arrangement does not produce the inefficiencies present in constant volume systems. More complex control of duct temperature is feasible, following the same "hi select" methods as described for constant volume systems. However, as long as the minimum air-flow in the system is substantially smaller than the maximum airflow, and the variable volume components of the system are operating correctly, additional control complexity is not necessary.

## **Effectiveness and internal comfort**

VAV systems provide very good control and a high level of flexibility in operation. The internal comfort control is generally good, but there can be problems when air flows are low. In particular, there may be problems with ensuring that adequate fresh air is supplied to individual zones and also low flows of air mixes poorly with the air in the room and instead drops directly from the supply diffuser, causing discomfort for anyone sitting immediately below. There can also be problems with air "whistling" past the variable volume dampers under certain conditions. However this can be offset by setting the VAV boxes to provide a minimum amount of air, even if that amount exceeds cooling requirements. While this maintains air turnovers and minimum outdoor air ventilation rates, the zone may be overcooled and reheat may be required, resulting in simultaneous heating and cooling. ASHRAE Standard 90.1-1999 requires the minimum supply air volume to be the ventilation rate for the zone for most applications.

A properly functioning variable air-volume system is very efficient because it has minimal simultaneous heating and cooling and low fan energy.

## **Type of Variable air volume terminal units**

There are generally five different types of units that are used: pressure-independent volume units; pressure-dependent, airflow-limiting, maximum volume units; pressure-dependent units; bypass (dumping) units; and supply outlet throttling units. One other type of unit that is used is the fan-powered variable air volume terminal unit.

1. **Pressure – Independent Units** - Pressure-independent volume units regulate the flow rate in response to its respective thermostat's call for heating or cooling. The thermostat controls airflow to the space by varying the position of a simple damper or volume regulating device located in the unit. The required flow rate is maintained, regardless of the fluctuation of the system pressure being supplied by the air handling unit supply fan. These units can be field- or factory-adjusted for maximum and minimum airflow settings.
2. **Pressure Dependent-Airflow Limiting Maximum Volume Units** - A pressure-dependent, airflow-limiting, maximum volume unit regulates maximum volume, but the flow rate will oscillate when system pressure varies. These units are less expensive than pressure-independent units. These units can be used where pressure independence is required only at maximum airflow, where system pressure variations are relatively small, and where some degree of fluctuation or "hunting" is tolerable.
3. **Pressure Dependent Units** - Pressure-dependent units do not regulate the flow rate, but position the volume regulating device in response to the thermostat. These units are the least expensive and should only be used where there is no need for maximum or minimum airflow control and the air handling unit system pressure is stable.
4. **Bypass Dumping Units** - Generally, in small air handling systems, the cost of a variable air volume system is too high. However, by using bypass (dumping) units in certain zones or spaces, the constant

volume system can have variable airflow control. The thermostat controls airflow to the space by varying the position of the volume regulating device. If less air is required to the space, the regulating device closes down and bypasses or diverts some of the air to the return ceiling plenum or return air duct. This technique is very effective for constant volume systems.

5. **Supply Outlet Throttling Units** - Supply outlet throttling units are usually linear diffusers. The area of the throat or the discharge opening varies in approximate proportion to the air volume to maintain throw patterns. The thermostats are usually located at the outlet of the diffuser for easy temperature adjustment. Since these units are pressure-dependent, constant pressure regulators are usually required in the duct system. Noise is a concern when using these units in occupied spaces.
6. **Fan Powered Variable Air Volume Units** - Fan-powered variable air volume units are available in two types: parallel and series flow units. The units have the same components as pressure-dependent or pressure-independent volume units, and in addition, a fan and usually an electric or hot water heating coil. Fan-powered variable air volume units, both series and parallel, are often used for building perimeter heating, because they move more air through a room at low cooling loads and during the heating cycles compared to variable air volume reheat or perimeter radiation systems.

### **Energy Considerations**

Varying the supply air volume reduces fan work, a major use of building energy. The following are some considerations outlined in ASHRAE Std 90.1-1999. The numbers in brackets refer to Std. 90.1-1999 sections.

1. Equipment must be scheduled off automatically during unoccupied hours [6.2.3.2].
2. Demand Controlled Ventilation is needed for systems with at least 3,000 CFM of outdoor air and an occupant density greater than 100 people per 1,000 ft<sup>2</sup> [6.2.3.9].
3. Where humidification is needed to maintain humidity above 35°F dewpoint, water-side economizers must be used when economizers are needed. Introducing large amounts of cool, dry air while meeting the sensible cooling load adds significantly to the humidifier load. Process loads, including hospitals, are exempt (6.3.2.4). • For systems under 20,000 CFM, VAV is limited to 1.7 hp/1,000 CFM. For systems over 20,000 CFM, VAV systems are limited to 1.5 hp/1,000 CFM [6.3.3.1].
4. 30 hp and larger fan motors must use no more than 30% of design power at 50% airflow [6.3.3.2].
5. Energy recovery is required for systems with at least 5,000 CFM supply air and a minimum of 70% outdoor air. This is specifically aimed at schools and labs [6.3.6.1].

## VARIABLE AIR VOLUME SYSTEMS

<u>System Pros</u>	<u>System Cons</u>
<ol style="list-style-type: none"> <li>1. Only the necessary amount of primary air is used, conserving primary fan power.</li> <li>2. Diversity is applied to supply air volume, reducing duct and fan sizes.</li> <li>3. Capital cost is lower since diversities of loads from lights, occupancy, solar and equipment of as much as 30% are permitted.</li> <li>4. Virtually self-balancing.</li> <li>5. It is easy and inexpensive to subdivide into new zones and to handle increased loads with new tenancy or usage if load does not exceed the original design simultaneous peak.</li> <li>6. No zoning is required in central equipment.</li> <li>7. Lower operating cost because fans run long hours at reduced volume</li> <li>8. Refrigeration, heating and pumping matches diversity of loads</li> <li>9. Unoccupied areas may be fully cut-off</li> <li>10. Allows simultaneous heating and cooling without seasonal changeover</li> <li>11. Air- or water-side economizers can be added easily to the design to minimize mechanical cooling during cooler weather.</li> <li>12. Air handling unit can maintain minimum outside air amounts, avoiding the need for dedicated ventilation equipment.</li> </ol>	<ol style="list-style-type: none"> <li>1. Difficult to consistently maintain minimum outdoor air quantities entering the building.</li> <li>2. Difficult to consistently maintain the correct amount of outdoor air in each zone.</li> <li>3. Requires sophisticated controls.</li> <li>4. Simultaneous heating and cooling occurs once the minimum air volume is reached in a zone.</li> <li>5. A separate, distributed heating system is needed for cooler climates.</li> <li>6. The variable volume dampers, either as VAV boxes in the ceiling space or as variable volume diffusers, can be maintenance-intensive items. A variable volume system with poorly functioning variable volume functions is in essence just a constant volume system. As a result, regular maintenance and calibration of variable volume equipment is essential for good system performance.</li> <li>7. If the air supply volume to different spaces falls out of adjustment, then individual rooms and sometimes even entire floors can become quite uncomfortable and the system can become inefficient.</li> <li>8. The control of terminal reheat units is another source of potential hazards. The operation of thermostats and the valve controlling the terminal reheat unit needs regular checking and calibration to ensure that good quality control is maintained.</li> </ol>

## **CENTRAL FLUID BASED HYDRONIC SYSTEMS**

Central fluid based hydronic systems use terminal units to condition the air. The term hydronic refers to an air-conditioning system that uses water for distribution of heat. Cooling and dehumidification is provided by circulating chilled water through a finned coil in the unit whereas heating is provided by supplying hot water through the same or a separate coil.

### **Why Fluid based Systems?**

1. Water has greater specific heat and density compared to air and therefore water can convey a lot of heat per unit volume. The distribution elements (pipes) are typically smaller than that of air distribution ductwork.
2. Zone control is easy and the individual equipment can be shut off during unoccupied hours. Typical application is hotel rooms and multiple small zones.
3. Fluid based systems require small primary air for ventilation purposes. The system relies on 100% recirculation air and there is no return air system.
4. The power required to pump water through the building is usually less than the fan power needed for supply air and return air systems.
5. The fluid based system in combination with provision for ventilation air can match versatility of all-air systems. Positive ventilation, central dehumidification, winter humidification, and good temperature control over a number of control zones are capable with the system.

Centralized fluid-based systems come in a variety of radically different forms. Key types of fluid-based system are:

1. Hydronic system (All – Water System)
2. Fan-coil system
3. Induction system
4. Variable Refrigerant Volume system (VRV)
5. Hybrid system (using both all-fluid and all-water arrangement)

### **'ALL – WATER' HYDRONIC SYSTEMS**

In an all-water hydronic system, the hot or cold-water is distributed to individual heat transfer devices (terminal units) located in each room of the building. When heating, the terminal units draw heat from the water and when cooling these reject heat to the water. The biggest drawback of all-water hydronic system is the difficulty in providing adequate indoor air quality. Due to this concern, these systems should not be applied to occupied areas and are ideally suited for machinery rooms, substations etc.

An All-Water system uses the following basic components:

1. The use of a chiller (on roofs or plant rooms) to cool the water which would be circulated via circulating pumps to the terminal units (example fan coil units) located in the occupied space.
2. The use of boilers (in plant rooms) to heat the water which would be circulated via circulating pumps to the terminal units located in the occupied space. Hydronic heating systems employ a variety of terminal units that include fan coil units, baseboard radiators, convectors, unit heaters, and radiant floors.

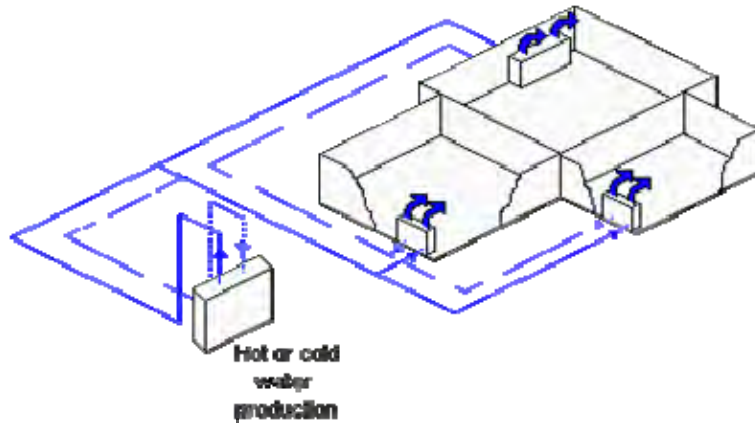

Hydronic systems are designated by how the seasonal switch over from heating to cooling occurs. The hydronic system piping can be arranged in 3 basic configurations: (1) Two-pipe system, (2) Three-pipe system and (3) Four-pipe system.

### **Two Pipe Systems**

Two pipe systems consist of a network of insulated pipes; one pipe supplies chilled water and the second pipe returns it to the chiller. The secondary water is cold in summer and intermediate seasons and warm in winter. With water-changeover, chilled water is circulated during the cooling season and hot water during the heating season. The problems occur during the mid-seasons where cooling can be required part of the time and heating part of the time and no heating or cooling the rest of the time.

Two pipe systems without water-changeover circulate chilled water only and provide heat where it is needed by electric strip heat at the terminal units. In some cases, hot water is circulated during the coldest part of the heating season to reduce operating cost.

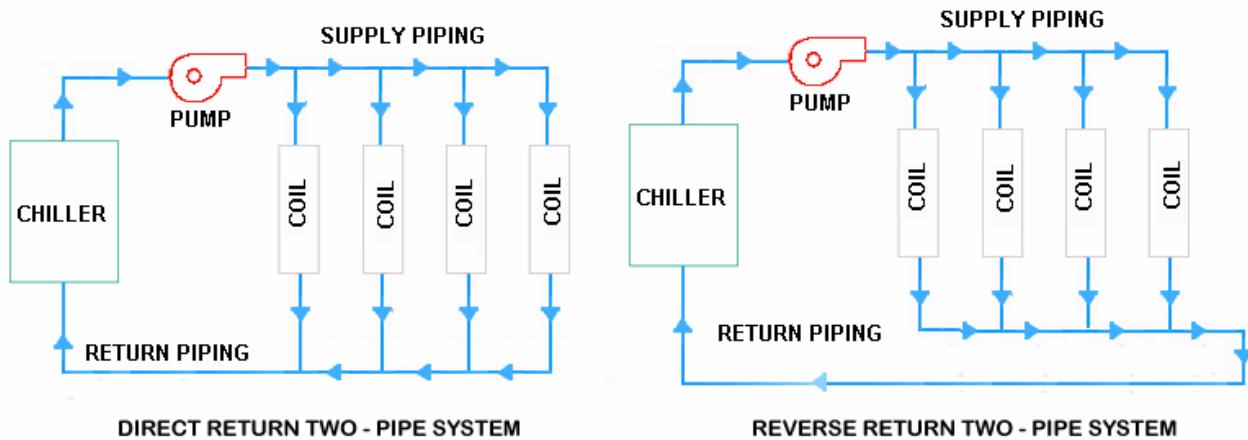

The primary air quantity is fixed and the primary air temperature control is achieved by varying the water supply through the coil. When thermostat sensors demand more cooling, the two or 3-way valve located on the line is in the full open position.

### TWO-PIPE SYSTEM

<u>System Pros</u>	<u>System Cons</u>
<ol style="list-style-type: none"> <li>Usually less expensive to install than four pipe systems</li> </ol>	<ol style="list-style-type: none"> <li>Less capable of handling widely varying loads or providing widely varying choice of room temperature compared to four-pipe systems</li> <li>Cumbersome to change over and the problem is acute on the shoulder months (spring and fall) when the occupants need heat in the cool mornings and cooling in the warmer afternoons.</li> <li>Though it is economical initially on first cost, it is more costly to operate than four-pipe systems.</li> </ol>

### Three- Pipe System

In the three pipe system, hot water and chilled water are fed to each fan coil, with a common return. This is somewhat more expensive than a 2-pipe system, since a third pipe must be run to each unit. Since the hot water and cold water are mixed in the return, these inefficient systems are seldomly installed today.

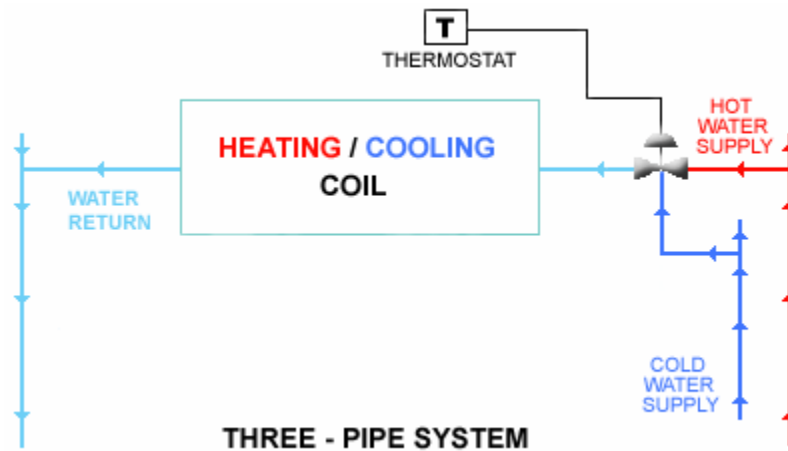

### **Four-Pipe System**

In the four pipe system, the chilled water loop and the hot water loop are completely separate. While these systems are most expensive to install, they are easier to operate in unpredictable climates.

The system is further categorized as independent load systems and common load systems.

- 1) Independent load systems have two separate water coils, one served by hot water, the other by cold water. The systems make use of a 2-way on-off valve.
- 2) Common load systems can have a single coil in the air handler but still supply independently with a 4-pipe system. The systems make use of 3-way diverting valves.

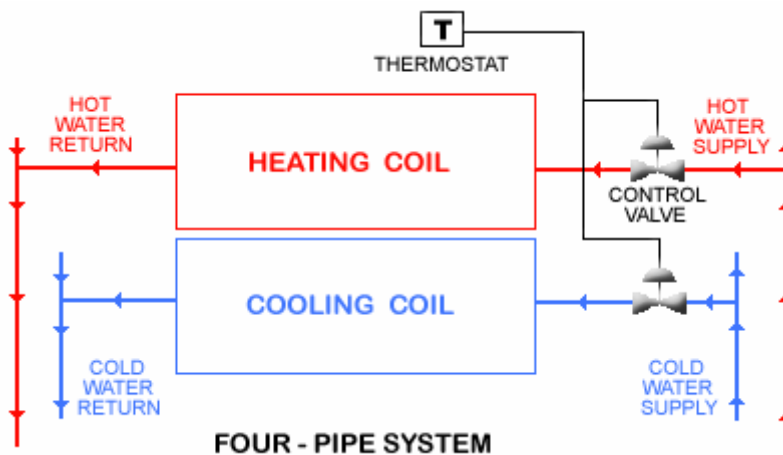

Note that the water flow rate required for heating is much lower than the chilled water flow. It is better to use a 4-pipe system, which allows the use of smaller size piping and pumps for lower hot water flow rates.

### FOUR-PIPE SYSTEM

<u>System Pros</u>	<u>System Cons</u>
<ol style="list-style-type: none"> <li>1. All year availability of heating and cooling with individual zone temperature control.</li> <li>2. Chilled and hot water could be simultaneously supplied during the Spring and Fall seasons.</li> <li>3. Elimination of zoning cost and complexity.</li> <li>4. Simpler changeover decisions (No summer-winter changeover and primary air reheat schedule).</li> <li>5. The lowest and quietest fan speed is adequate most of the time.</li> <li>6. More flexible and adaptable to widely varying loads.</li> </ol>	<ol style="list-style-type: none"> <li>1. Four-pipe systems have a high first cost due to the second water system and the need for either two coils or more costly control valves at each terminal unit.</li> <li>2. The systems also have a high operating cost due to the two pumps operating (though provide good flexibility in meeting varying loads).</li> </ol>

### HYBRID SYSTEMS

Hybrid systems use both air and water (cooled or heated in a central plant room) distribution to room terminals to perform cooling or heating function. Unlike all-water systems, this system ensures ventilation air in the spaces so that indoor air quality is not sacrificed.

#### Air Portion of the System

The air side is comprised of central air conditioning equipment, a duct distribution system, and a room terminal. The supply air, called primary air, usually has a constant volume which is determined by the need for outside (fresh) air for ventilation. When in cooling mode the primary air is dehumidified by a central conditioning unit to provide comfort and prevent condensation. In the winter heating mode, the air is humidified by the central conditioning unit to limit dryness.

Water Portion of the system

The water side consists of a pump and piping to convey water to heat transfer surfaces within each conditioned space. The water used can be chilled by direct refrigeration, by using chilled water from a primary cooling system, or by heat transfer through a water-to-water exchanger. Chillers usually supply chilled water anywhere from 35-48°F. Individual room temperature control is by regulation of either the water flow through it or the air flow over it. In the winter, the heating capacity of the coil in a conditioned space must be great enough to heat the space and offset the cool primary air, which is provided.

**HYBRID SYSTEMS**

<u><b>System Pros</b></u>	<u><b>System Cons</b></u>
<ol style="list-style-type: none"><li>1. Flexible and readily adaptable to many building module requirements.</li><li>2. Provides individual room control.</li><li>3. The power required to pump water through the building is usually less than the fan power needed for supply air and return air systems.</li><li>4. Very good control is available over many zones.</li><li>5. Heating and Cooling can be available for all zones allowing variation of loads.</li><li>6. Space needed for distribution system is minimal.</li><li>7. Energy savings are achieved by using water instead of air to deliver heating and cooling to the space.</li><li>8. Cross contamination is reduced because recirculation occurs within rooms.</li></ol>	<ol style="list-style-type: none"><li>1. No positive ventilation is provided unless wall openings are used.</li><li>2. No humidification is provided.</li><li>3. Seasonal change over is required.</li><li>4. Maintenance and service work has to be done in the occupied areas.</li><li>5. Design of between season operations is crucial as a result of the low primary air delivered.</li><li>6. Terminal unit filters must be changed often due to secondary airflow.</li></ol>

## FAN COIL UNITS

A fan coil conditioner unit is a type of room terminal unit that can be used with water-only (all-water) or air-water systems. In the air-water system the fan-coil conditioner unit provides the heating or cooling to a space while the primary air system supplies all ventilation.

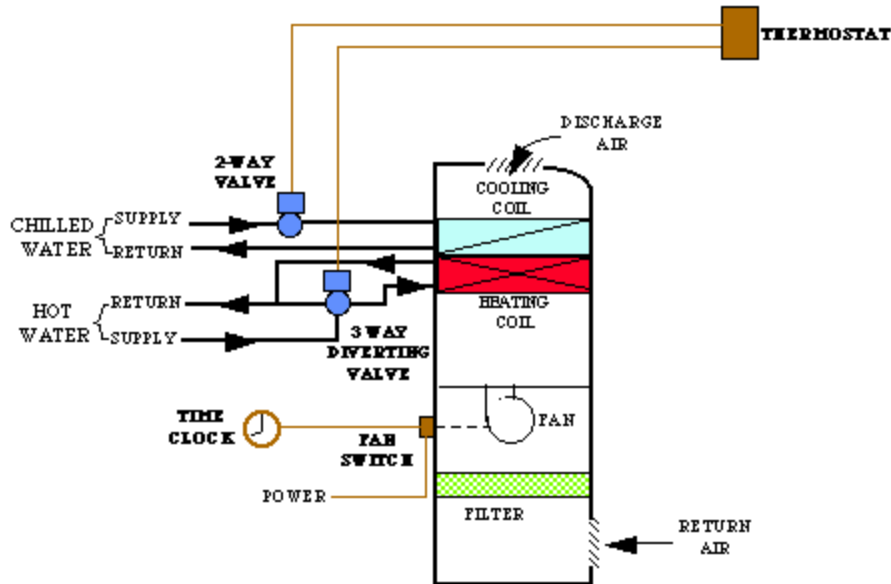

**Fan-Coil Unit using 4-way piping for heating and cooling along with 2-way and 3-way diverter valve for temperature control**

### System description

A fan-coil unit is a relatively simple air-conditioning equipment that is placed at each place which needs to be heated or cooled. The fan-coil conditioner consists of a fan, filter and coil. The fan draws in room air and passes it through the filter and then by the coil to either heat or cool it and then returns it to the room to control the temperature and particulates. The coils have chilled water or low temperature hot water (LTHW) passing through them, which is supplied at a central location. Where there is a single coil this can be arranged to provide heating and/or cooling according to requirements. Where there are two coils, one is arranged to provide heating and the other cooling. This configuration is referred to as a four-pipe fan-coil unit (as shown in schematic above).

The fan units are available in various configurations that can be either wall mounted or ceiling mounted. Variations may take the form of two-pipe fan-coil units, with a single cooling or heating coil, or may use an electrical heating coil in place of a LTHW coil. Auxiliary air may be delivered to the conditioned space for dehumidification and ventilation purposes.

Units are available in standard capacities of 200, 300, 400, 600, 800, and 1200 CFM.

### **Design Recommendations**

In order to make a proper fan coil unit selection, the whole air conditioning system must be looked at because sizing a fan coil unit is not just matching the room load. Other criteria which must be considered during selection are; the minimum room load, fresh air requirements, with or without reheat, 2 or 4-pipe system, zone size, flexibility and maximum noise level in the room, etc.

The cooling capacity which is supplied to the room is the sum of cooling energy available in the primary air and the cooling capacity of the fan coil unit. The way the primary air is supplied to the room determines a great part of the required fan coil cooling capacity.

The most common methods to supply primary air are shown on the following page:

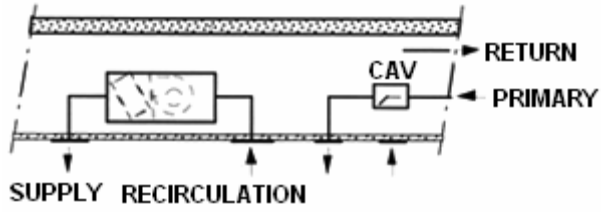
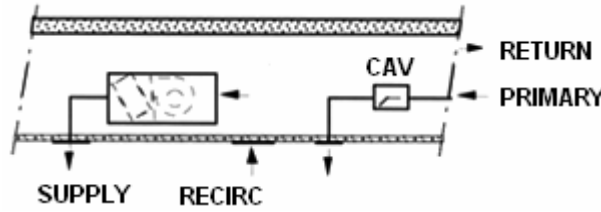
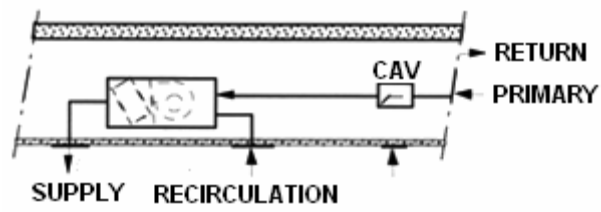
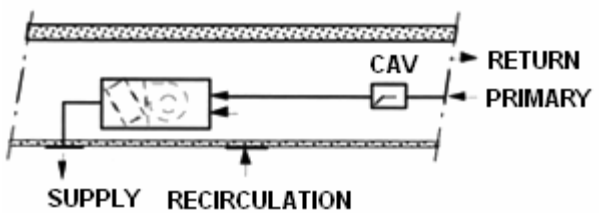
Applications	Schematic
<p><b>System-1:</b> This is the most energy efficient system. Primary air is supplied directly into the room and the recirculation diffuser is ducted to the inlet of the fan coil unit. For this case the cooling energy available in the primary air can be deducted from the room load. An additional benefit with this configuration is the fan coil unit can be switched off in situations where primary air only is sufficient to maintain the required room conditions or when ventilation only is required.</p>	
<p><b>System-2:</b> Primary air is supplied directly into the room and recirculation air is taken from the ceiling void. This is basically the same as system-1; however the cooling capacity must be higher because the temperature in the ceiling void is normally higher than in the room.</p>	
<p><b>System-3:</b> Primary air and recirculation air are both ducted to the intake of the fan coil unit. For this case, the entering air for the heat exchanger is lower in temperature and less humid than at system-1. The required cooling capacity from the fan coil unit is equal to system-1, however the air volume must be higher to supply both the primary and fan coil capacities of system-1.</p>	
<p><b>System-4:</b> Primary air is ducted to the intake of the fan coil unit and recirculation air is taken from the ceiling void. This is basically the same as system-3; however the cooling capacity must be higher because the temperature in the ceiling void is normally higher than in the room.</p>	

When primary air is supplied near the intake of the fan coil unit, part of the primary air will be lost directly into the exhaust system wasting conditioned air energy. This is wasting energy and should be avoided. To demonstrate the difference in energy consumption, an analysis is indicated below:

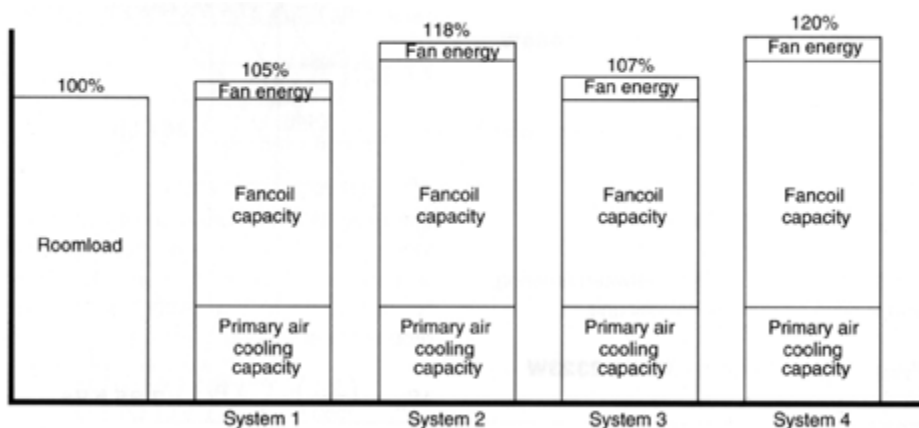

**Controls configurations**

Automatic controls for the fan-coil unit are generally comprised of an ON-OFF control to the fan motor, often in conjunction with three speed settings. A remote room temperature sensor is used to control both the fan motor and modulating valves on the heating coil and the cooling coil, and or three speed setting control to the fan motor.

**Effectiveness and internal comfort**

Fan-coil units provide excellent comfort levels for individual areas. With the temperature sensor located in the space, the heating or cooling provided by the fan-coil unit can be tempered according to the needs of the individual space.

Units with an outdoor air supply combine good temperature control with the ability to meet requirements for fresh air to be supplied to the space.

The fault most often identified in relation to fan-coil units relates to noise, as the fan is close to the occupied space. However, with a well-designed unit with a quiet fan and good sound attenuation this does not need to be an issue.

**Maintenance and Balancing Considerations**

The fan-coil unit is a free-standing unit and thus balancing is not required except if a ducted system is used to provide fresh air to the units. Balancing and commissioning of any ducted fresh air system may need adjustment, possibly affecting the output from the unit or the comfort in the space. The LTHW heating circuit or the chilled water circuit may need re-balancing or re-commissioning if indicated by poor performance of the unit in either cooling or heating mode.

Typically fan-coil systems have a large number of thermostats. Regular calibration of these thermostats is necessary.

If a fan-coil unit has a filter, this needs to be cleaned regularly as otherwise the air-flow may be reduced, which in turn affects the ability of the unit to properly heat and cool the occupied space.

**Energy Saving Opportunities**

The key areas for energy savings are:

1. Thermostats need to be calibrated regularly. In open-plan offices, poor calibration can cause adjacent units to "fight", with one unit heating and the other cooling.
2. Filters need to be cleaned regularly.
3. Fan-coils work well with hybrid ventilation systems. Interlocks can be arranged between the fan-coil unit in a space and the windows in the space, such that the unit switches off when the window is opened. This avoids the fan-coil unit heating or cooling the space when significant outdoor air is being introduced.

**FAN COIL UNITS**

<b><u>System Pros</u></b>	<b><u>System Cons</u></b>
<ol style="list-style-type: none"> <li>1. Individual room temperature control.</li> <li>2. Separate sources of heating and cooling for each space available as needed to satisfy a wide range of load variations.</li> <li>3. Low distribution system space required as a result of reducing the air supply by use of secondary water for cooling and high velocity air design.</li> <li>4. Reduced size of central air handling equipment.</li> <li>5. Dehumidification &amp; filtration performed in a central plant room remote from conditioned space.</li> <li>6. Outdoor air supply is positive.</li> <li>7. Zoning of central equipment is not required.</li> </ol>	<ol style="list-style-type: none"> <li>1. Limited to perimeter space.</li> <li>2. The primary air supply is usually constant with no provision for shutoff.</li> <li>3. Not applicable to spaces with high exhaust requirement.</li> <li>4. Seasonal changeover is necessary.</li> </ol>

## INDUCTION UNITS

The inducing system is designed for use in perimeter rooms of multi-storey, multi-room buildings that may have reversing sensible heat characteristics. It is especially adapted to handle the loads of skyscrapers with minimum space requirements for mechanical equipment. Induction units are usually installed at a perimeter wall under a window. Some hotel rooms are provided with induction coils.

### System description

Induction units are effectively a variant of a fan-coil unit. Instead of using a fan, primary air is injected into the unit at high velocity from nozzles, which induces a secondary air flow from the conditioned space - hence the name. The induced air flows over a cooling or heating coil to provide room temperature control.

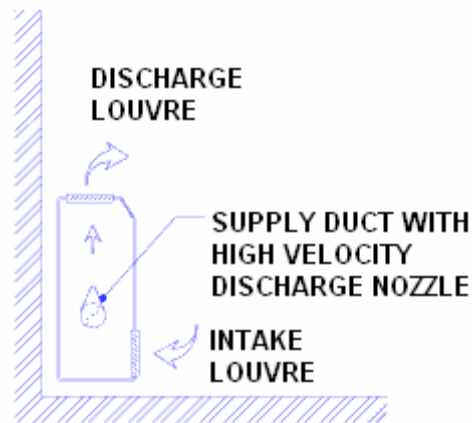

**Induction unit**

In an induction system, ducted primary air is fed into a small plenum chamber where it is delivered through nozzles as high velocity jets. This induces secondary air from the room across the secondary coil. The right quantity of high pressure air is adjusted automatically in response to a thermostat located in the conditioned space. If the primary air alone provides sufficient temperature control, then an internal damper in the unit causes the induced secondary air to bypass the coil. Otherwise the induced air is heated or cooled through the coil.

Induction units are served by hot water and/or chilled water which is generated by a central plant. Variations may take the form of two-pipe induction units, with a single cooling or heating coil, or may use electrical heating.

Induction units are comparatively rare and not used in new installations.

**Controls Configuration**

Automatic controls for the induction unit comprise operation of the internal damper and/or heating and cooling coils according to a remote temperature sensor located in the space. The temperature of the primary air may also be varied according to the external ambient temperature or season.

**Effectiveness and internal comfort**

Induction unit installations can provide good comfort levels due to the individual room temperature control provided. Fresh air is also supplied to the space by the units.

Due to the increased air velocity from the primary air jet nozzles some noise may be generated by the induction units. With careful design this noise can be controlled to an acceptable level. The plenum is usually acoustically treated to attenuate part of the noise generated in the duct system and in the unit.

**Energy saving opportunities**

The energy savings opportunities for induction units are:

1. Room thermostats need to be calibrated regularly. Poor calibration may lead to overheating or overcooling which will waste energy.
2. Regular cleaning and adjustment of the primary air jet nozzles is important for the effective operation of the induction unit.
3. Air filters must be cleaned regularly

**INDUCTION UNITS**

<b><u>System Pros</u></b>	<b><u>System Cons</u></b>
<p>In addition to the advantages of Fan-coil units, the induction units have:</p> <ol style="list-style-type: none"> <li>1. Minimal maintenance required as individual induction units have no moving parts, i.e. no fans</li> <li>2. Without fans, these units provide a quieter space.</li> </ol>	<p>In addition to the disadvantages listed for fan coil units, for induction units:</p> <ol style="list-style-type: none"> <li>1. Installation requires the installation of both ductwork and pipework to the conventionally free-standing wall-mounted units.</li> <li>2. Induction units can be complex to commission, when air balancing as well as heating and cooling water flows must be correctly set.</li> <li>3. The primary air supply is usually constant with no provision for shutoff.</li> </ol>

<u>System Pros</u>	<u>System Cons</u>
	<ol style="list-style-type: none"> <li>4. Higher energy consumption due to increased power required by the primary pressure drop in the terminal units.</li> <li>5. Controls tend to be more complex than for all-air systems.</li> <li>6. Initial cost is usually higher than fan coil systems.</li> </ol>

**VARIABLE REFRIGERANT VOLUME SYSTEMS**

In a VRV system, refrigerant runs around the building to individual fan-coils that can provide heating or cooling as required.

**System description**

Variable refrigerant volume (VRV) units comprise a number of room units which share a common refrigerant circuit, served from a common outdoor unit. Each of the room units can either heat or cool depending on how the refrigerant is used within the coil. Indoor units should be relatively near to one another, and the distance to the common outdoor unit kept to a minimum. The indoor units are similar in their operation to the split system air-conditioning unit.

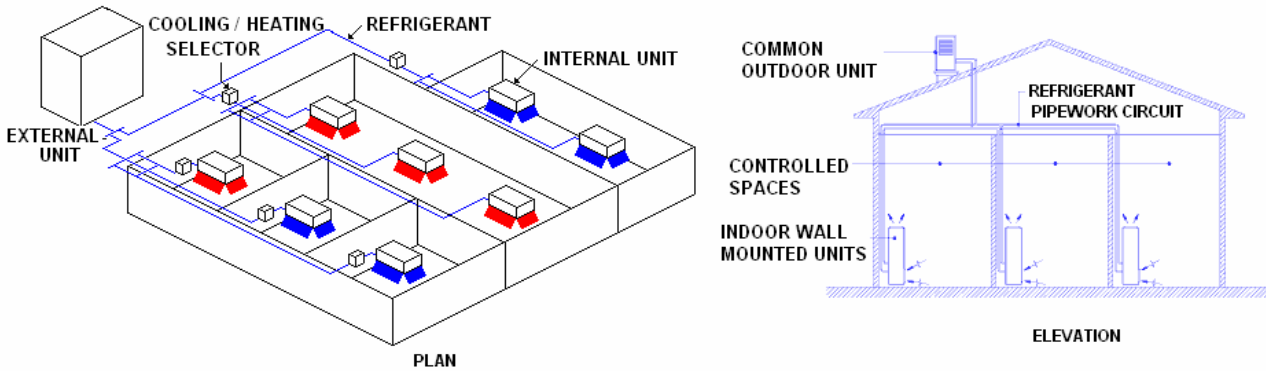

**Variable Volume Refrigerant Units**

### **Controls Configurations**

Automatic controls for the fan-coil unit generally comprise of on-off control to the fan motor, often in conjunction with three speed settings. A remote room temperature sensor is used to control both the fan motor and modulating valves on the heating coil and the cooling coil, and/or three speed setting control to the fan motor.

### **Effectiveness and Internal Comfort**

VRV air-conditioning units provide good comfort levels, although noise made by the internal units may be noticeable. With the temperature sensor located in the space, the heating or cooling provided by the fan-coil unit can be tempered according to the needs of the individual space.

VRV systems have the special feature that they can transfer heat around the building. Thus if a building requires heating in one area and cooling in another, the energy removed from the overheated area can in effect be transported to the cooler area. This can produce savings in buildings where heating and cooling requirements are diverse.

### **Maintenance and Balancing Considerations**

VRV systems do not in general require balancing. Maintenance to the refrigeration system is required to ensure that their operation is satisfactory and that lifespan is maximized. The air filters on the intake grilles will require cleaning, according to the quality of the environment and the frequency of use of the units.

### **Energy Saving Opportunities**

The key areas for energy savings are:

1. Regular maintenance to the refrigeration unit will improve both efficiency and effectiveness.
2. Cleaning of air intake filters is essential to maintain both performance and efficiency.
3. VRV units work well with hybrid ventilation systems. Interlocks can be arranged between the VRV air-conditioning unit in a space and the windows in the space, such that the unit switches off when the window is opened. This avoids the unit heating or cooling the space when significant outdoor air is being introduced.

### **DECENTRALIZED SYSTEMS**

Decentralized systems are small air conditioner units that provide cooling only where needed rather than the entire space and these essentially cool small rooms. These are essentially direct expansion (DX) systems, which operate using direct expansion of refrigerant in the finned tubes across the air path.

Decentralized systems are often used as after hours support for centralized systems, allowing specific areas to be air-conditioned without requiring the operation of the central plant. In such applications, both the central system and the decentralized units are sized to cool the particular conditioned space adequately without the other operating. In other applications, where decentralized units are added to supplement an

inadequate existing system, they are selected and sized to meet the required capacity when both systems operate.

In smaller buildings, these are less expensive to operate than central units, even though their efficiency is generally lower than that of central air conditioners. Smaller room air conditioners (*i.e., those drawing less than 7.5 amps of electricity*) can be plugged into any 15- or 20-amp, 115-volt household circuit that is not shared with any other major appliances. Larger room air conditioners (*i.e., those drawing more than 7.5 amps*) need their own dedicated 230-volt circuit.

The major types of decentralized systems are:

1. Split Systems
2. Window Units
3. Heat Pumps

All these comprise of a hermetically sealed compress(s), evaporator (cooling coil fabricated out of copper tubes and aluminum fins), a supply air fan, filter and a condensing unit. These are essentially the factory assembled self-contained units and are also known as local systems.

## **SPLIT SYSTEMS**

As the name suggests, the split systems are individual systems in which the two heat exchangers are separated (one outside, one inside). The indoor unit (evaporator) consists of a direct expansion (DX) cooling coil, filter and fan whereas the outdoor unit (condensing unit) contains one or more reciprocating/rotary compressors, a condenser and a fan. The evaporator and the condensing unit are connected by refrigerant piping.

### **System description**

Split system air-conditioning units comprise internal and external units linked by refrigerant pipework. The refrigerant compressor, installed in the outdoor unit, pumps the refrigerant through the indoor unit and the outdoor unit arranged in a closed loop. The refrigerant picks the heat from the indoor unit (evaporator coil), and rejects energy to the outside atmosphere as it goes through the outdoor unit (condensing coil). Energy rejected is the sum of the energy taken indoors plus the energy consumed by the compressor in pumping the refrigerant through the refrigerant circuit.

The indoor unit fan pulls or pushes air around the outer surfaces of the coil inside the indoor unit, taking warm air from the room and injecting cooled air into the room in summer. The air passing through the indoor unit is cooled; say to 60°F, before being re-circulated back to the room.

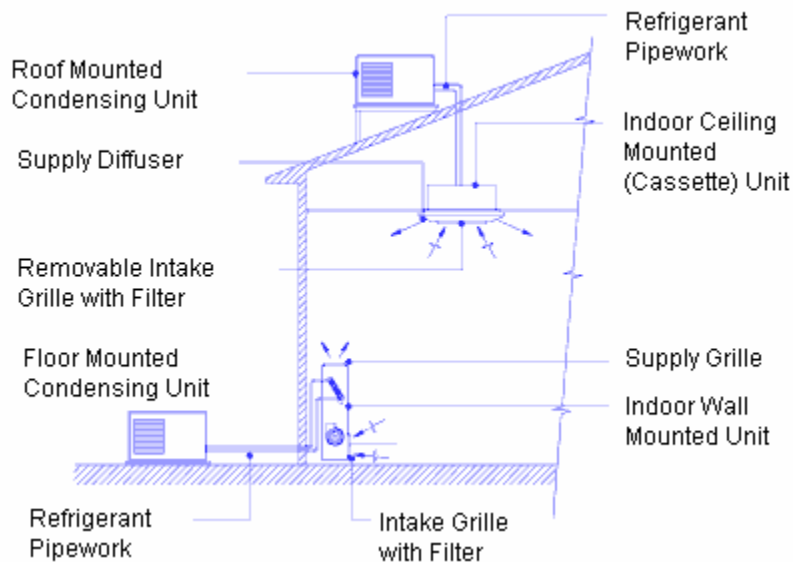

### **Split system air-conditioning units**

Indoor units can be wall mounted or ceiling mounted. Recessed ceiling mounted units are often referred to as "cassette" type units. Refrigeration pipework will comprise liquid and gas pipelines, of unequal sizes, and may be restricted in length, requiring careful location of the indoor and outdoor units for larger buildings. The outdoor unit can be roof mounted, wall mounted or fixed directly to the ground.

Split unit is a choice in applications, which require interior zone cooling. Remember, a window unit requires outside exposure for heat rejection and cannot be used for interior rooms.

#### **Controls configurations**

Split system air-conditioning units provide good individualized control. A hand held remote controller is often provided, linked to a wall unit with thermostat temperature control. The fan of the indoor unit may have two or three speeds to give some modulation of heat or cooling output. The split system may be reversible, operating as a heat pump to provide heating to the space. Alternatively an electric heating element is used to provide heating.

With the temperature sensor located in the space the heating or cooling provided by the fan-coil unit can be tempered according to the needs of the individual space.

#### **Maintenance and balancing considerations**

Split system air-conditioning units are free-standing and independent and thus balancing is not an issue. Maintenance to the units is required to ensure that their operation is satisfactory and that lifespan is maximized. The air filter on the intake grille will require cleaning, according to the quality of the environment and the frequency of use of the units.

The use of split systems for large areas can cause excessive maintenance costs due to the large number of moving parts - each split system has its own compressor and a sealed refrigerant system.

## **WINDOW UNITS**

Window-mounted air conditioners cool the individual conditioned spaces. A window unit is an encased assembly designed primarily for mounting in a window, through a wall, or as a console. These units are designed for comfort cooling and to provide delivery of conditioned air to a room without ducts. They include a prime source of refrigeration, dehumidification, means for circulating and cleaning air, and may also include means for ventilating, and/or exhausting and heating.

They are cheap and easy to install, being fitted into windows or through walls. They are quite common in small, mid-grade suburban office space, older institutional buildings and accommodation blocks.

They have a low initial cost and are quick and easy to install.

### **System description**

Window units are simple refrigerate coolers packaged into a single box that produces cool air on one side and rejects hot air on the other. These require outside exposure for heat rejection and cannot be used for interior rooms. Split unit option shall be used in such places. The refrigerant compressor now is part of the machine located at the window area. Since this compressor gives out most noise, among other components, the window unit will make the room acoustically inferior to other air conditioning systems.



### **Controls configuration**

The controls for window units are simple and inbuilt, with a rotating switch marked with a hot-cold scale with no temperature settings. Most units will heat as well as cool. Fresh air control, if it exists, is normally adjusted by a manual lever. Fresh air exchange for the room can be provided by: -

- Setting the “ventilator” switch of the window air conditioner to “open” position
- Installing a ventilating extract fan in the room to extract room air to outside – caution- not to oversize the fan
- Naturally leaking of air in and out of the room

### **Maintenance and balancing considerations**

Window units are often poorly maintained. They are not an engineered solution to air-conditioning needs, but are often used where air-conditioning is either an afterthought or not intended for regular or long term use. The units require regular servicing of the refrigeration system on a regular basis to operate, and the cleaning of filters. The manual levers for fresh air-control sometimes become casualties to age and rough handling, which can cause unwanted fresh air flow. There are no balancing considerations for this system.

### **HEAT PUMPS**

A cooling only system cools the indoor air but a heat pump provides cooling in summer season and heating in winter season.

A DX system operating in reverse vapor compression cycle is classified as a Heat pump. Through the addition of a special four-way reversing valve, heat flow in a mechanical refrigeration loop can be reversed so that heat is extracted from outside air and rejected into the building. Such a facility is required during the winter season to heat the indoor using the same physical components. Due to added heat of compression, the efficiency of a heat pump is higher compared to the cooling cycle. A supplementary electric resistance heater may also be used to assist the heat pump at lower outdoor temperatures. In colder climates, heat pumps require a defrost period. During defrost times the electric heater is the only means of heating the interior of the building. These units come as split or packaged systems.

Heat pumps for air conditioning service may be further classified as:

#### **Air-to-Air Heat Pumps**

The air-to-air heat pump is the most common type of heat pump. It is particularly suitable for factory-built unitary heat pumps, and has been widely used for residential and commercial application. Air is used as the heat source and heat sink. Extended surface, forced convection heat transfer coils are normally employed to transfer the heat between the air and the refrigerant. When selecting or designing an air-source heat pump, two factors in particular must be taken into consideration:

1. The variation in temperature experienced in a given locality.
2. The formation of frost

### **Water-source Heat Pumps**

The water-source heat pump uses water and air as the heat source or heat sink depending on the mode of operation. When cooling, water is used as the heat sink, and the heat pump operates as a water-cooled air conditioner. When heating, water is used as the heat source and the equipment operates as a water chiller.

The water-source heat pump is suitable for many types of multi-room buildings, including office buildings, hotels, schools, apartment buildings, manufacturing facilities and hospitals.

### **Advantages**

1. Affords opportunity for energy conservation by recovering heat from interior zones and/or waste heat and by storing excess heat from daytime cooling for night time heating
2. No wall openings required.
3. Longer expected life than air-cooled heat pumps.
4. Lower noise level because condenser fans are eliminated.
5. Energy for the heat pumps can be metered directly to each tenant.
6. Total life cycle cost frequently compares favorably to central systems when considering relative installed cost, operating costs, and system life.

### **Disadvantages**

1. Space required for boiler, heat exchanger, pumps and heat rejecter.
2. Higher initial cost than for most other multiple-packaged unit systems.
3. Reduced airflow can cause the heat pump to cycle cutout. Good filter maintenance is imperative.

## **SECTION-2**

## **HVAC SYSTEM COMPONENTS**

A heating, ventilation and air-conditioning (HVAC) system may be defined as an assembly of components with a particular structure and a defined function. There are countless ways in which basic HVAC components may be assembled into systems. In the following pages we review the operation and use of a range of components.

### **Chillers**

Chillers are a key component of most centralized air-conditioning systems. The function of a chiller is to generate chilled water, which is distributed to large spaces for cooling. The two principal types of chiller are air-cooled and water cooled. Compared to water, air is a poor conductor of heat and therefore air-cooled chillers are larger and less efficient. The typical condensing temperature for an air-cooled chiller is 120°F as opposed to 105°F in a comparable water condensed chiller. Air-cooled chillers also operate at higher compressor ratios – which mean less cooling per watt energy consumption.

Air cooled chillers are generally located outside the building and reject heat directly to the atmosphere, while water cooled chillers are generally located within the building and use cooling towers located outside the building to reject the heat.

### **Circumstances favoring Air-cooled Systems**

Air cooled chillers are favored over the water cooled systems under following circumstances:

1. Where water is scarce or quality water is not available
2. Where the system is not required to operate 24 hours.
3. Where the system is not to be located in or around noise restricted areas
4. Where there is adequate and accessible roof top or ground space for the system equipment
5. Where siting of cooling tower is restricted due to Legionella risk minimization constraints.
6. Where air-conditioning requirement is less than 200 TR
7. Where statutory requirements for health and safety may not permit use of cooling towers in certain areas.
8. Where a high humidity climatic condition in tropical areas exists that significantly reduces the effectiveness of cooling towers.

### **Circumstances favoring Water-cooled Systems**

Water-cooled chillers are generally favorable over the air-cooled systems under the following circumstances:

1. Where the system is required to operate 24 hours.

2. Where there is limited roof top or ground space for the system equipment
3. Where noise minimization and aesthetics are of relative importance
4. Where there are larger system capacity requirements, typically above 200 TR.

The present trend leans towards the use of air-cooled condensers. Results from recent generic studies on comparative life cycle costs of air cooled and water cooled systems indicate that each system is considered to be more favorable than the other over a certain range of plant capacity. As a guide, conclusions could be generalized and summarized as follows:

Capacity Range (TR)	Favorable System
40 to 200	Air-cooled chilled water system (explore the pros and cons of using multiple DX systems if possible)
200 and above	Water-cooled chilled water system

### **Chiller Types**

Different types of chiller are also used depending upon the type of compressor used as part of the refrigeration circuit. The different types of compressors are as follows:

#### **1. Reciprocating:**

Reciprocating compressors are categorized as positive displacement machines. These are available in two basic types: hermetically sealed units and units of open construction. In hermetically sealed units, the motor and the compressor are direct-coupled and housed in a single casing that is sealed to the atmosphere. In open construction units, the motor and the compressor are in separate housings. In general, open construction units have a longer service life, lower maintenance requirements and higher operating efficiencies. The hermetically sealed units are most common particularly in small capacities. Single stage reciprocating machines have an ability to operate at compression ratios of 10 to 12.

The capacity control in a reciprocating machine is achieved through 'On-Off' or 'Loading- Unloading' of compressor cylinders.

Reciprocating machines are manufactured in capacities from 0.5 to 150 TR.

The main factor favoring reciprocating machines is low cost. The other advantage is that multiple reciprocating machines can be installed to closely match the building loads. Multiple units allow flexibility to operate machines per the need. If properly managed this could contribute to significant energy savings during low loads.

A major drawback is a high level of maintenance requirements, noise and vibration. Since the capacity is limited to 150 TR, multiple units cost more than other options. Multiple chiller configurations require large space and consume more energy per ton of refrigeration.

## 2. **Rotary Screw:**

Rotary or screw chillers, like reciprocating machines are positive displacement compressors. Rotary is a wider term that may include vane, eccentric, gear or screw types. The commercial refrigeration installation relies more on screw machines. Screw compressors are available in several designs, both single screw and twin screw, with oil-free and oil-injected designs in both types. Twin-screw oil-injected compressors are slightly more energy efficient at moderate compression ratios. Twin-screw compressors have an ability to operate at a compression ratio of 30. Units are available in both hermetically sealed and open construction.

Screw compressors are used in the mid-range of unit sizes, around 20-1000 tons. They are compact and have less moving parts, hence lower maintenance costs and longer life spans. Continuously variable loading can also be provided, improving partial load efficiencies.

The capacity control in a screw compressor is achieved through a moveable slide stop valve, which will vary the compressor internal volume ratio to achieve optimum energy consumption during part load operation.

The major drawback is their high cost. For smaller loads, reciprocating machines are less expensive to purchase and for large loads centrifugal machines cost less.

## 3. **Rotary Scroll:**

Scroll compressors have been used in commercial practice for systems that have capacities less than 30 TR. Scroll compressors are used in smaller units such as unitary heat pumps, and may be up to 10% more efficient than an equivalently sized reciprocating unit. On such small sizes, these do not affect the life cycle economics drastically.

## 4. **Centrifugal:**

Centrifugal chillers are categorized as variable volume displacement units. Like reciprocating machines these are also available in both hermetically sealed and open construction. Commercially the hermetically sealed units are more widely used, despite their lower operating efficiency. Centrifugal chillers for refrigeration applications are generally designed for a fixed compression ratio of 18.

The capacity control is achieved through the use of inlet vanes on the impellers that restrict refrigerant flow.

The centrifugal chillers are manufactured in capacities from 90 to 2000 tons and are generally used for capacities above 200 tons.

The main factor favoring centrifugal machines is their high operational efficiency at full load, compact size and availability in large sizes. The biggest drawback of centrifugal machines is a very poor part load performance and inability to operate at low cooling loads. At extreme low loads, these chillers are prone to a condition known as surging.

### Measuring Chiller Efficiency

Chiller efficiency is measured in terms of a "Coefficient of Performance" rather than a percentage efficiency. This is because one unit of electricity supplied to a chiller will produce two to three units of cooling, and an efficiency of 200-300% sounds odd. A chiller that produces three units of cooling to one unit of electricity is said to have a "coefficient of performance" or "COP" of three.

### Circuit Arrangements

The following examples of chiller water circuit arrangements are included to indicate how chillers are used to meet building cooling loads.

1. Air cooled chillers
2. Water cooled chillers, open circuit cooling tower
3. Water cooled chillers, closed circuit cooling tower
4. Air cooled chiller, ice storage option
5. Air cooled chiller, free cooling option

#### Air-cooled chillers

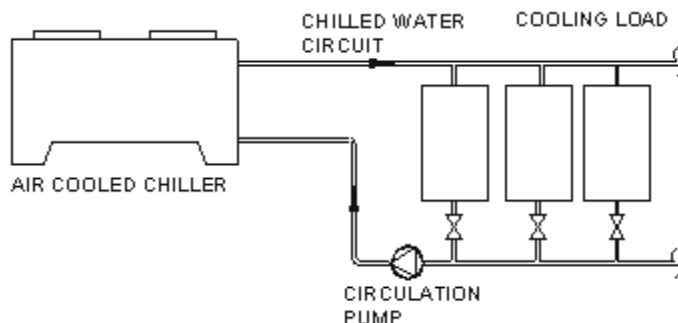

#### Air cooled chillers

Air-cooled chillers are effectively a single package system, into which chilled water is directly plumbed.

Note that centrifugal chillers require water-cooled condensers. An air-cooled condenser is not a recommended option for the centrifugal machines operating at low-pressure refrigerants. The screw and reciprocating machines are available in both air-cooled and water-cooled condenser options.

**Water cooled chiller - open circuit Cooling Tower**

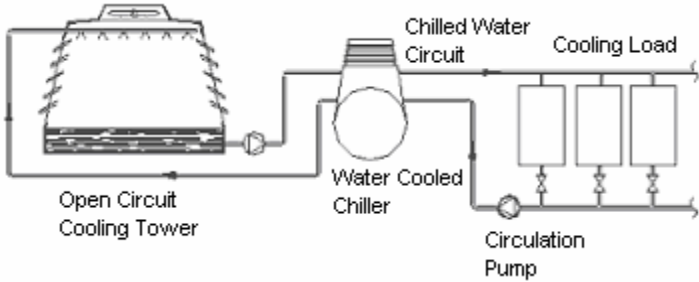

**Water cooled chiller, open circuit cooling tower**

Water cooled chillers have a separate flow of water passing through the condenser, typically at around 20-30°C. This is then passed through a cooling tower. In an open circuit cooling tower, the condenser water is directly cooled by spraying it onto large sheets called media. and passing air through the media.

**Water cooled chiller - closed circuit Cooling Tower**

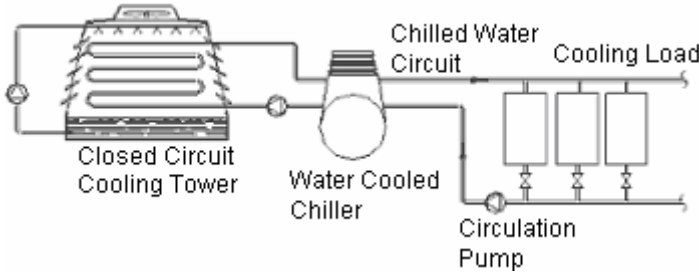

**Water Cooled Chiller, Closed Circuit Cooling Tower**

A closed circuit cooling tower has its own flow of water that is sprayed onto the condenser water circuit pipes to cool them down indirectly.

**Ice storage option**

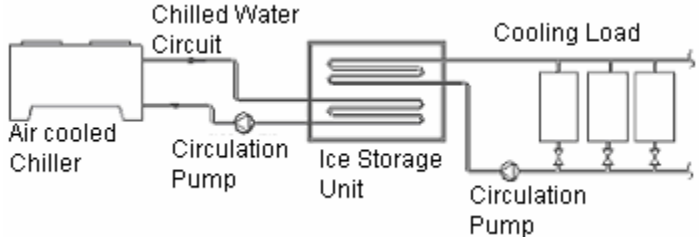

**Air cooled chiller, ice storage option**

Ice storage may be used to reduce chiller size for variable cooling load profiles or to take advantage of night electricity rates. Ice storage systems can use water cooled or air cooled chillers.

## Free cooling option

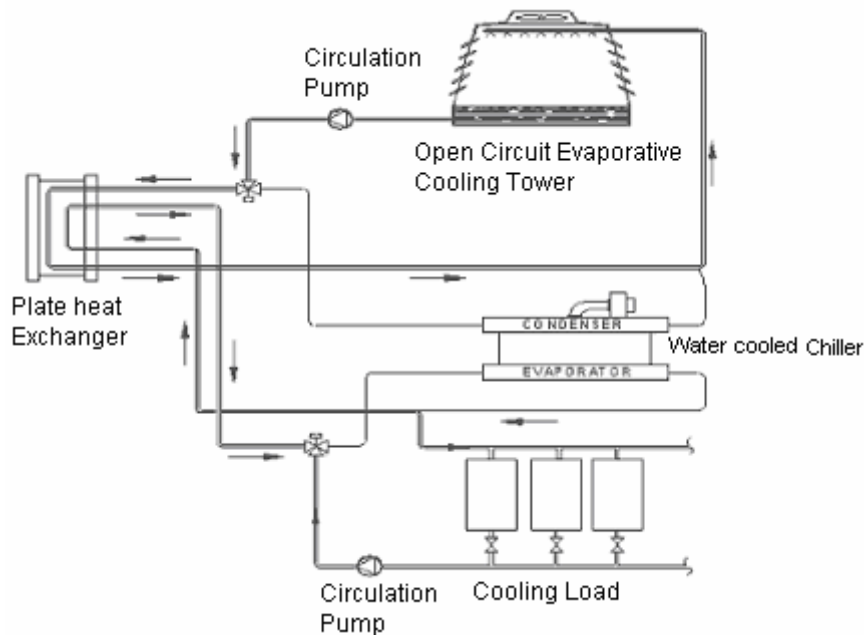

**Air Cooled Chiller, Free Cooling Option**

During certain conditions it may be possible to provide cooling without the operation of a chiller, using water circulated directly through the cooling tower.

### **Energy Efficiency Opportunities**

There are a number of opportunities to improve energy efficiency with chiller systems. Here are some of the best.

1. **Chiller Sequencing** - In general, chillers are installed in groups, which allow the number of chillers operating to be adjusted to meet the load. This is important because the efficiency of chillers decreases as the load gets smaller - running a 500kW chiller on 50kW load will waste a lot of energy. The adjustment of chiller staging can produce significant performance benefits.

For applications where cooling is required for critical service delivery, the relevant areas need to be classified as essential. For essential services, continuity of supply is critical; therefore the provision of cooling cannot be relied on a single chiller. One back up unit would be required. The provision of 1 additional back up unit is known as N+1 strategy. This strategy involves the provision of one more unit than the quantity required for the normal system operations. For example if the total capacity requirement is 1500 TR, 2 units each of 750 TR should be provided instead of one unit of 1500TR if the essential load is less than 50% of the total load. Otherwise 2 units having the capacity equal to the essential load shall be required. A life cycle cost economics of using 3 X 50% option could also be investigated.

2. **Operating Temperatures** - The wider the temperature difference between the condenser and evaporator of the chiller (the hot and cold sides, respectively), the poorer the efficiency. Thus if you can raise the chiller water temperature for some of the year and decrease the condenser water temperature for some of the year, this will improve efficiency.

3. **Operational regimes:** It is imperative to determine which portion of the total load requires 24 hours operations. Say in an office building operating for 10 hours a day and the data center room requires 24 hrs operations, it shall be prudent to use multiple chillers with capacity matching nearly the critical essential load for overall economics.

It would be more cost efficient to operate a smaller capacity chiller at full load than a bigger capacity at part load.

4. **Suction pressure:** While designing a refrigeration system, a specific suction pressure is usually specified, and oftentimes designers forget that this may change dramatically. Lower suction pressure signifies lower evaporator temperature, which is the refrigerant temperature required to absorb heat from the medium being cooled. Lowering the evaporator temperature 10 deg from a base of 40°F and 105°F reduces the capacity about 24%, and at the same time increases the compressor HP per ton about 18%. The twin-screw compressor allows it to handle large variations in suction pressures with small changes in operation efficiency. A reciprocating compressor can also accommodate variations. With the centrifugal compressor, there is little potential variation available and even a small variation can cause considerable problems. In simple words the screw and reciprocating machines can meet additional capacity requirements caused due to expansion or modification just by control settings.

5. **Discharge Pressure:** Higher discharge pressure signifies higher condensing temperature, which is the refrigerant temperature required to reject heat to the condensing medium. Increasing the condensing temperature 15 deg from a base of 40° F and 105°F reduces the capacity about 13% and increases the compressor HP per ton about 27%. Discharge pressure is of considerable importance in refrigeration systems, particularly in the water-cooled condenser. The lower the temperature of discharge gas, the less fouling within the condenser. In screw compressors, the discharge temperature of refrigerant gas is held to a minimum due to the lubricant cooling system. The highest system pressure occurs in a reciprocating compressor while in a centrifugal compressor it is kept low due to inter-stage cooling.

**6. Cooling load profiling:**

- Peak load demand determines the overall capacity of the system. The total chiller capacity in tons of refrigeration shall match or exceed the peak building load.
- Part load requirements determine the number and size of chillers required. Cooling load profile will help to determine the type of chiller to use and if single or multiple chillers should be installed. Multiple chiller installations allow facilities professionals to stage their operation to match building loads while keeping the chillers operating at energy efficient loading. With high capacity centrifugal

chillers, part load applications should not be less than 20 to 35% of the full load capacity. If the part load requirement is less than this amount, a reduced capacity chiller should be selected.

- Essential service requirements determine the system reliability requirements. Say in a hospital, the Operation Theater or infectious area calls for a controlled environment all the time. Therefore the selection of chiller should take into account a dedicated chiller capacity to meet the essential loads.
7. **Cooling Tower Sequencing** - Chillers are normally attached to a bank of cooling towers. As the chiller load varies, so does the need for cooling towers. Adjusting the sequence of cooling tower operation can save energy.
  8. **Chiller Heat Recovery** - If your building has a need for hot water, you can recover approximately 10% of the heat rejection from a chiller as hot water at 140-160°F. This can avoid unnecessary boiler operation, and thus save energy. The remainder of the heat is only available at 85° F or less and this is little use for anything other than perhaps swimming pool heating.
  9. **Materials (Refrigerant)**: Use environment- preferred products that shall be available for the life cycle of the plant, for instance a non-CFC type refrigerant should be used.

All the above chiller machines are available with non-CFC refrigerant options but the new generation scroll and screw machines have been specifically developed for use with R-134a refrigerant, which is a most popular refrigerant today. To date, the reciprocating compressors available have been converted to R-134a use from original R-22 designs. No authentic data is available on the capacity de-rating/enhanced performance of reciprocating machines with R-134a refrigerant. This should be investigated, should a reciprocating chiller machine be considered.

## COOLING TOWERS

Water cooled chillers require a source of cooling water, such as cooling tower water, to extract heat from the refrigerant at the condenser and reject it to the ambient environment. Cooling Towers for HVAC duty are usually described by their tons of cooling capacity. The cooling capacity indicates the rate at which the cooling tower can transfer heat. One ton of cooling is equal to 12,000 BTUs (British thermal units) per hour, or 200 BTUs per minute. The heat rejected from an air conditioning system equals about 1.25 times the net refrigeration effect. Therefore the *equivalent ton* on the cooling tower side actually rejects about 15,000 Btu/hour (12000 Btu cooling load plus 3000 Btu's per ton for work of compression). Cooling tower capacities at commercial, industrial, or institutional facilities typically range from as little as 50 tons to as much as 1,000 tons or more. Large facilities may be equipped with several large cooling towers.

The controlling principle of a tower system is water's inherent nature to lower its own temperature as it evaporates. By evaporating a small part of the process water, the temperature of all process water is lowered.

Tower cells accomplish this by spraying fine water droplets in a contained environment. The droplets fall through a stream of upwardly moving air. The more contact time of the air and water, the greater the amount of evaporative and heat transfer. To significantly increase the amount of contact time, cells include "fill" material to reduce the free falling of water and enlarge the surface area of water to air. The result is greater exposure of water to air. With an increase in exposure, there is a corresponding increase in cooling capacity.

Air must absorb water for evaporation to occur. The higher the level of humidity, the less air is able to absorb water and, as a result, the less efficient the tower system in cooling. Typically, cooling tower systems capacity are rated to lower 95°F water to 85°F at 78°F *wet bulb*. Wet-bulb temperature of the air is the lowest temperature possible for evaporation due to ambient or surrounding environment so the temperature of the water cannot drop below the prevailing wet bulb temperature of the air.

Each tower system must be specifically sized for each geographic area's prevailing summer wet bulb temperature. While some geographic areas may experience cold climates, a tower's cooling capability is usually set at no colder than 70°F during winter months. High efficiency mechanical draft towers cool the water to within 5 or 6°F of the wet-bulb temperature, while natural draft towers cool within 10 to 12°F.

### **Types of Cooling Towers**

There are three basic types of towers.

1. **Forced Draft Tower** - In forced draft cooling towers, air is "pushed" through the tower from an inlet to an exhaust. A forced draft mechanical draft tower is a blow-through arrangement, where a blower type fan at the intake forces air through the tower. A forced draft tower has a sensor that monitors the process water temperature after it exits from the tower. The fan engages or disengages when the process water temperature rises either above or below the desired set point.
2. **Induced Draft Tower** - A second type of tower, induced draft has a fan in the wet air stream to draw air through the fill. Induced draft cooling towers are characterized as Cross-flow and Counter-flow designs, by virtue of air-to-water flow arrangement. The difference lies in the FILL arrangement. In a counter-flow induced draft cooling tower, air travels upward through the fill or tube bundles, opposite to the downward motion of the water. In cross-flow induced draft cooling towers, air moves horizontally through the fill as the water moves downward. An induced draft mechanical draft tower is a draw-through arrangement, where a fan located at the discharge end pulls air through the tower.
3. **Natural Draft Tower** - A third type, natural draft tower, has no mechanical means to create airflow. Natural-draft cooling towers use the buoyancy of the exhaust air rising in a tall chimney to provide the draft. Warm, moist air naturally rises due to the density differential to the dry, cooler outside air.

In all types, towers use the force of gravity to drain water into a sump from which the pump delivers the water to the chiller condenser where it picks up heat of the refrigerant. The now-warmed water continues to flow back to the outdoor tower through return lines. The cycle continuously repeats.

## **BOILERS**

The production of heat is a relatively straightforward affair. Typically, all a boiler does is burn fuel and produce heat. This heat is absorbed by water, which flows through tubes inside the boiler.

Gas boilers are the most common type in buildings HVAC, although occasionally you will find electric boilers or oil boilers. You can also sometimes find dual fuel boilers, typically able to use gas or oil.

Most boilers operating in buildings produce hot water in the region of 70-85°C for the purpose of providing a heat source for the air-conditioning system. These boilers may also serve the domestic hot water systems, but these are more often served by separate hot water cylinders.

### **Boiler Types**

The common type of boilers for HVAC installations include:

1. **Cast Iron Boilers** - These boilers range up to 10 million Btu/h and are most typically used in residential or light commercial heating applications and can be retrofitted with a domestic heat coil for domestic hot water use. For heavier commercial use several of these boilers can be set up on a manifold piping system and offer step-up sequencing to meet higher demands when needed. Cast iron boilers can provide either steam or hot water heat in low pressure applications. Combustion efficiencies range from 75% to 93% depending on whether it is steam or hot water and combustion controls, flue dampers, sequencing of multi-stage set-ups, frequency of tune-ups and/or air and/or water pre-heaters (economizers).
2. **Water Tube Boilers** - From 10 million BTU/h up to 300 million Btu/h, these boilers are generally found in medium to large commercial/industrial use and can be either steam or hot water in low to high pressure applications. They can be either oil, coal, or gas fired. This type of boiler passes hot flue gases around tubes filled with water. Combustion efficiencies vary depending on several factors including: whether it is steam or hot water, combustion controls, flue dampers, frequency of tune-ups and/or air and/or water pre-heaters (economizers).
3. **Fire Tube Boilers** - from .6 million BTU/h up to 50 million BTU/h these boilers use hot flue gases passing through tubes submerged in water generally found in medium to large commercial/industrial use and can be either steam or hot water in low to medium pressure applications. Again as with the water tube boiler combustion efficiencies depend on several factors as noted above.

One other type of boiler not mentioned above is the **electric boiler**. One could say that an electric hot water heater is an electric boiler although there are electric boilers that can heat water to steam temperatures.

### **Boiler Efficiency Measurement**

When we talk about boiler efficiency we talk about two related types of efficiencies and both can have an impact on the energy budget. There is boiler efficiency and there is combustion efficiency. A decrease in combustion efficiency will decrease boiler efficiency but not necessarily vice versa.

1. **Combustion Efficiency** assesses the efficiency with which the fuel is being burned, and is a good measure of the tuning of a boiler. It is measured by dividing the usable heat produced by the fuel input in BTU/h content. This calculation is based on the actual heat available produced by the system after heat loss up the stack and other heat losses which do not provide usable heat. Excess air is partially responsible for the heat loss but it is necessary to complete the combustion process. Therefore it is important that the burner system is tuned and monitored on a regular basis. Using combustion analyzers the O<sub>2</sub> and stack temperatures can be monitored for spikes which will alarm the maintenance crew about possible problems. It is important to maintain good combustion efficiency for overall boiler efficiency.
2. **Boiler Efficiency** assesses the ratio of heat out to fuel in, and is the best overall measure of boiler operation, accounting for boiler load variation. It is measured by dividing combustion losses, radiant heat losses from the boiler jacket and near boiler piping, and unknown losses (losses from tube scaling, soot build-up (exchanger thermal efficiencies)) by total fuel input in BTU/h. Much of boiler efficiency is determined by combustion efficiency and a lot of maintenance departments focus on combustion efficiencies and ignore the other losses.
3. **Thermal Efficiency** is related to how efficient the heat exchanger is working. Things like soot build-up or water scaling can reduce the efficiency of a boiler.
4. **Steady-State Efficiency** is the efficiency of the boiler running full blast under maximum load.
5. **Overall Seasonal Efficiency** is important to track to see if there is an annual degradation in efficiency. It gives you the big picture from year to year for comparison.

To get the most out of your boiler system it is necessary to implement a complete plan to maintain every aspect of boiler efficiency. Providing that a boiler maintenance/efficiency plan is put into place and qualified boiler technicians perform the boiler tuning with the appropriate tools, a cost savings in energy use can be realized.

### **Energy Efficiency Opportunities**

There are several major energy efficiency opportunities for boilers:

1. **Boiler sizing** It is relatively common practice in building design to oversize the boilers. However, the efficiency of a boiler drops as the loading decreases, although above 50% loading most boilers will still perform reasonably well. Below 25% loading major energy savings may be possible by installing another, smaller boiler.
2. **Boiler sequencing** Linked to the issue of sizing is the issue of sequencing of multiple boilers sets. The ideal sequence minimizes the number of boilers working at part load and maximizes the load on all boilers to get the best efficiency result.

3. **Boiler control tuning** The control of boilers in terms of the amount of air provided for combustion is critical to the efficiency of the boiler.

## **AIR HANDLING UNITS**

An air handling system is a means of providing conditioned air to the space in order to maintain the environmental requirements. While there is no "one correct way" to design an air handling system, all air handling systems have basic components that are used. To meet the whole sensible and latent cooling needs of a space with the cool air they supply, these systems use air handling units and, in most cases, chilled water coils to supply cooled and dehumidified air to the space. These systems may use low-, medium-, or high-pressure air distribution systems. All air systems are subdivided into single -zone, multizone, dual-duct, reheat, and variable air volume systems.

1. **Single-zone systems** - Single-zone systems serve just one temperature control zone and in most cases, these are controlled by varying the quantity of chilled water or refrigerant, adding reheat, adjusting face or bypass dampers, or a combination of these.
2. **Multizone systems** - Multizone systems are used to serve a small number of zones with just one central air handling unit. The air handling unit for multizone systems is made up of heating and cooling coils in parallel to get a hot deck and a cold deck. For the lowest energy use, hot and cold deck temperatures are, as a rule, automatically changed to meet the maximum zone heating (hot deck) and cooling (cold deck) needs. Zone thermostats control mixing dampers to give each zone the right supply temperature. Not much in use in modern air-conditioning systems.
3. **Dual-duct systems** - Dual-duct systems are much like multizone systems, but instead of mixing the hot and cold air at the air handling unit, the hot and cold air are both brought by ducts to each zone where they are then mixed to meet the needs of the zone. It is common for dual-duct systems to use high-pressure air distribution systems with the pressure reduced in the mixing box at each zone. Not much in use in modern air-conditioning systems.
4. **Reheat systems** - Reheat systems supply cool air from a central air handler as required to meet the maximum cooling load in each zone. Each zone has a heater in its duct that reheats the supply air as needed to maintain space temperatures. Reheat systems are quite energy-inefficient and have become rare in new buildings.
5. **Variable air volume systems** – Variable air volume systems control the temperature in a space by varying the volume of supply air rather than varying the supply air temperature. Zone airflow is modulated by individual variable air volume (VAV) boxes serving respective zones whereas total system airflow is varied by the use of inlet vanes, discharge dampers, speed control, and variable pitch blades. This is the most common system in commercial office buildings.

## **Air handling system major components**

Air handling units may consist of a supply fan and coil section with a chilled water or direct expansion coil, preheat or reheat coil, heating coil section, filter section, mixing box, or combination mixing box filter section. In some larger units, a return fan may be added to the unit. Air handling units are configured to be either blow-through or draw-through units. A blow-through unit is when one of the coil sections is located downstream of the supply fan. A draw-through unit is when one of the coil sections is located upstream of the supply fan. Draw-through units can be further configured to be either horizontal units or vertical units.

Air handling systems are comprised of the following major components.

### **COOLING & HEATING COILS**

Cooling & heating coils for air-conditioning applications consist of aluminum finned copper tubes. The fins increase the surface area and thus improve heat transfer. Low temperature hot water or chilled cold water is circulated through the tubes of the coils to provide the energy source for heat transfer. Control is achieved via the use of 2 or 3 port motorized control valves. The valves control the amount of water flowing into each coil, dependant upon the temperature demand. In some cases, cooling coils will use refrigerant directly rather than having chilled water as an intermediate fluid.

1. **Chilled water coils** - Fin coils generally consist of rows of round tubes or pipes that may be staggered or placed in-line with respect to the airflow. The inside surface of the tubes is usually smooth and plain, but some designs have various forms of internal fins or turbulence devices (turbulators) to improve performance. The individual tubes in a coil are usually interconnected by return bends (U-bends) to form the serpentine arrangement of multi-pass tube circuits. Chilled water coils usually have aluminum fins and copper tubes, although copper fins on copper tubes are also used.
2. **Hot water coils** - Hot water coils are basically the same as described for chilled water coils. However, the most common circuiting arrangement is often called single -row serpentine or standard circuiting. With this arrangement, all tubes in each coil row are supplied with an equal amount of water through a manifold, commonly called the coil header.
3. **Direct expansion coils** - Coils for refrigerants present more complex cooling fluid distribution problems than water coils. The fin coil that is used for evaporators in most air handling units is typically constructed from copper tubes with aluminum fins. Fin spacing is generally from 6 to 14 fins per inch (2 to 4 mm). Most manufacturers offer a wide choice of fin space and a number of tube rows, usually two to eight in a single casing. The whole tube and fin assembly is enclosed in a galvanized steel casing.
4. **Steam coils** - Coils generally consist of a steam header and a condensate header joined by finned tubes. The headers may be both at a side of the unit, with U-bends between them, or sometimes an internal steam tube is used to carry the steam to the remote end of an outer finned tube. Vertical headers may be used with horizontal finned tubes, or sometimes horizontal headers at the bottom of the unit supply vertical finned tubes. Copper and aluminum are the materials most commonly used in

the fabrication of low-pressure steam coils. Low-pressure steam coils are usually designed to operate up to 150 to 200 psig (1.0 to 1.4 MPa). For pressures higher than 200 psig, tube materials such as red brass, Admiralty, or Cupro-Nickel are used. Tubing made of steel or various copper alloys, such as Cupro-Nickel, are used in applications where corrosive materials or chemicals might attack the coils from either inside or outside.

## DEHUMIDIFIERS

A dehumidification system is one that takes the water vapor from the air. It may do this by cooling the air below its dew point or by chemical means. Two most common means for dehumidification equipment are refrigerant based and desiccant based dehumidifiers.

1. **Refrigerant Based Dehumidifiers** – Cooling coils can be used to provide dehumidification of the supply air by the reduction of air temperature below the dew-point, forming condensation, and thus reducing the moisture content of the air. The refrigeration type of dehumidifier is the most commonly used system. The refrigerated system has its limitations. The coil temperature can only be cooled to the point where the moisture on the coil does not freeze. If the refrigerated system cannot remove enough moisture from the air, other dehumidifiers, such as solid-state absorbents, are typically used.
2. **Desiccant Based Adsorbents** – Desiccant based dehumidifiers are those which have the ability to make moisture cling to their surface. The products that are used the most are silica gel, activated alumina, and molecular sieve. These desiccant materials will take the water vapor from air or gas with physical or chemical change. The water vapor that they pick up can be released by passing hot dry air across the surface of the product. These products have submicroscopic cavities that hold the particles of adsorbed water vapor.

## HUMIDIFIERS

Steam humidifiers are generally used for central air handling systems. But, in order to ensure the advantages of steam humidifiers over other humidifiers, steam humidifiers must provide three performance characteristics: conditioning, control, and distribution. The humidifier must condition the steam to be completely dry and free of significant matter. It must respond immediately to control, provide precise output, and distribute steam as uniformly as possible into the air. Failure of the humidifier to provide these characteristics will result in improper humidification.

## SUPPLY & EXTRACT FANS

Fans are used to provide air circulation and move other gases or vapors out of the building. There are two common forms of fans: centrifugal fans and axial fans. Centrifugal fans are able to move more air at higher pressures and with less noise than axial fans. Axial flow fans are used when higher air volumes at lower pressure resistances are required. In general, centrifugal fans would be used for a ducted system, for either supply or extract air flows, where a number of grilles are served by a common ventilation system. Axial flow fans would be used for point of use ventilation systems such as localized extract fans.

All fans have three basic parts: an impeller, motor, and housing. The impeller is the part of the fan that moves the air. In order for an impeller to move air, it must rotate. This is done by power from the motor. Housings are made to fit the individual fan types. Materials used in fan construction are generally steel. They are also built of aluminum and can be made of special materials, such as stainless steel or epoxy-bound fiberglass. Fans can be coated with compounds that are especially suited to the many kinds of corrosive atmospheres in which they must work. In some cases, spark-proof construction is required.

### **Centrifugal Fan**

A centrifugal fan is built with a wheel that is mounted on a horizontal shaft and turns in a housing. Air enters near the axis of the wheel and is discharged through the housing outlet. Air may enter the fan wheel at one or at both ends of the wheel's axis. The fans that are in use for air-conditioning, heating, and ventilating systems normally do not exceed 10 inches of water (2,488 Pa) static pressure. The main feature that distinguishes one type of centrifugal fan from another is the curvature and the inclination (slope) of the fan wheel blades. The slope largely determines the operating characteristics of the fan. The three principal types of blades are the forward-curved blade, the radial blade, and the backward inclined blade.

1. **Forward Curved Fan** - The forward-curved blade fans are used primarily for low-pressure heating, ventilating, and air-conditioning applications. Domestic furnaces, low-pressure central station air handling units, and packaged air-conditioning units, such as window and rooftop air-conditioning units, use this type of fan.
2. **Radial Fan** - In the radial blade fan wheel, the tip of the blade projects straight out from the fan shaft. The radial blade fan can work at a higher pressure than either the forward-curved or the backward-inclined blade fans. However, to move the same amount of air as the other two types, the radial fan wheel requires more horsepower. Due to its low efficiency, the radial blade fan generally is not found in heating, ventilating, and air-conditioning (HVAC) applications. It is used more for material handling applications, since the wheels are of simple construction and they can be fixed in the field.
3. **Backward Curved** - In the backward-inclined blade fan wheel, the tip of the blade is inclined backwards away from the direction of the rotation of the fan wheel. This lets the backward-inclined fan move air at higher pressures than the forward-curved fan. It is more efficient (uses less horsepower) for many air volumes and pressure ranges than the forward-curved blade fan. The backward-inclined blade wheel is also built with blades that are made in an airfoil shape. This wheel is the most efficient of all types and is the quietest at high static pressure. The backward-inclined fans are generally used in medium to large air handling systems. They are normally used for medium- and high-pressure systems, although they are, at times, used in low-pressure systems.

### **Axial Fan**

Axial fan flow is moved parallel to the shaft on which the fan wheel is mounted. Axial fans use either a direct drive or a belt drive. The three main types of axial fans are propeller fans, tubeaxial fans, and

vaneaxial fans. Axial fans do not develop their static pressure by centrifugal force. The static pressure is gained from the change in velocity of the air when it passes through the fan wheel.

1. **A propeller fan** consists of a multi-blade impeller within an inlet ring or plate. Propeller fans are low-pressure, high-capacity units built either with the blades mounted on the shaft of an electric motor or a shaft for V-belt drive.
2. **A tubeaxial fan** consists of an axial flow wheel within a cylinder or tube. Tubeaxial fans may be used on low- and medium-pressure systems.
3. **Vaneaxial fans** are tubeaxial fans with guide vanes that straighten out the axial spiral airflow. Vaneaxial fans can be used in low-, medium-, and high-pressure systems.

## DAMPERS

Dampers are devices used to control or restrict the airflow. They commonly consist of a series of moveable blades mounted in a frame. One of the most obvious attachments to a damper is a damper motor or actuator. These control the opening and closing of the dampers, in response to signals from the control system. They fall primarily into three types: volume, backdraft, and fire dampers.

1. **Volume Dampers** - Volume dampers are devices used to vary the volume of air that passes through an air outlet, inlet, duct, fan, air handling unit, cooling tower, or condenser unit. They may vary the volume from 0 to 100 percent of capacity. Some volume dampers can be opened and closed by hand, while others are opened and closed by a pneumatic or an electric operator. The largest use of manual controlled volume dampers in cooling systems is for air balancing.
2. **Backdraft Dampers** - Backdraft dampers are devices used to limit the airflow within a duct to one direction and to stop airflow through a duct or opening when the fan is shut off. Backdraft dampers are opened automatically by the force of the airflow on the damper blades. They are closed automatically by a spring or weight counterbalance and by gravity. The counterbalances can be adjusted to allow the damper to pass the needed airflow. Backdraft dampers, because they are free to open and close easily, may rattle and make noise. To eliminate this, felt or vinyl strips can be placed on the damper edges, which will also help minimize the air leakage.
3. **Fire Dampers** - Fire dampers are devices used to close off individual sections of a building during a fire. Fire dampers are normally installed where a duct passes through a wall, partition, floor, or ceiling which is specifically designed to provide fire resistance. If ducts pass through barriers having a fire rating of up to and not more than one hour of fire resistance and can be assumed to present no further fire hazard, there is no need for fire dampers. If the wall, partition, ceiling, or floor is required to have a fire resistance rating for more than one hour, a fire damper is then required to properly protect the opening where the ductwork penetrates the wall. Fire damper blades are held open by a fusible link (replaceable) during normal operation of the building. If a fire occurs, the fusible link melts and the damper blades close automatically. For a cooling system to operate properly, all fire dampers must be

open all the way. Broken or damaged fusible links should always be changed, and fire dampers should never be wired open. Break-away type connections should be used to connect the ductwork to the fire dampers; solid connections should never be used.

4. **Smoke Dampers** - Smoke dampers are used for either smoke containment or for smoke control. The damper is basically the same as a volume damper, except the damper is classified and listed in accordance with Underwriters Laboratories, Inc. (UL) 555S, UL Standard for Safety Smoke Dampers Fourth Edition (1999). The damper is a two-position damper, i.e., the damper is either open or closed depending upon the control requirements. The dampers are opened and closed by a pneumatic or electric operator. The damper usually has low leakage characteristics.

## **LOUVERS**

These are the elements which allow air to be drawn in from outside or discharged to outside, without allowing rain into the building. Louvers are shaped such that rain falling or being blown onto the louver is captured and channeled back to outside. Louvers may be incorporated into the side of a building, or they can take the form of free-standing penthouse arrangements.

Each louver should be complete with a bird mesh to avoid small birds or large insects from being drawn into the ventilation system. Variations include sand filters for desert areas and double bank louvers for particularly exposed areas.

Problems encountered with louvers include louvers obstructed with leaves etc., supply and extract louvers which are located too close together allowing short-circuiting of stale air, or intake louvers located adjacent to areas in which vehicles run, allowing exhaust gases to be drawn into the building.

## **UNIT HEATERS**

A unit heater is an assembly of a fan and motor, a heating element, and an enclosure whose function is to heat a space. Generally, unit heaters use five different types of heating media: steam, hot water, gas indirect-fired, oil indirect-fired, and electric. Propeller fan units are the most popular units used; however, sometimes centrifugal fan units are used. Unit heaters are used for spot or intermittent heating, such as large outside doors. Unit heaters are used to heat garages, factories, warehouses, stores, etc.

## **DUCTWORK**

Ductwork is the system of ducts and ductwork accessories that are used to connect air handling units and fans with the rooms, spaces, or exhaust hoods with which they are associated. The material used for a duct system must be based on the availability of the material, expertise of the duct installer, the type of duct already installed, the location of the installed duct, and the environment it is planned to be used in. For example, a fume hood that handles corrosive fumes should be connected with a non-metallic polyvinyl chloride (PVC) or stainless steel duct. Metallic ducts are usually built from sheets of aluminum or galvanized steel. The ducts may either be built with round or rectangular cross sections. Non-metallic ducts are usually

built from fiberglass duct board, except for ducts handling corrosive fumes that are constructed from a PVC material. Fiberglass duct board sheets are generally used in locations where the duct will not be damaged by objects or personnel. All joints should be sealed with a special pressure-sensitive tape made for this purpose; standard duct tape should not be used. Round PVC duct systems are built from standard PVC duct and standard fittings. Fittings and ducts are connected with glue. Rectangular PVC ducts are of a special construction and should be made by people who are skilled in this work. Flexible ducts can be bought and used directly without further fabrication. They are available either insulated or non-insulated.

## **AIR FILTERS**

Filters are installed within the incoming airstream of ventilation or air conditioning systems to remove particles of dust, smells and pollution from entering or being circulated throughout the building. The process used to remove these contaminants from the air mechanically, electrically, or by absorbing them, is called air filtration. There are many different types and different grades of filter, used to remove different particles or pollutants. Typically, flat panel or peaked fabric filters are used for simple systems, and these are capable of removing most dust particles and general dirt. The common type of filters used in HVAC applications are -

1. **Impingement Filters** - Viscous impingement filters are of the panel or roll type with a viscous (tacky) coating on the media to hold the particles to the media. The coating is called an adhesive. Viscous impingement filters are made to trap large dust particles from the airstream. Most air-conditioning systems have this type of filter. There are four types of these filters: throwaway, cleanable, automatic renewable media, and automatic self-cleaning media.
2. **Dry Media Filters** - Dry media filters, as their name suggests, do not have the tacky coating that is on viscous impingement filters. The dry media filters take out particles from the air by interception and straining. Interception means to filter out particles using the natural forces of attraction between molecules. Straining means to take out particles that are too large to pass through the openings between the fibers.
3. **HEPA Filters** - HEPA stands for High Efficiency Particulate Air. The HEPA filters work on diffusion principle to remove particulate matter and are extremely important for maintaining contamination control in clean room environments. These filter particles as small as 0.3  $\mu\text{m}$  (microns) with a 99.97% minimum particle-collective efficiency. This is remarkable considering that the outside air we breathe may contain up to 5 million suspended particles of dust, smog, and pollen in one cubic foot.
4. **Activated Carbon Filters** - A filter made of activated carbon will get rid of solid particles, as well as odor-causing gases and bacteria from the airstream. It is possible to clean and reuse the carbon filters. However, this is best done by the manufacturers, who will take out the carbon and process it to be used again.

5. **Electrostatic Filters** - The inability of standard dry or viscous type filters to take out fine dust particles from airstreams has led to the development of the electrical precipitator. The precipitation method consists of giving an electrical charge to each dust particle in the airstream by passing the air between electrodes and then collecting the dust on parallel plates as the air flows between the plates.

## CONDENSER & CONDENSING UNITS

Condensers can be put in the following groups: water-cooled, air-cooled, and evaporative. The term "evaporative," when used in reference to the condensing process, refers to the cooling effect brought on by the natural evaporation of water exposed to air currents. The heat rejected by a condenser comes from the heat absorbed by the evaporator and the heat of compression that is added by the compressor. Since the compressor and condenser work as one to compress and condense refrigerant vapor, these two parts, when combined into one package, is called a condensing unit.

1. **Shell & Tube Condensers** - Shell-and-tube condensers are used for most of the water-cooled refrigeration systems. The shell-and-tube type of water-cooled condenser is like the direct expansion water chiller. But most shell type water-cooled condensers have the cooling water flowing inside the tubes, and the refrigerant that it condenses is inside the shell, but outside the tubes.
2. **Air Cooled Condensers** - Air-cooled condensers are most popular in areas where water is in short supply, where there is a costly water supply, or where the use of water for air conditioning is restricted at times. They also find wide use in those jobs where low maintenance is a prime need. In addition, air-cooled condensers are used in a lot of installations, because they keep down the cost and do away with the installation of water pipe. They also do not require drainage to keep them from freezing in areas where the climate changes a lot and the cooling system must be turned on and off several times in a year. Propeller fan air-cooled condensers use a fin-and-tube coil like the coil described in the Direct-Expansion Coils section. The refrigerant vapor is condensed inside its tubes by giving up heat to air which flows across the coils. These condensers are, in most cases, placed outdoors, or at least the air is taken to the outdoors.

## DIFFUSERS, REGISTERS & GRILLES

Supply, return and extract grilles are used as the final point of entry or exit from the ventilated or air conditioned space. They can be wall mounted, ceiling mounted or floor mounted, according to the air distribution required within the space.

Supply grilles must introduce the air into the space in the most effective way, without causing unpleasant draughts.

The location, type and size of the grille is important. Supply and extract grilles must also be sized such that they do not cause significant pressure loss for the air passing through them, which would adversely affect the fan power, or create noise due to higher air velocities through the grille.

Usually, the diffuser is a supply air outlet having a square or circular shape. A grille is usually used for returns or an extract terminal unit and is rectangular shape. The term “register” means a grille or diffuser with integral volume control damper.

## **PUMPS**

The type of pump used to distribute chilled or hot water through the coils in air handling units varies with the system design. For systems less than 10 hp, monoblock pumps are selected and for sizes over 10 hp, horizontal split casing pumps are selected. The pumps can be arranged in primary-secondary arrangement for energy efficiency and for large installations variable frequency drive (VFD) pumps should be selected.

## **VALVES & PIPING**

Valves installed in the air handling system are to control water flow and to isolate equipment for ease of operation and maintenance. There are several different physical types of valves.

1. A **check valve** is used to prevent fluid from going backwards; it allows flow in only one direction. If two parallel pumps are installed in a system but only one of them is running, a check valve at the pump discharge can prevent water from going back through the second pump.
2. A **gate valve** is used to isolate equipment and piping loops. A gate valve on both the suction and discharge sides of each pump would allow the pump to be removed for maintenance while the system continues to operate on the parallel pump.
3. A **globe valve** is used to throttle the liquid flow rate and provide precise control for modulating service. Most kitchen faucets are this type. Because the pressure loss through an open globe valve is much higher than through a gate valve, globes should not be used for isolation applications. Conversely, gate valves are a poor choice for flow control situations, since they allow most of the flow to occur when they are only about 10% open.
4. A **triple-duty valve** is often specified for the pump discharge. This single valve serves the function of a check valve, isolation valve, and flow control valve. One trait that all three of these valves share is a linear action to operate (the valve opens as the valve stem rises).
5. **Butterfly valves** are most often used on larger pipes, typically 2½ to 12 inch and larger. They are often the only choice for controlling large-piping systems such as chillers, boilers, cooling towers, and thermal storage systems. These valves require the least opening torque and they control flow by rotating a disc within the valve body 90 deg from open to close. A key consideration when using butterfly valves for proportional control is their vulnerability to an extreme pressure drop in some applications. Unbalanced forces on the disc during high drops can cause oscillations, poor control, and/or damage to the linkage and actuator, even when the critical flow point is not reached. As a result, butterfly valves must be sized and selected using conservative pressure drop criteria.

6. **Ball valves** can be used for isolation, flow control or both and these provide tight close-off. In small sizes, ball valves are usually the cheapest option. These are available in two- and three-way configurations; two-way ball valves have equal percentage flow control characteristics, and the flow can be in either direction. Three-way models have linear flow control characteristics and can be used in diverting or mixing service, with some restrictions. When good but not precise control is necessary, motorized ball valves can be used instead of globe valves in many applications. These include heat exchangers; air handling unit heating/cooling water coils and steam heating coils; preheat coils; humidifiers; and unitary equipment such as reheat coils, unit heaters, convectors, radiant panels, fan-coil units, and unit ventilators. Lower cost is a major advantage of a ball valve; it might cost only half as much as a comparably sized linear globe valve or other valve type.

### **Globe valve or Ball valve**

Globe and ball valves are the most frequently used valves for modulating service. While motorized ball valves can be used in most common non-central plant HVAC control applications, they cannot always replace globe valves. Globe valves have strengths that make them popular for use with HVAC controls. Here are other factors to consider:

1. Globe valves should be used when precision control is a higher priority over broad range of conditions.
2. Globe valves are available in many pipe sizes, typically from ½ to 6 inches.
3. In a modulating control loop, 1/2 in. ball valves with very small reduced ports are most suitable for two-position control due to the lack of a "throttling" ability of the small port.
4. If noise is a primary concern, a globe valve may be a better choice.
5. Globe valves can handle a wide range of Cv capacities (from <1 to 400), flow characteristics, temperature, and pressure requirements. For low-flow modulating control at Cv <1, globe or zone valves are suggested.

### **CONTROL VALVES**

Control valves are used to maintain space temperature conditions by altering the flow of steam, water, gas, and other fluids within an air-conditioning system. Valves must be properly sized and selected for the particular application. Valves can be two-position or modulating 3-port configuration.

Two-way valves throttle flow while three-way valves divert or mix flow. Two-way valves have two ports and are used to control the flow in variable flow systems. Three way valves are commonly used in hydronic heating systems, although the name is really a misnomer. While these valves do have three ports, the fluid enters one port and exits either the second or third port, depending on the valve setting. Three-way valves are also available with two entry ports and a common discharge port. The type of three-way valve selected will determine its location in the system.

**Mixing Valves-** A three-port valve with *two inlet flows and one common outlet flow* is defined as a mixing valve, and so provides a variable temperature outlet at a constant flow rate. A three-port motorized valve can be used to MIX, in varying proportions, two flows of different temperatures while maintaining a constant rate of flow in the common outlet port. A Mixing Valve is used normally for radiator circuits.

**Diverting Valves-** A three-port valve may also be used to DIVERT a common flow in varying proportions. The valve will have one inlet and two outlets and provides a constant temperature and variable flow rate. A diverting valve is used normally for circuits with convective heat transfer such as; heat exchangers, primary coil in indirect cylinder, heater battery, cooling coil. Diverting valves in bypass applications are placed upstream of the coil. Diverting applications are commonly used in constant flow systems where full flow across the coil is not required because of partial load system conditions.

### **2-way Valve or 3-way Valve**

A 2-way valve is best when applied with variable speed pumps. Rather variable-pumping systems should only use 2-way valves to reap the energy saving benefits.

Constant volume systems may employ 2-way or 3-way valves. While pumping costs will decrease to small amounts with 2-way valves, other problems occur. The 2-way valves in a constant volume system may sometimes lead to balancing problems in a large network and may lead to water scarcity at some terminal locations. The pumps must incorporate the minimum recalculating system should the 2-way valve/s close to 100% close position. Systems incorporating 3-way valves ensure continuous circulation.

All of these valves can be operated manually, or fitted with an actuator and controlled automatically. When on/off control is required, a solenoid valve is specified. When the flow must be allowed to vary from closed to full capacity, a modulating valve is selected. Many types of systems require the installation of a bypass valve around a piece of equipment to control the flow rate through the equipment.

## **HEAT RECOVERY DEVICES**

Heat recovery devices are used to transfer heat between the intake fresh air and the exhaust air. This is useful in situations where a large amount of air has to be expelled, particularly when it is cold. In an office building situation, the fresh air quantities are normally quite small and this can make heat recovery fairly unattractive. It is very important to make sure that you have addressed all the possible savings from improved fresh air and recirculation control before considering heat recovery.

Options for heat recovery include:

1. **Run around coil** - In this arrangement, water is circulated between coils in the two ducts. A run-around coil system is a simple piping loop with an upstream precooling coil and a downstream reheating coil that sandwiches the main cooling coil. The circulating fluid is pumped to transfer heat from the warm mixed air to the off coil cold supply air. The run-around system reduces the cooling load

on the main cooling coil; reheat is provided by the heat picked up by the circulating fluid in the precooling coil instead of by an external source of expensive energy.

2. **Plate heat exchanger** - In this arrangement, a heat exchanger is situated to allow direct transfer of heat from one flow to the other. Heat is transferred from outdoor air coming into the air conditioner to the cold air leaving it. Again, the goal is to boost the portion of air conditioning capacity used for removal of latent heat by decreasing the need to remove sensible heat. To a limited extent, the exchanger itself will remove latent heat by condensing moisture on the entering air side. Outdoor air is introduced into one side of the heat exchanger, and is partially cooled. It then flows over the cold refrigeration coil for moisture removal and additional sensible cooling. The cold, saturated air then passes through the other side of the exchanger for warming before being introduced to the air handler or the space.
3. **Heat Pipe System** - In its simplest form, a heat pipe is a metal tube sealed at both ends, evacuated and charged with a vaporizable liquid (refrigerant). The liquid refrigerant at the bottom end readily turns to gas when that end of the pipe is warmed, and floats to the top end of the pipe. If that end is in a cooler environment, the gas condenses, releasing heat. The liquid then flows back to the bottom where the cycle begins again. The net result is heat transfer from bottom to top, without a compressor. Capillary action is sometimes used to help move the liquid, allowing for greater flexibility in configuration.
4. **Thermal Wheel** - In this arrangement, a rotating wheel is used to transfer heat from one air stream to the other. And energy recovery wheel can be incorporated into a ventilation system to transfer both the sensible and latent energy between outdoor and exhaust air streams. The core of an enthalpy wheel can be made from a variety of materials such as paper, metal or plastic, which is coated with a desiccant. This coating enables the wheel to transfer both sensible and latent energy between air streams. The enthalpy wheel provides first stage cooling or heating. For instance, in the summer the wheel removes moisture from incoming air and pre-cools it to lighten the load on the evaporator coil. Likewise, in colder temperatures (winter application) the wheel will inject moisture into supply air and pre-warm it to reduce the load on the reheat coil. In the summer and winter modes, the wheel saves energy. There are three general types of wheels being used today. They are sensible, enthalpy and regenerative.
  - **Sensible wheel** - This wheel is not coated with a desiccant and therefore transfers only sensible energy. The wheel can be constructed of almost any material (paper, metal or plastic) and transfers energy between two air streams as the mass of the material gains or loses heat to the opposite air stream. The wheel rotates at a speed of 25 to 50 revolutions per minute.
  - **Enthalpy wheel** - It is similar to the sensible wheel except that a desiccant media is added to the wheel's surface. As the wheel rotates, it now can transfer sensible energy and humidity. This wheel also rotates at 25 to 50 revolutions per minute.

- **Regeneration wheel-** This wheel is used when low dewpoint conditions (<45°F) are required, such as industrial applications. It achieves low dewpoints by slowing the wheel to a speed of between 0.25 and 1 revolution per minute and by using an air stream heated to 250°F or more to drive off moisture and regenerate the wheel.

This heated air stream is typically focused on only 1/4 of the wheel's area thereby allowing 3/4 of the area to be available for the process side.

## **HVAC CONTROL SYSTEMS**

Controls for heating ventilating and air conditioning (HVAC) cover a broad range of products, functions, and sources of supply. The application of HVAC controls starts with an understanding of the building and HVAC systems, and the use of the spaces to be conditioned and controlled. The type of HVAC system determines the control sequence. Several types of control products such as pneumatic, electric, analog electronic, or electronic direct digital control (DDC) can then do the basic control sequence.

### **HVAC Controls**

HVAC systems are classified as either self-contained unit packages or as central systems. Unit package describes a single unit that converts a primary energy source (electricity or gas) and provides final heating and cooling to the space to be conditioned. Examples of self-contained unit packages are rooftop HVAC systems, air conditioning units for rooms, and air-to-air heat pumps.

Central systems are a combination of central supply subsystem and multiple end use subsystems. End-use subsystems can be fan systems or terminal units. If the end use subsystems are fan systems, they can be single or multiple zone type. With central systems, the primary conversion from fuel such as gas or electricity takes place in a central location, with some form of thermal energy distributed throughout the building or facility. The typical uses of central systems are in larger, multistoried buildings where access to outside air is more restricted. Typically central systems have lower operating costs.

### **Basic Control**

Basic control regulates the amount of heating or cooling necessary to meet the load in conditioned spaces. Minimum outside air needed for ventilation is provided whenever a space is occupied. When outside air temperature is a suitable source for free cooling, it's controlled as needed at values greater than the minimum. The approach in packaged unitary equipment is to control the generation of heating or cooling by space thermostats. The approach in central systems is to control the delivery of heating and cooling by the end use zones to match the load in the space. The supply is controlled to match the load imposed by all the zones. A typical method of doing this is for room thermostats to control zones, and discharge controllers to control central supplies. Discharge temperature controllers control the rate of primary conversion (chillers or boilers), and pressure controls determine the delivery rate of the pumps or fans distributing the central supply. In many cases there are multiple boilers and/or chillers and pumps, which are put on or off line as

necessary to provide proper capacity. Those online are modulated as necessary to meet load needs. The controls to put units online and off-line would normally be applied to meet the system needs.

Devices that sense the condition of air in a space or in an airflow system act upon other devices to make the air behave in the manner desired.

1. **Thermostat** - A thermostat or other temperature control device may move a damper that directs the path of an airstream. It may also change the temperature of an airstream by directing its flow through a coil, or it can control the volume of air flowing in a duct system. Through the action of a valve, it also may change the temperature of an airstream. Humidistat for humidity control provides a signal to the 2-way or 3-way control valve to regulate the chilled water supply to the cooling coil. The humidistat signals normally take precedence over the temperature signals.

2. **Pressure Controls** - Pressure controls operate to control the pressure of air in a room, or the duct system through the action of dampers. The damper being controlled is in the inlet duct to the supply fan, but it could equally well be an inlet vane damper or an outlet damper.

The pressure controller could also operate a blower drive speed control. In this control, the pitch of motor and fan pulleys is varied by a device in response to a signal from the pneumatic static pressure controller.

3. **Fan Controller** - Control of fan speed to control pressure and airflow volume results in less noise than when inlet vanes or outlet dampers are used. In certain installations, the use of speed control also cuts down the horsepower that is needed by the fan or blower drive motor.

4. **Airflow Switches** - Airflow switches are mounted on the side of a duct with the blade inserted into the duct. The blade of the switch will move according to airflow in the duct, and it will make electrical contacts when air flows and break the contacts when airflow stops. The sensitivity of the switch to the airflow may be adjusted. Another control for the same purpose as the ones described above is the differential pressure switch that senses velocity pressure in the duct. This controller also has an adjustable pressure range.

### **Supervisory control**

The role of supervisory control is to control the scheduling and interaction of all the subsystems to meet building needs. Supervisory control systems have many names; each used for a particular emphasis.

Among the names their acronyms are the following:

1. BMS: Building management system
2. EMCS: Energy monitoring and control system
3. FMS: Facility management system
4. EMS: Energy management system

5. BAS: Building automation system (The most generic of these terms)

### **Building Automation Systems**

The development and use of computers and microprocessors has caused great changes in the HVAC controls industry. Minicomputers were installed on jobs to collect data to provide centralized control. Then, microprocessors were used for remote data-gathering panels to gather data and provide direct digital control. DDC (direct digital control), is sometimes used to describe everything a computer or microprocessor-based control system does.

Modern BMS have a high level of DDC programmed in at all levels, so that you have a central "brain" in charge, but each part of the system can operate independently for some time without connection to the central brain. Such systems can also be used to monitor and control other items such as building security and access. There can be a risk that adding too many systems onto a BMS causes the system to slow down and become less effective.

From the perspective of the building or energy manager, consider what is important to managing the building. This gives a top down approach to selecting the correct data that can be combined to present information. Examples may be:

1. Room temperatures
2. Outside air temperature
3. Chiller common faults
4. Cooling tower common faults
5. Boiler system common faults
6. Electricity consumption for each tenancy
7. Gas consumption
8. Fire alarm activation
9. Security alarm
10. Plant operation (on/off)

This may then be presented to an operator in several different forms such as trend graphs for later analysis, graphic system diagram with flashing alarm areas, alarm printouts or callout paging etc. A building management system that just gives you screens of numbers is more useful as a paperweight than as an information system.

## **Control components**

For awareness purposes, we will briefly describe the major components of a modern control system below.

### **The central controller**

Modern building management systems consist of a central computer, which normally has a screen that an experienced operator can use to interpret and alter performance. This is linked to controllers by a network, which operates as a two-way channel for information and commands throughout the system. Local controllers and sensors are connected to this data-bus and do the work of controlling individual systems.

In some systems, there may not be any screen, but just a box with a small LCD readout. Such systems normally have the capability of providing a full screen readout. However, without such a screen they are very difficult for the inexperienced operator to work with and represent a barrier between the building manager, the energy manager, or any external consultant and the control system.

### **I/O Points**

The information presented upon a BMS is derived from monitoring the status of inputs and outputs. Input points provide information to the controls system, e.g. temperatures, pressures etc. Output points are the control signals to equipment. Each input or output (termed an I/O point) provides an electronic interface between the BMS computer equipment and the wires in the building. Inputs and outputs can be either:

1. Digital, i.e. on or off, such as the signal to turn a system on and off at the beginning and end of a day; or
2. Analogue, i.e. continuously variable over a range, such as a temperature signal.

Special modules are required to provide the I/O points and each system has a limitation on the total number of points that can be connected. Naturally the more points a system is capable of monitoring or controlling, the higher the system costs. Analogue points are also usually more expensive than digital points.

The I/O is arranged in blocks to suit a computer addressing method so they are usually purchased as standard modules containing 4, 8, 16 or 32 points. Separate modules are usually required for the dedicated type of I/O i.e. input, output, analogue, digital, range or voltage level etc. When new points are required a complete module may have to be installed.

1. **The Central Controller** - The central controller is the computer that provides the central brain of the system. It will normally have some sort of read-out and can generally be made user-friendly. However, often these units are left as 'black boxes' which can make them difficult for anyone other than the controls company to work with.
2. **I/O Points** - These are the input and output points that the control system uses. Input points provide information to the controls system, e.g. temperatures, pressures, etc. Output points are the control signals to equipment. I/O points can be digital (i.e. on/off) or analogue (i.e. continuously varying).

3. **Network** - The network is a communications system that connects the central controller to the local controllers. Some systems use 'open' communication protocols, which allow controllers of many manufacturers to talk to each other. These systems are generally preferable to systems that are manufacturer-specific.
4. **Dedicated Controllers** - These are controllers that operate specific devices and are generally located near the system they are controlling.
5. **Programming** - Like any computer system, controls systems need a set of instructions to make them work. The quality of programming of a controls system will determine how well it works.
6. **Maintenance** - Controls systems require some maintenance of hardware, particularly with respect to sensors. Programming also has to be kept up-to-date to keep pace with changes in the building

### **Efficiency opportunities**

From the energy management perspective, the most important function is to optimize control. The concept of optimizing control is not only to control space conditions, but also to do it in a manner that minimizes the energy and costs when different forms of energy are available. An optimizing strategy is generally to improve the efficiency of primary supply equipment or to reduce the losses of energy in end-use systems.

Here are some of the critical control strategies that can save energy.

1. **Select realistic operating hours** - For any building that shuts down overnight, every extra hour per day of operation represents approximately 7% additional air-conditioning energy. Don't run the building for a handful of early birds or night owls - generally conditions in the building will be near enough to normal comfort levels without extended hours.
2. **Select realistic space conditions** - Controls should be set up to provide a dead band between 68°F and 73°F where neither heating nor cooling will occur. This band reduces starting demands on the plant and saves energy by recognizing that people dress differently during heating and cooling seasons.
3. **Logical zoning of HVAC areas** - Zoning so that HVAC areas of similar load characteristics are controlled together can reduce energy use considerably by avoiding the amount of re-heat needed to maintain conditions. In general, this is only possible at the time of construction or major refurbishment. However, changing building use may mean that sensors can be relocated to better reflect building conditions. In some cases, relocation of partitions can isolate sensors from the systems they control, under which circumstances it is essential to relocate the sensor back into the relevant conditioned space.
4. **Early morning warm-up or cool-down** - The strategy is to seal the building from the introduction of outside air and apply maximum heating / cooling to achieve design conditions in the minimum time. It is

necessary to establish that the building will not be occupied during this period and that the building has enough thermal storage to warrant using the system.

5. **Night time cool flush** - This strategy uses "low heat" night air to cool the structure of the building when the internal temperature is above the lowest comfort temperature. An additional advantage is that internal air quality will be improved. When evaluating the economics of this system, assess the power requirements of the fans required. It may be no cheaper than using the chiller plant for a short period before occupancy; however this technique does not improve air quality.
6. **Fresh air control** - When it is cooler outside than inside, it is often possible to use outside air to provide cooling.
7. **Scheduling** - Sophisticated control systems with 365 day clocks can be scheduled to ensure that plant does not run on all days offices are not in use. Starting and stopping times can also be changed when daylight saving commences and ceases. Continued management is required to update the program for changes such as moveable holidays and so on.
8. **Optimum start/stop routines** - These routines monitor the time taken for the building to reach design conditions in the morning and to depart from design conditions when the HVAC is shut off at night. The start and stop times are progressively modified over a number of days until a good match with the building requirements is achieved. The optimization routine continues to modify the start and stop times as the seasons change.
9. **Improving Part Load Performance** - The sizing of equipment is to meet maximum loads, but the equipment is usually run at less than maximum load. This means that the part -load characteristics of the equipment determines the efficiency in meeting a given load. When there are multiple chillers or boilers, an optimizing strategy would be to choose the most efficient equipment that has the capacity to meet the part load at any given time.

While modern day controls have immense potential to capture data, it is useless unless it can be associated with other data to provide some useful information. Don't try to load your control system too much.

Remember, when it comes to control, it may be better to have a building that is dumb and reliable than a building that is smart but scatterbrained. A simple strategy to minimize risk in this respect is to keep the controls simple and robust rather than complex.