



PDHengineer.com

Course Nº M-1029

Process Piping Part 6 - Ancillary Equipment



This document is the course text. You may review this material at your leisure before or after you purchase the course. If you have not already purchased the course, you may do so now by returning to the course overview page located at:

<http://www.pdengineer.com/pages/M-1029.htm>

(Please be sure to capitalize and use dash as shown above.)

Once the course has been purchased, you can easily return to the course overview, course document and quiz from PDHengineer's My Account menu.



If you have any questions or concerns, remember you can contact us by using the Live Support Chat link located on any of our web pages, by email at administrator@PDHengineer.com or by telephone toll-free at 1-877-PDHengineer.

Thank you for choosing PDHengineer.com.

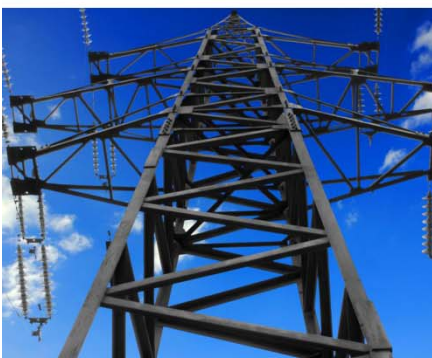

17350 State Highway 249 | Suite 140 | Houston, TX 77064

Chapter 11 Ancillary Equipment

11-1. Flexible Couplings

Flexible couplings are used to join pipe sections, to insulate sections from one other, to absorb concentrated pipe movement, and to join plain end pipe to flanged valves and other equipment. The basic purpose of flexible couplings is to provide flexible but leak-tight connections that will last for the life of the piping. Flexible couplings are generally available in sizes from 15 mm (½ in) to 1.8 m (6 feet) and larger.

a. Metallic Flexible Couplings

The basic configuration of a flexible coupling is a metallic middle ring that slips over the joint between two pipe sections with a gasket and a follower at each end. This configuration compresses the gasket and seals the middle ring (see Figure 11-1). The middle ring can be provided standard in a number of different materials, such as plastic or rubber lined, stainless steel, aluminum, Monel, carbon steel, and ductile iron (see Appendix B for the proper material and contact the manufacturers to determine availability). The gaskets are likewise available in different materials (typically, elastomers and rubber materials).

b. Transition Couplings

Similar to flexible couplings in construction, transition couplings connect pipe with a small difference in outside diameter: the middle ring in transition couplings is pre-deflected to adjust for the differences in diameter. As with the flexible couplings, the transitional coupling's middle ring and gaskets are available in different materials, depending upon the application.

c. Flanged Couplings

Flanged couplings are typically provided with a compression end connection on one end and a flange on the other. The flanges can be provided in different ANSI or AWWA standards, as required for the application. The manufacturer should be consulted for pressure ratings.

d. Couplings for Non-metallic Piping

Flexible couplings for non-metallic piping are very similar to metallic piping couplings. There are three main configuration alternatives for these couplings. The first is the same configuration as the metallic piping, in which there is a middle ring that is sealed by gaskets and held in place with end pieces that are bolted together. The second method is very similar, except that the end pieces are lock rings, similar to compression fittings, threaded to hold the middle ring in place. In both instances, the wetted-parts materials are selected in order to meet the application. The last type of typical flexible coupling for non-metallic piping is a bellows expansion joint (see Paragraph 11-8c). The bellows expansion joints can accommodate directional changes of compression/extension and lateral offset and angular rotation of the connected piping; however, these joints are not capable of absorbing torsional movement. If a bellows expansion joint is used as a flexible connector, a minimum of two corrugations should be provided. The potential movement of the bellows is calculated to obtain the proper number of corrugations.

11-2. Air and Vacuum Relief

During startup, shutdown and in normal operations, it is common for liquid process piping system to produce situations where air needs to be exhausted or allowed to re-enter. The devices used include air-release valves, air-vacuum valves, vacuum breakers, and combination air-release and air-vacuum valves. The type of valve required varies for the specific applications.

a. Air-release Valves

For liquid process piping in which air tends to collect within the lines (as occurs under pressure systems as air dissolves and then reappears as the pressure decreases), air-release valves are necessary. A very common operating problem occurs when air collects in the high places of the piping systems, producing air pockets. These air pockets can reduce the effective area of the pipe through which the liquid can flow, causing a problem known as air binding. Air binding results in pressure loss, thus increasing pumping costs.

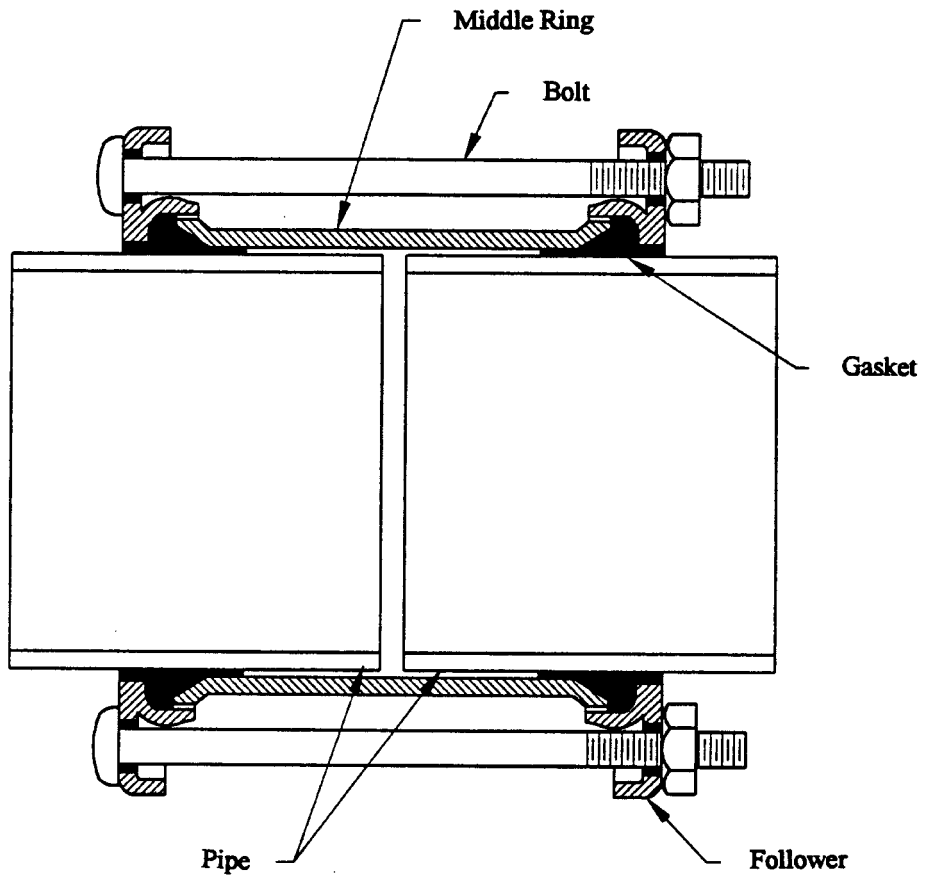

Figure 11-1. Flexible Coupling
(Source: Dresser Industries, Inc., "Style 38 Dresser Couplings for Steel
Pipe Sizes, Sizes and Specifications," Form 877-C Rev. 1095)

It is typical for air-release valves to be installed to eliminate these problems. Air-release valves should be installed at pumping stations where air can enter the system, as well as at all high points in the pipeline system where air can collect. Air-release valves automatically vent any air that accumulates in the piping system while the system is in operation and under pressure. However, the potential for accumulating hazardous gases must be taken into account, and the vents located in a manner such that it does not cause a hazardous atmosphere for the operators. Air-release valves do not provide vacuum protection nor vent large quantities of air as required on pipeline filling; air-vacuum valves are designed for these purposes.

The sizing of air-release valves is based upon engineering judgement and experience. The parameters which affect valve size are the potential for air entrainment, pipe diameter, volumetric flow rate, system pressure, fluid viscosity, surface condition of the pipe wall, and the degree of pipe slope adjacent to the piping high point. Manufacturers' data can assist in the selection.

b. Air-Vacuum Valves

For piping systems that are used intermittently and are therefore periodically filled and drained, air-vacuum valves are used to prevent damage to the piping system. The damage could result from over-pressurization and velocity surges during filling, or collapse during draining.

Air-vacuum valves are installed at piping high points. These valves are float operated, have large discharge and inlet ports that are equal in size, and automatically allow large volumes of air to be rapidly exhausted from or admitted into a pipeline. As with air-release valves, the potential for releasing hazardous gases must be addressed in the design and the vents located to permit a hazard condition for personnel. Air-vacuum valves will not vent gases when the piping system is in normal operation and under pressure. Air-release valves are designed for that purpose.

The sizing of air-vacuum valves is performed independently for each location and requires the review of both functions; i.e., air exhaust and air intake. The largest valve required for either function is selected. The flow capacity required is compared to manufacturers' data relating acceptable pressure drop to valve size. The flow capacity requirements are determined as follows:

$$Q_{\text{exhaust}} = Q_{\text{max}}$$

where:

$$Q_{\text{exhaust}} = \text{volumetric flow rate of exhaust air, m}^3/\text{s (ft}^3/\text{s)}$$

$$Q_{\text{max}} = \text{maximum liquid filling rate, m}^3/\text{s (ft}^3/\text{s)}$$

$$Q_{\text{intake}} = Q_{\text{gravity}}$$

where:

$$Q_{\text{intake}} = \text{volumetric flow rate of intake air, m}^3/\text{s (ft}^3/\text{s)}$$

$$Q_{\text{gravity}} = \text{gravity flow rate of liquid during draining, m}^3/\text{s (ft}^3/\text{s)}$$

c. Vacuum Breakers

Two primary types of vacuum breakers are available -- atmospheric and pressure. Atmospheric vacuum breakers operate in the event of total pressure loss. Pressure vacuum breakers provide protection against back siphonage and pressure surges. The configuration of pressure vacuum breakers vary by manufacturer. The configuration used to prevent back siphonage of hazardous liquids often involves a check valve as well as an air intake.

Figure 11-2 depicts a combination pressure vacuum breaker and its typical installation requirements. The pressure vacuum breaker is a spring-loaded check valve that opens during forward flow and is closed by the spring when the flow stops. When the pressure drops to a low value, a second valve will open and allow air to enter the breaker.

The configuration used for applications that may involve pressure surges have associated air-release valves. The latter arrangement allows the large volumes of air, admitted by the vacuum breaker, to be slowly exhausted by the air-release valve under operating conditions and act as a pressure surge reservoir.

d. Combination Air-release and Air-Vacuum Valves

The operating functions of both an air-release valve and an air-vacuum valve are accommodated in a single combination air-release and air-vacuum valve. Using this type of valve in lieu of air-release and air-vacuum valves

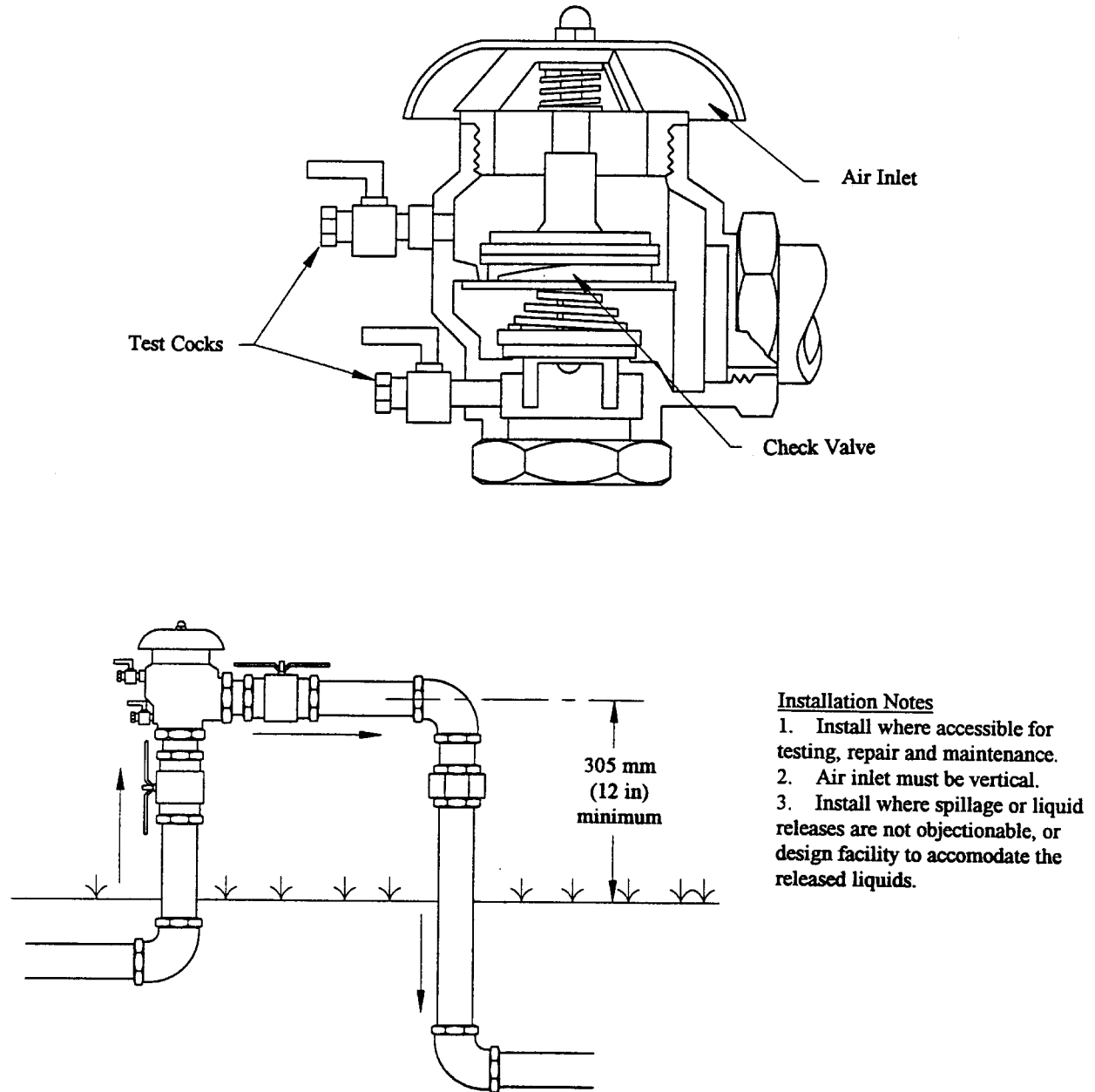

Figure 11-2. Pressure and Vacuum Breaker
(Source: FEBCO, Service Information Model 765 Pressure
Vacuum Breaker Assembly, vendor bulletin Oct 89)

typically provides the piping system with maximum protection. However, each individual location should be carefully reviewed.

e. Air and Vacuum Relief Application

Suggested application of air and vacuum relief devices into the piping design is as follows:

- Locate air-vacuum valves at all system high points where the piping system will be likely used intermittently. For non-hazardous service with continuous operations, manual valves or other methods may be more cost effective.
- Locate combination air-release and air-vacuum valves at all system high points where the potential for air accumulation exists.
- Locate air-release valves at intervals of 500 to 850 m (1,640 to 2,790 ft) on long horizontal pipe runs lacking a clearly defined high point. Air-release valves are installed with an isolation valve, typically a full port ball valve, between the air-release valve and the piping system for maintenance purposes.
- Locate vacuum breakers on closed vessels.

11-3. Drains

All low points in liquid process piping systems should be provided with drain or blow-off valves. These valves allow flushing of sediments from, or draining of, the entire lines. The most common valves used for draining purposes are gate valves. If rapid draining is not important, globe valves may also be used, provided that sediment accumulation is not a concern. Pipelines 50 mm (2 in) and smaller should use 15 mm (½ in) valves, as a minimum size. Pipelines that are 65 mm (2½ in) or greater should have a minimum valve size of 20 mm (¾ in).

11-4. Sample Ports

Materials of construction for sample ports and sample valves match the piping system and the required application. Coordination with CEGS 01450, Chemical Data Quality Control, is necessary to ensure proper sampling.

a. Port Locations

Sample piping should be as short as possible, protected from physical damage, and easily accessed by operators. Sample connections are made on feed, intermediate and product streams for process control. Process engineers are consulted in order to determine the number and location of sample ports.

b. Design Requirements

It is recommended that the minimum size connection to either the process equipment or the piping be 15 mm (¾ in). If the sample line is longer than a meter (approximately 3 feet), two valves are installed in the sample line. The first valve is located as close to the actual sample point as possible. The second valve is a final block valve and should be located near the end of the sample piping. The valves should be quick opening, either gate or ball type, and all materials of construction should meet the application.

11-5. Pressure Relief Devices

The ASME B31 Pressure Piping Code provides the standards and requirements for pressure relief devices and systems including piping downstream of pressure relief devices. Table 11-1 provides a summary of the relief pressure limits, but these limits shall not be used without consulting the proper ASME B31 section. Note that high pressure piping is not included.

a. Pressure Relief Valves

Pressure relief valves are automatic pressure relieving devices that protect piping systems and process equipment. The valves protect systems by releasing excess pressure. During normal operation, the valve disc is held against the valve seat by a spring. The spring is adjustable to the pressure at which the disc lifts. The valve disc lift is proportional to the system pressure so that, as the system pressure increases, the force exerted by the liquid on the disc forces the disc up and relieves the pressure. The valve will reseat when the pressure is reduced below the set spring pressure. Pressure relief valve materials and process pressure range must be accounted for to specify the correct pressure relief device.

Table 11-1 Summary of Pressure Device Limits		
Service	Relief Set Limit	Code Reference
Metallic Piping - Category D Service*	# 120% design pressure	ASME B31.3 - 322.6
Nonmetallic Piping - Category D Service	= design pressure	ASME B31.3 - A322.6
Metallic Piping - Category M Service**	# 110% design pressure	ASME B31.3 - M322.6
Nonmetallic Piping - Category M Service	= design pressure	ASME B31.3 - MA322.6
<p>Notes: *Category D Service is a fluid service in which the fluid handled is non-flammable, nontoxic and not damaging to human tissues; the design pressure does not exceed 1.035 MPa (psig); and the design temperature is from -29EC (-20EF) to 186EC (366EF). (ASME B31.3, p. 5.)</p> <p>**Category M Service is a fluid service in which the potential for personnel exposure is judged to be significant and in which a single exposure to a very small quantity of a toxic fluid, caused by leakage, can produce serious irreversible harm to persons on breathing or bodily contact, even when prompt restorative measures are taken. (ASME B31.3, p. 5.)</p> <p>Source: ASME B31.3, Reprinted by permission of ASME.</p>		

b. Rupture Discs

A rupture disc is another form of a pressure relief device. Rupture discs are designed to rupture automatically at a predetermined pressure and will not reclose. These discs can relieve very large volumes of liquid in a rapid manner. Materials of construction include metals, graphite or plastic materials held between special flanges and of such a thickness, diameter and shape, and material, that it will rupture at a pre-determined pressure. There are also metal rupture discs coated with plastics. In addition, for highly corrosive service, precious metals such as silver, gold, and platinum are also used.

Pressure relief valves and rupture discs may be used in series. In such cases, rupture discs are designed to rupture at a pressure approximately 5 to 10% above the pressure at which a relief valve is designed to activate. In this manner, the rupture disc acts as a backup device. It can be used upstream of a safety relief device to protect the valve components from corrosion or malfunction due to process materials. Rupture discs are occasionally placed downstream of relief valves in manifolded relief

discharge systems where it is necessary to protect the discharge side of the pressure relief valve from corrosion. Gate valves (but not safety valves) may also be placed in front of rupture discs, allowing for shutoff or maintenance of the discs. Discs usually require periodic replacement as operating experience and conditions dictate.

Rupture disc sizing is based on the premise that, if adequate flow is allowed from the disc, pressure will be relieved. Rupture discs are not intended to be explosion relief devices. The following sizing equation is derived from Bernoulli's equation and the conservation of momentum, and can be used for liquid service. The equation assumes that the disc vents immediately to atmosphere (no relief piping) and that nozzle friction losses are negligible. Use of this equation complies with ASME B31 requirements, but its use should be reviewed with respect to local pressure vessel codes¹.

$$A = n \frac{Q}{K} \sqrt{\frac{s.g.}{P_r}}$$

¹ Fike Metal Products, Rupture Discs & Explosion Protection, p. 9.

where:

- A = required rupture disc area, mm² (in²)
- n = conversion coefficient, 2.280 x 10⁴ for SI units and 0.0263 for IP units.
- Q = flow, m³/s (gpm)
- K = flow coefficient (K = 0.62 per ASME B31)
- s.g. = specific gravity
- P_r = relieving pressure, MPa (psi)

Example Problem 9:

Assume that a toxic liquid with a specific gravity of 1.04 is flowing at a rate of 0.050 m³/s (800 gpm) through stainless steel piping that has a maximum working pressure rating of 2.207 MPa (300 psi). A rupture disc will be used as the primary relief device.

Solution:

Step 1. In accordance with ASME B31.3, a primary pressure relief device should not exceed 10% over maximum allowable working pressure.

$$P_r = (2.17 \text{ MPa})(110\%) = 2.39 \text{ MPa} \text{ (330 psig)}$$

Step 2.

$$A = (2.280 \times 10^4) \left(\frac{0.05 \text{ m}^3/\text{s}}{0.62} \right) \sqrt{\frac{1.04}{2.39 \text{ MPa}}} \\ = 1,213 \text{ mm}^2 \text{ (1.88 in}^2\text{)}$$

$$A = \frac{BD_i^2}{4} \gamma D_i \left(\frac{4A}{B} \right)^{0.5}$$

$$D_i = 39.3 \text{ mm (1.55 in), minimum}$$

Therefore, from Table 1-1 (page 1-2), the bore diameter of the pressure relief disc is 40 mm (1 1/2 in).

c. Safety Considerations

The use of pressure relief devices requires careful material selection and determination of activation pressure. In addition, the design includes means to collect the released liquid once it leaves the pipeline to protect the operators and the environment.

11-6. Backflow Prevention

Backflow prevention is often handled by three main methods, one of which is check valves which were discussed in Chapter 10. Another method is the use of pressure and vacuum breakers, which were discussed in Paragraph 11-2. The third method is use of a reduced pressure backflow prevention assembly.

a. Reduced Pressure Backflow Prevention

Reduced pressure backflow prevention assemblies are mandatory for the mechanical protection of potable water against the hazards of cross-connection contamination. Whenever the potential exists for hazardous materials to come in contact with potable waters, reduced pressure backflow prevention assemblies are required per AWWA standards.

The reduced pressure backflow prevention assembly typically has two Y-type check valves in series, in between which is located an internal relief valve. In a flow condition, the check valves are open with a liquid pressure that is typically about 35 kPa (5.0 psi) lower than the inlet pressure. If flow or reversal of flow occurs, the relief valve, which activates on a differential pressure measurement, will open and discharge in order to maintain the zone between the check valves at least 14 kPa (2 psi) lower than the supply pressure. When normal flow resumes, the relief valve closes as the differential pressure resumes. The relief valve discharge is potentially hazardous material. The design of a facility takes that potential discharge into account.

Reduced pressure backflow prevention assemblies are used in different configurations. In one standard configuration, the inlet and outlet are in line. Another common configuration is an angle pattern in which the inlet to the assembly is vertical up and the outlet is vertical down.

b. Installation

Reduced pressure backflow prevention assemblies are installed, or designed to be installed, with a minimum of clearance of 305 mm (12 in) between the discharge port of the relief valve and the floor grade. The assemblies

need to be installed in a location where testing and maintenance can be performed. Situations that could result in excessive pressure are eliminated. These situations include thermal water expansion and/or water hammer. Local plumbing codes are reviewed for specific installation requirements. Some codes prohibit vertical installation. Materials of construction are typically limited. Reduced pressure backflow prevention assemblies are normally used for potable water applications. Typical characteristics and materials of construction for the assemblies are presented in Table 11-2.

11-7. Static Mixers

Static mixers provide a means of in-line rapid mixing for chemical addition or the combination of two liquid streams. As opposed to conventional rapid mixers, such as turbines and hydraulic jumps, static mixers have no moving parts. This characteristic makes the static mixer a low maintenance alternative for rapid mixing.

a. Design Requirements

Static mixers are generally customized to meet the requirements of each application. Five parameters are

evaluated in the design of a static mixer system: the materials of construction, the size of the pipe, the head loss requirements for the mixer, the number of mixing elements, and the quality of mixing to be achieved.

b. Materials of Construction

Common materials used for static mixers include stainless steel, carbon steel, polyvinyl chloride (PVC), reinforced fiberglass, polytetrafluoroethylene (PTFE) and polyvinylidene fluoride (PVDF). The materials available are dependent upon the manufacturer, and some manufacturers offer additional material options for specific applications.

In choosing the appropriate materials, the requirements of both the static mixer's housing and the mixing elements are accommodated. By combining materials, one can produce a static mixer which provides both chemical resistance and structural strength to the static mixer housing and mixing elements. See Appendix B for material compatibility with fluids.

Static mixers are commonly built from standard diameter piping. Available pipe diameters vary by manufacturer; however, common pipe diameters start at 20 mm (¾ in).

Table 11-2 Typical Reduced Pressure Backflow Prevention Assembly	
Characteristic/Parts	Rating/Material
Assembly Body	Bronze, ASTM B 584-78
Relief Valve Body	Bronze, ASTM B 584-78
Seat Disc	Nitrile, ASTM D 2000 or Silicone
Diaphragm	Nitrile, fabric reinforced
Springs	SS, 300 series options
End Connections	Threaded, ASME B1.20.1
Maximum Working Pressure	1.2 MPa (175 psi)
Fluid Temperature Range	0EC to 60EC (32EF to 140EF)
Source: CMB Industries, FEBCO Backflow Prevention, Reduce Pressure Assembly for High Hazard Service, Model 825Y, vendor bulletin.	

c. Pressure Loss

The end connections available for static mixers include ends prepared for welding, threaded NPT ends, and flanged ends of various classes. Both the pipe diameter and end connections are typically designed to match the process piping system used. However, the diameter of mixer housing can be sized based on the pressure drop available, or desired, if the application requires.

Whereas mechanical mixers require energy to drive the mixing motor, static mixers obtain their required energy the velocity of the fluids being mixed. Thus, every static mixer will have a resulting pressure drop. The pressure drop through the static mixer is dependent upon the flow rate through the static mixer, the specific gravity and viscosity of the fluids being mixed, the diameter of the mixer housing, and the friction loss attributable to the mixing elements. Each manufacturer has sizing equations and/or flow coefficients that are specific for their product. Although the sizing calculations are reviewed to ensure that correct parameter values are used, the specifications place performance requirements on the mixer manufacturer.

d. Configuration

The number of mixing elements effects the quality of mixing achieved, the length of the mixer, and the head loss requirements of the mixer. Factors which affect the number of mixing elements required include the flow regime, the difference in viscosities of the fluids being mixed, the volumetric ratio of the fluids being mixed, the method of injection, and the miscibility of the fluids. Different manufacturers produce mixing elements in different configurations. The different element configurations produce varying mixing results, and estimates on the number of elements required are best obtained by contacting the static mixer manufacturer.

The quality of mixing achieved by a static mixer is often discussed in terms of homogeneity. Homogeneity refers to how closely the combined fluid resembles a homogeneous mixture after passing through a static mixer. Homogeneity is often expressed as a percentage standard deviation from the mean, and is determined by sampling for the desired mixing parameter (concentration, temperature, conductivity) and determining the mean and standard deviation of the samples. Required homogeneity is application specific,

and manufacturers can best determine the number of mixing elements required to achieve the desired homogeneity.

Additional considerations for the design of a static mixer include the number and location of injection ports and the method of chemical injection. The location, connection type and size of injection ports can be customized to match each application. Several types of injection quills are available, as options and specifications vary from manufacturer to manufacturer. It is advisable to contact static mixer manufacturers to determine what selections may suit the desired application and the reasons for recommendation of those options. The contract drawings and specifications are then coordinated to reflect acceptable alternatives.

11-8. Expansion Joints

Expansion joints are used to absorb pipeline expansion typically resulting from thermal extensions. The use of expansion joints is often required where expansion loops are undesirable or impractical. However, expansion joints are not used for direct buried service. Expansion joints are available slip-type, ball, and bellows configurations.

a. Slip-Type Expansion Joints

Slip-type expansion joints have a sleeve that telescopes into the body. Leakage is controlled by packing located between the sleeve and the body. Because packing is used, a leak-free seal is not assured. Properly specified, these expansion joints do not leak; however, because packing is used, these expansion joints should not be used where zero leakage is required. Occasional maintenance is required to repair, replace, and replenish the packing. Slip-type joints are particularly suited for axial movements of large magnitude. They cannot, however, tolerate lateral offset or angular rotation due to potential binding. Therefore, pipe alignment guides are necessary with slip-type expansion joints.

b. Ball Expansion Joints

Ball expansion joints consist of a socket and a ball, with seals placed in between the two parts. Ball expansion joints can handle angular and axial rotation; however, they cannot tolerate axial movements.

c. Bellows Expansion Joints

Bellows expansion joints can be metallic or rubber in material of construction. They do not have packing. These joints typically have bellows, or corrugations, that expand or contract as required to absorb piping expansion. End connections can be welded and/or flanged. Bellows expansion joints can adjust to lateral offset and angular rotation as well as to axial movements. However, they are not capable of handling torsional movement. In order to provide this flexibility, metal bellows are typically much thinner than the associated piping and are subject to over-pressure failure. Metal fatigue due to the cyclic life of the bellows is another factor that must be included in the design.

For example, a typical method to select and size a bellows expansion joint is as follows:

Step 1. Determine the basic type required by the piping system:

- standard without reinforced corrugations (non-equalizing);
- standard with reinforced corrugations (equalizing rings);
- hinged (single plane angular movement only);
- gimballed (multiple plane angular movement only);
- tied (lateral movement only);
- balanced (axial and lateral movement only);
- or other.

Step 2. Determine the body requirements of the expansion joint:

- maximum system pressure and temperature;
- internal diameter equal to the inner diameter of the pipe (D_i);
- end connections (flanged, welded end, combinations, or other);
- material of construction for bellows and sleeves, if required (select material based on application, see Appendix B and Table 11-3, Material Temperature Ranges);
- external body cover, if required (damage protection, insulation application).

Step 3. Calculate the maximum movements (contraction and expansion) to be absorbed by the expansion joint (see previous chapters for thermal expansion).

Step 4. Determine the expansion joint performance requirements and the required bellows configuration:

- calculate the required cycle life, for example, assume a process is anticipated to undergo 2 on-off cycles per week and a 10 year process life is desired

$$\left(\frac{2 \text{ process cycles}}{\text{week}} \right) \left(\frac{52 \text{ weeks}}{\text{year}} \right) (10 \text{ years})$$

= 1,040 cycles required

(note that a manufacturer's standard warranty is 2,000 cycles for axial movement with cycle life is increased to 7,000 if the expansion joint sized for movement = 75% expansion joint rating²);

- select the number of corrugations from manufacturers' data (function of corrugation size, wall thickness, amount of movement, and design cycle life, see Table 11-4);

- determine whether an internal sleeve is required. Sleeves are recommended when

D # 150 mm (6 in) and V > 0.02 m/s per mm diameter (1.66 ft/s per inch diameter),

and when

D > 150mm (6 in) and V > 3 m/s (10 ft/s);

where:

D = nominal pipe size, mm (in)

V = fluid velocity, m/s (ft/s).³

11-9. Piping Insulation

Liquid process piping often has to be insulated when potential heat loss from piping cannot be tolerated in the process, freezing potential exists, or protection of personnel from hot piping is required. CEGS 15080, Thermal Insulation for Mechanical Systems, is used for engineering information and construction requirements.

² ADSCO Manufacturing LLC, Expansion Joints Cat. 1196.

³ Ibid.

Table 11-3 Material Temperature Ranges	
Material	Acceptable Temperature Range
304 Stainless Steel	-185EC to 815EC (-300EF to 1,500EF)
316 Stainless Steel	-185EC to 815EC (-300EF to 1,500EF)
321 Stainless Steel	-185EC to 815EC (-300EF to 1,500EF)
347 Stainless Steel	-185EC to 815EC (-300EF to 1,500EF)
Aluminum	-198EC to 204EC (-325EF to 400EF)
Nickel 200	-156EC to 315EC (-250EF to 600EF)
Inconel 600	-156EC to 649EC (-250EF to 1,200EF)
Inconel 625	-156EC to 649EC (-250EF to 1,200EF)
Monel 400	-156EC to 815EC (-250EF to 1,500EF)
Incoloy 800	-156EC to 815EC (-250EF to 1,500EF)
Incoloy 825	-156EC to 538EC (-250EF to 1,000EF)
Source: ADSCO Manufacturing LLC, Expansion Joints Cat 1196	

Table 11-4 Typical Manufacturers' Data List		
Size, in	Number of Convolutions	Total Axial Movement, in
4	1	7/16
	2	7/8
	3	1-5/16
	4	1-3/4
	5	2-3/16
	6	2-5/8
	7	3-1/16
	8	3-1/2
	9	3-15/16
	10	4-3/8
Source: ADSCO Manufacturing LLC, Expansion Joints Cat. 1196		

In addition, the specification provides guidance on insulation thickness based on pipe size, insulation thermal conductivity or material, and range of temperature service. CEGS 15080 is coordinated with the liquid process piping specification section and contract drawings.

11-10. Heat Tracing

For the purposes of liquid process piping, heat tracing is the continuous or intermittent application of heat to the piping system, including pipe and associated equipment, to replace heat loss. As with insulation, heat tracing is used when potential heat loss from the piping cannot be tolerated by the process or when freezing potential exists. Heat tracing may be accomplished through the use of fluids such as steam, organic/synthetic liquids, and glycol mixtures, or through electrical systems such as self-regulating parallel resistance cable (most common), zone parallel resistance cable, continuous-wattage cables and other methods.

a. Heat Tracing System Selection

The selection criteria for determining the most suitable heat tracing methods include: cost, availability of utilities such as steam or electricity, amount of heat to be provided, area hazardous classification as defined by the National Electric Code (NFPA 70), temperature control requirements and consequence of failure. Economics generally favor electrical heat tracing systems when the piping is less than 300 mm (12 in) in diameter and the temperature to be maintained is 120EC (248EF) or lower. Computer programs are available to assist in selecting the type of system that is most appropriate. In addition, many heat tracing vendors have software available to design a heat tracing system using their products. Typical inputs are piping size and geometry; ambient, process and desired maintenance temperature; control requirements; labor costs and utility rates. Outputs are typically worst case heat loss; a bill of materials for the heat tracing system; and capital, installation and operating costs.