



Valves

Sample Diagrams of Valves and Components



By Ed Hardin, P.E.

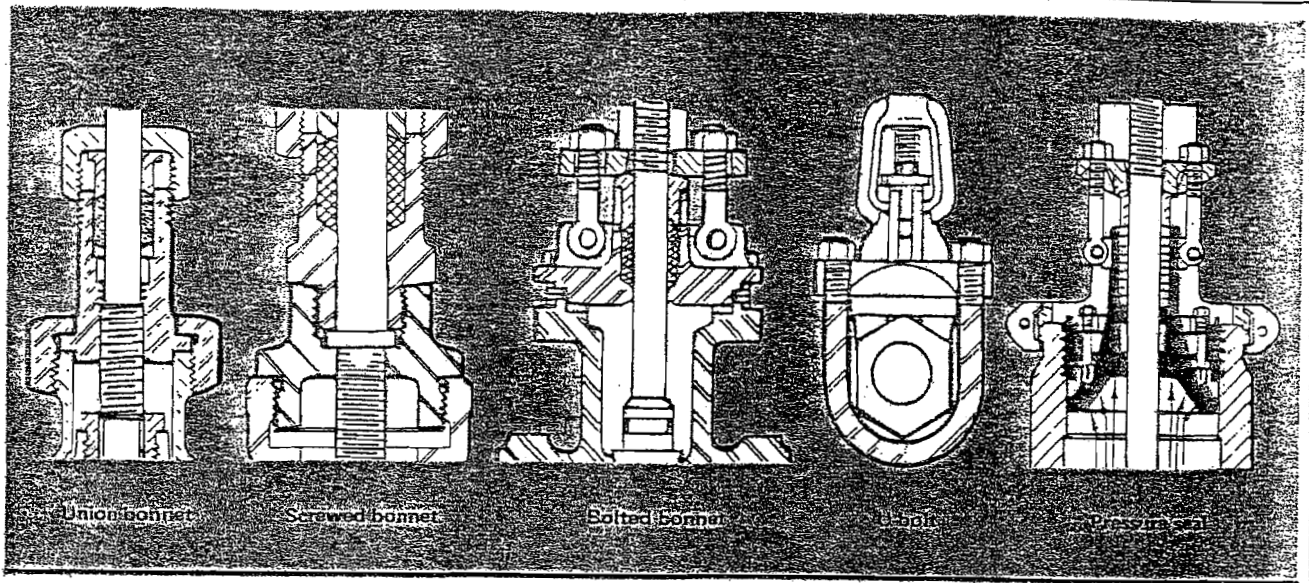

Bonnet variations in various gate-valve types

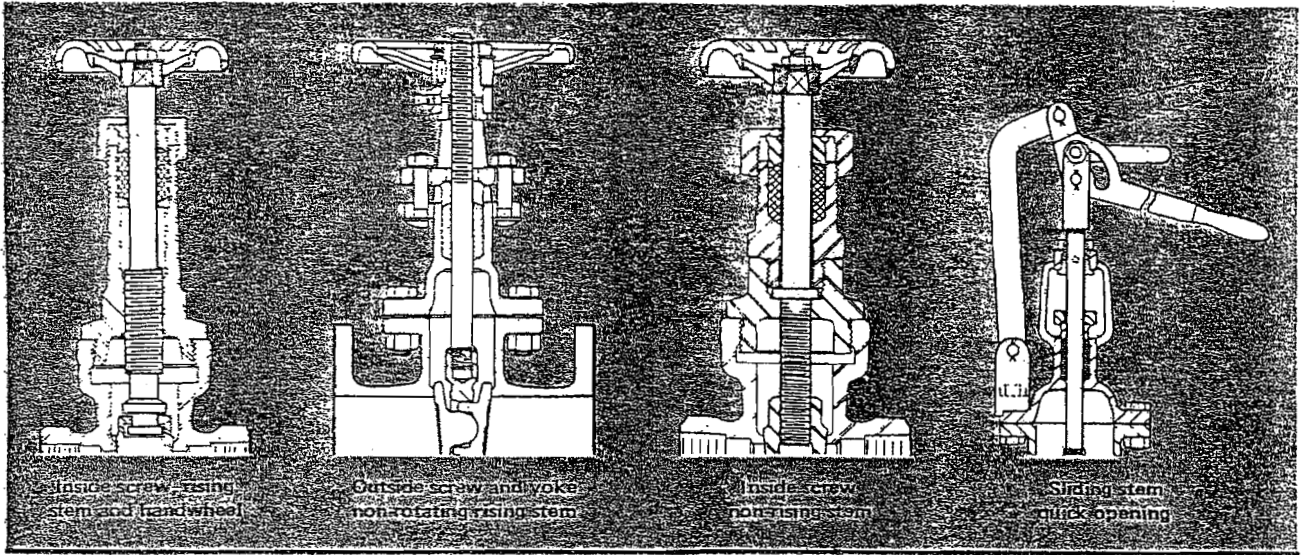

Variations in gate-valve stem mechanisms

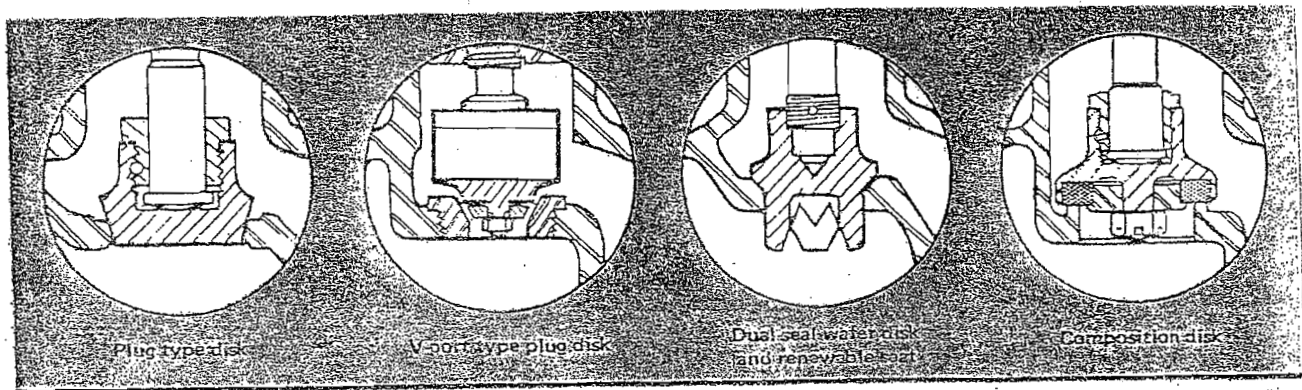

Globe-valve disks of various designs

COMPONENTS OF GATE GLOBE VALVES

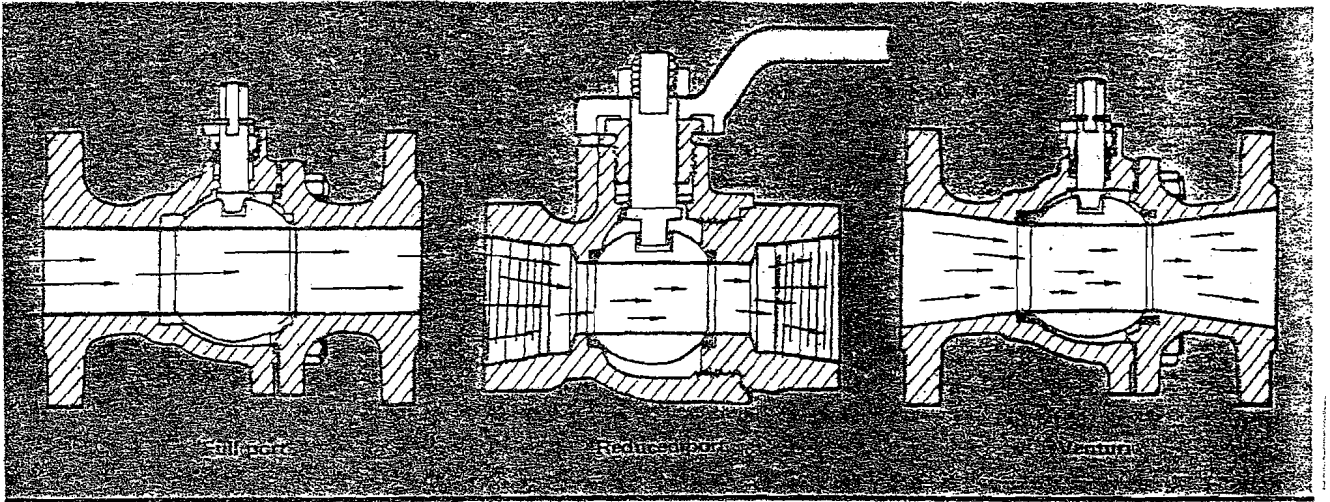

Ball valves: full and, reduced port and venturi types

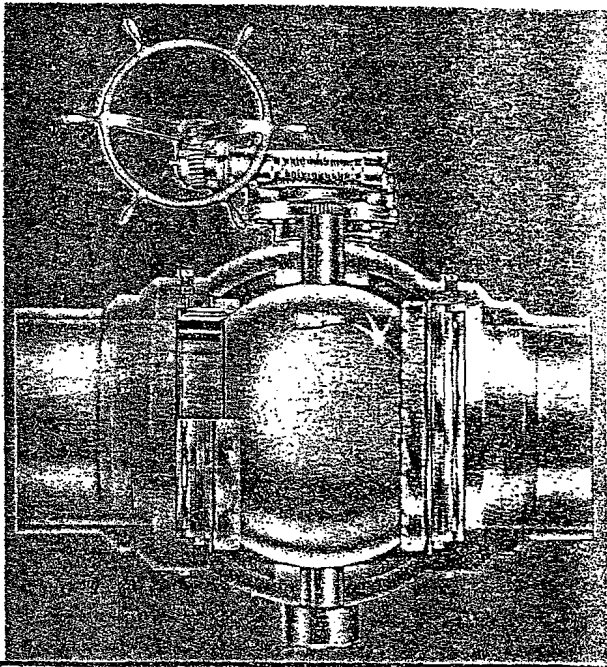

Trunnion-mounted ball valve with rotating seats

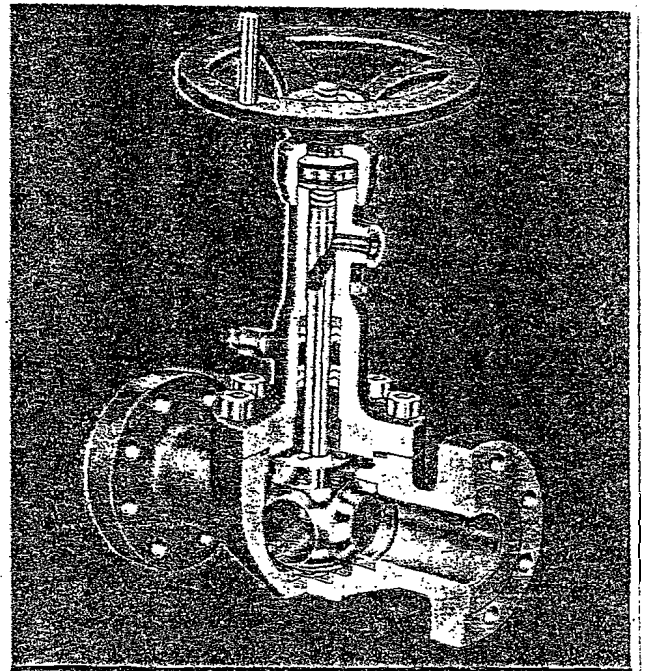

"Rising stem" ball valve has unique actuator

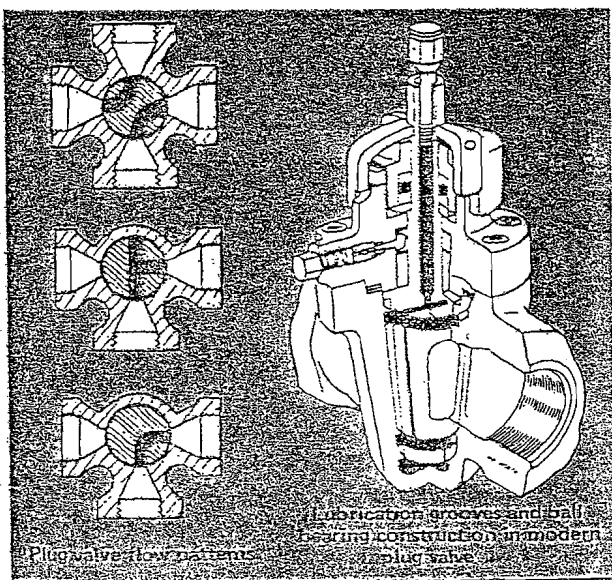

Flow patterns in multiport plug valves

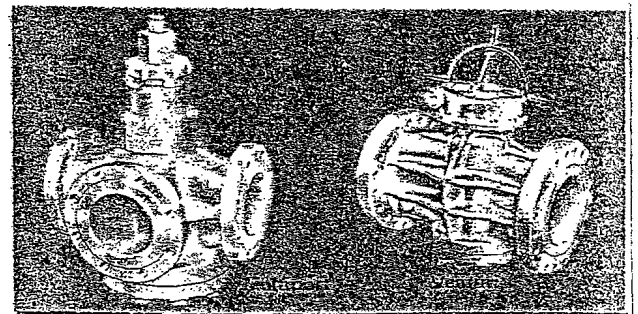

Multiport and venturi varieties of plug valves

BALL & PLUG VALVES

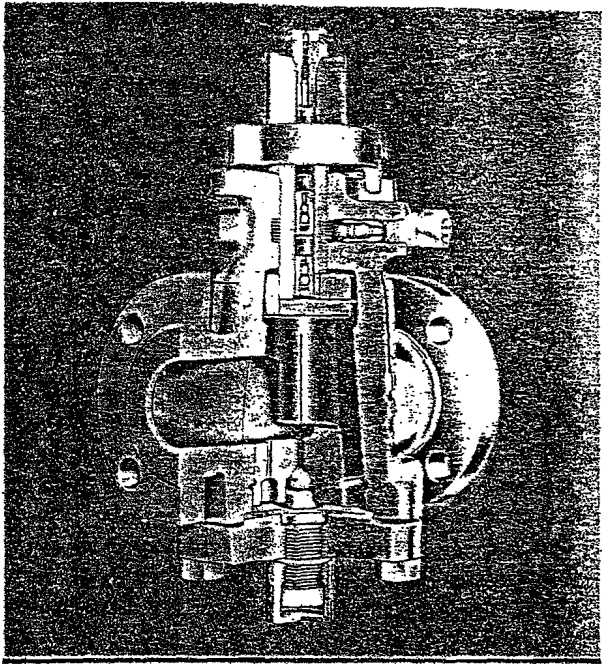

Lubricated plug valve (bolted bottom cover type)

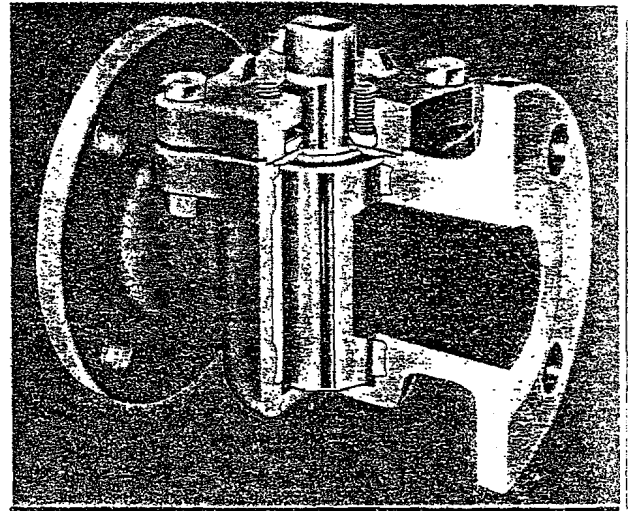

Sleeve-lined nonlubricated plug valve

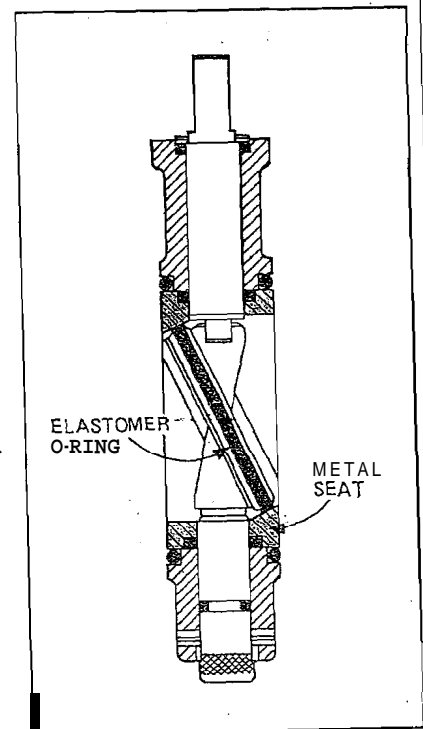
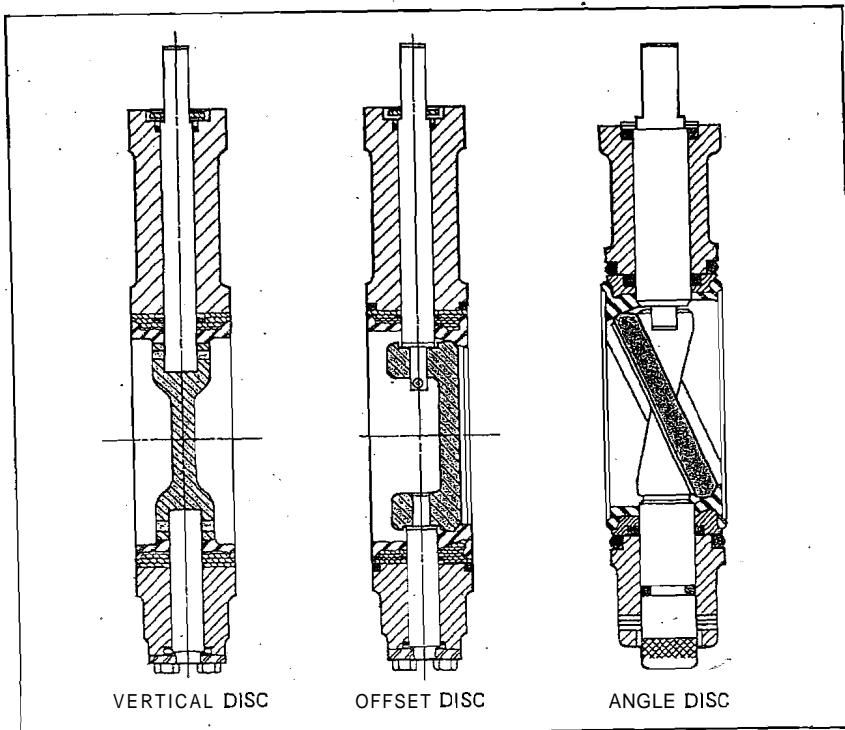

PLUG & BUTTERFLY VALVES

Flow curve : equal percentage

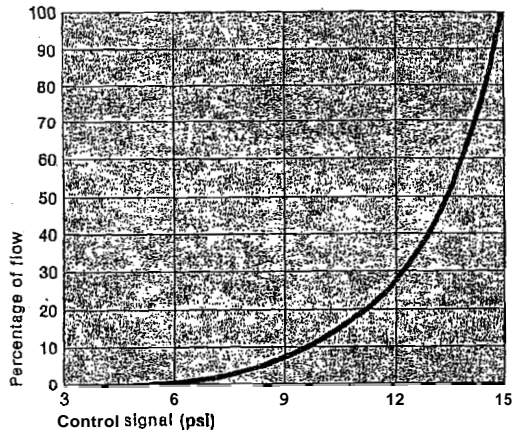
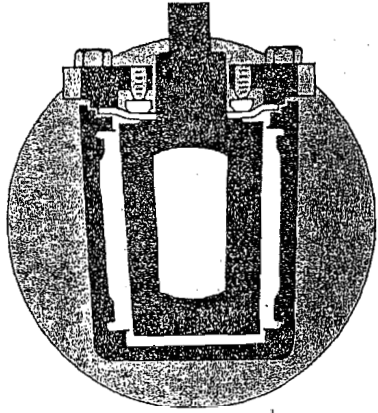

Flow curve : semi-parabolic

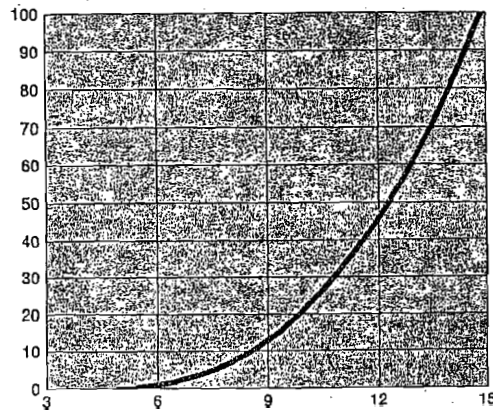
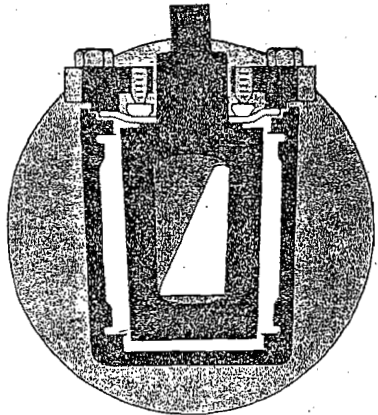

Flow curve : modified linear

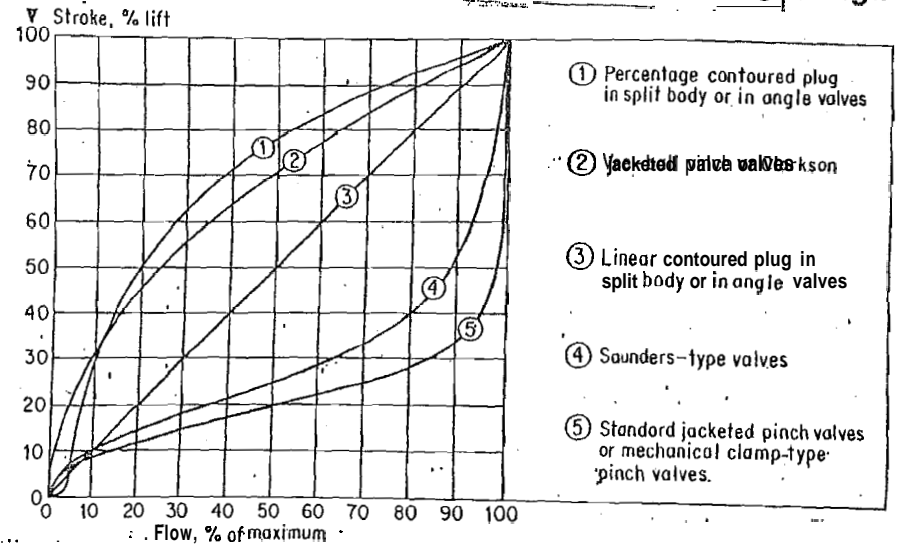
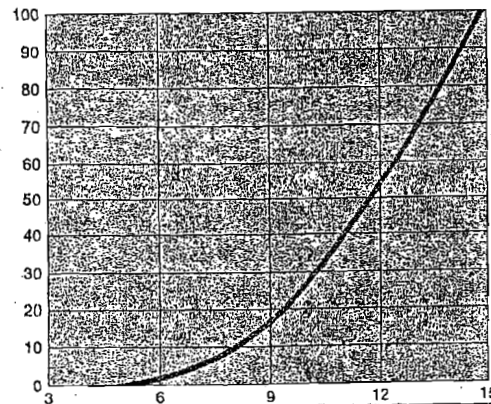
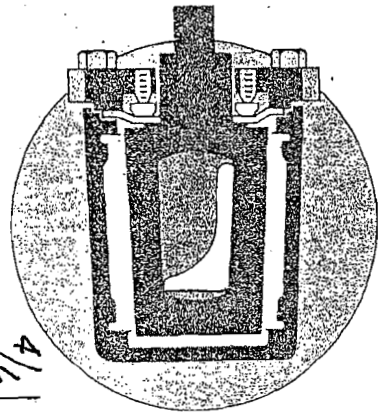

- ① Percentage contoured plug in split body or in angle valves
- ② Jacketed pinch valves
- ③ Linear contoured plug in split body or in angle valves
- ④ Saunders-type valves
- ⑤ Standard jacketed pinch valves or mechanical clamp-type pinch valves.

Standard flow characteristics

Other flow characteristics and CV's are available in both the cage and plate designs.

4/6

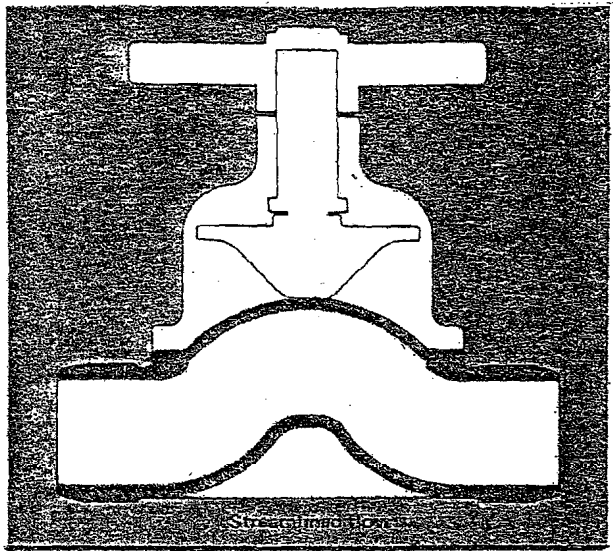

Weir-style (Saunders patent) diaphragm valve

DIAPHRAGM (Saunders-Type)

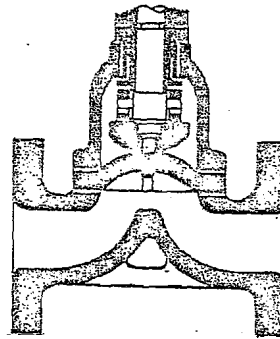

Weir pattern

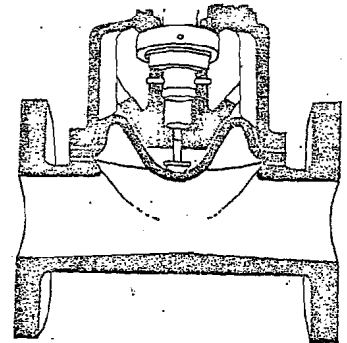

Straightway pattern

PINCH

Mechanical operator

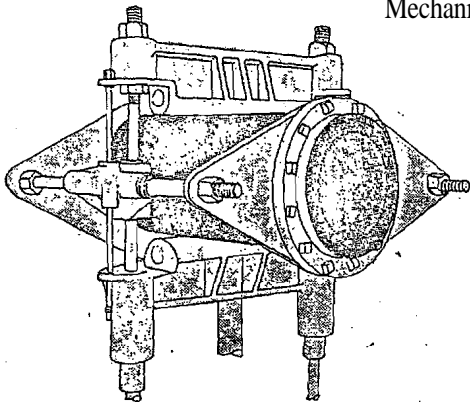

Fluid-force operator

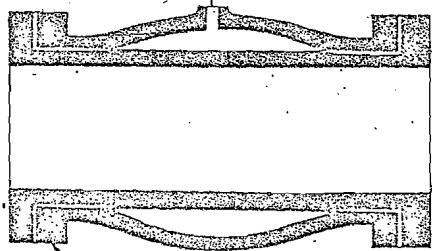
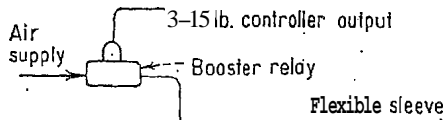

Metallic jacket

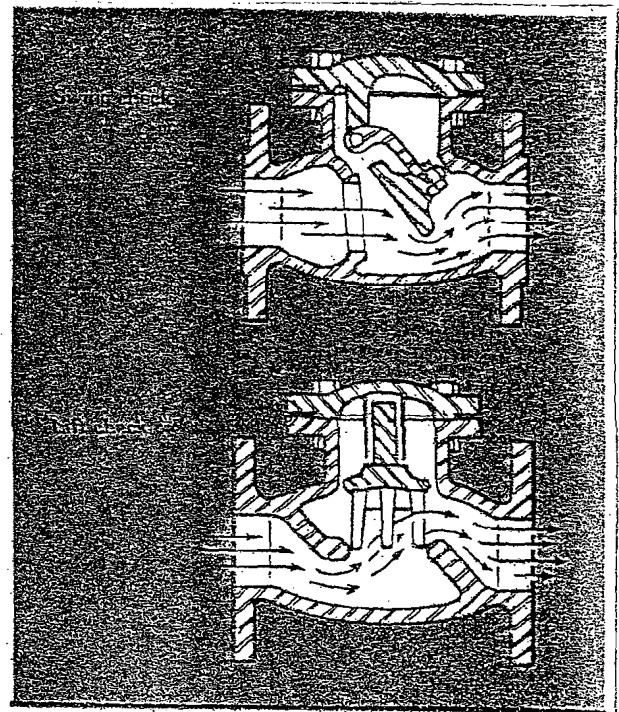
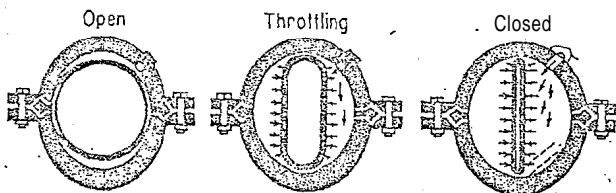

Check valves of swingcheck and lift-check types

SPECIAL VALVES

MISCELLANEOUS

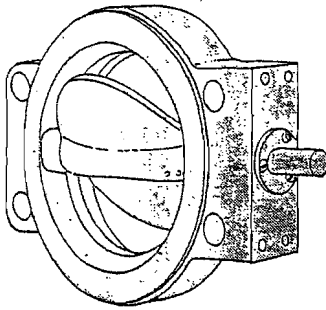

Standard butterfly

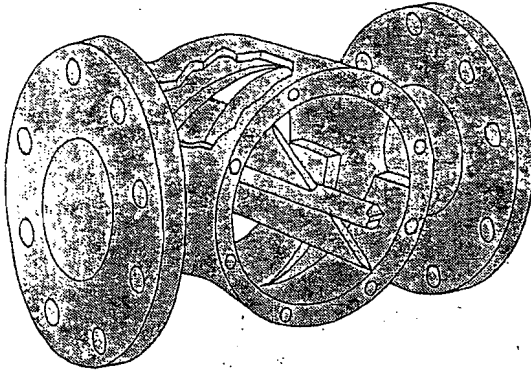

"V"-port butterfly

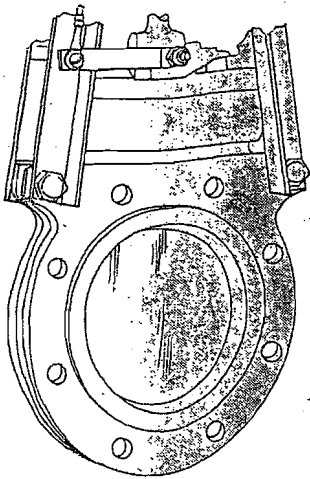

Standard slide gate

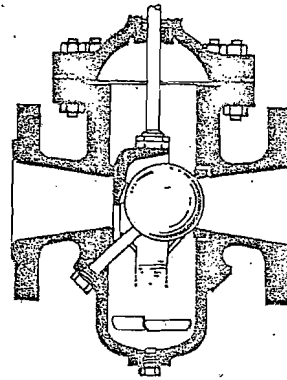

Ball valve with cage holder

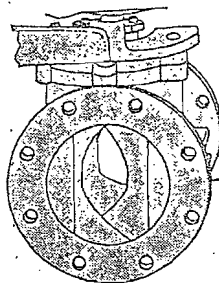

"V"-port plug valves

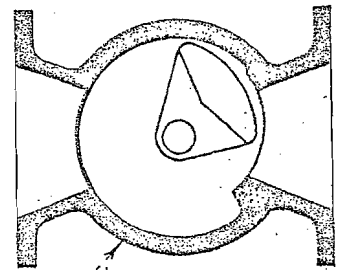

Variable-orifice slide gate

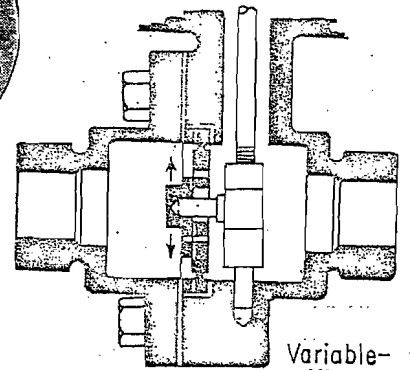

"V"-orifice slide gate

VEE-BALL

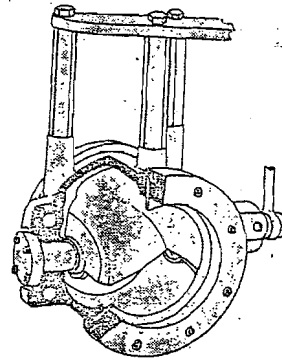

SPECIAL VALVES

6/6

Annular-sleeve slide valve

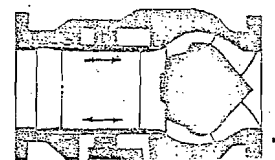

ANGLE

