



PDHengineer.com

Course № O-5003

Centrifugal Pump Analysis for Petroleum Applications



This document is the course text. You may review this material at your leisure before or after you purchase the course. If you have not already purchased the course, you may do so now by returning to the course overview page located at:

<http://www.pdhengineer.com/pages/O-5003.htm>

(Please be sure to capitalize and use dash as shown above.)

Once the course has been purchased, you can easily return to the course overview, course document and quiz from PDHengineer's My Account menu.



If you have any questions or concerns, remember you can contact us by using the Live Support Chat link located on any of our web pages, by email at administrator@PDHengineer.com or by telephone toll-free at 1-877-PDHengineer.

Thank you for choosing PDHengineer.com.



17350 State Highway 249 | Suite 140 | Houston, TX 77064

Centrifugal Pump Analysis

E. Shashi Menon, P.E.

PDHengineer.com Online Course

Revised 30 March 2009

1. Introduction

Centrifugal pumps are used to increase pressure in a liquid for the purpose of transporting the liquid through piping and other devices for use in an industrial process. With the higher pressure, the liquid can be transported in short or long pipelines for delivery to an ultimate destination. Examples include water pipelines, refined petroleum and crude oil pipelines.

The pressure generated by the pump is gradually depleted as the liquid flows through the pipeline, due to friction in the pipe, as well as any elevation increase from the point of origin to the destination point. The liquid as it enters the pump has a certain amount of energy, due to its initial pressure (pressure energy), position (potential energy) and its velocity (kinetic energy). The potential energy depends on the location of the liquid from some datum, such as sea level. The kinetic energy is due to the motion of the liquid. The sum of three components is the total energy of the liquid. As the liquid comes out of the pump, energy is imparted by the rotating element (impeller) in the pump and the liquid pressure increases. The velocity of the liquid also changes from that at the pump inlet. In a centrifugal pump, the liquid is accelerated by centrifugal force during its passage through the rotating pump impeller and finally at the exit, the kinetic energy is converted to pressure energy as it exits the pump volute into the discharge piping.

This is demonstrated in Figure 1. Also shown on the right side of this figure is a cut-away view of a centrifugal pump coupled to an electric motor driver.

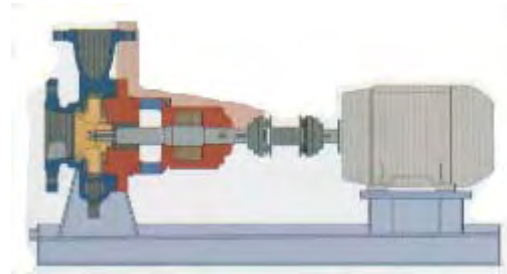
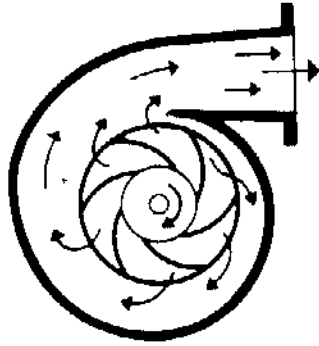

Figure 1 - Centrifugal Pump

2. Types of pumps

In addition to centrifugal pumps, other types of pumps used in the industry include reciprocating and rotary pumps. These are also called positive displacement (PD) pumps, since they provide a constant volume displacement, regardless of the pressure generated. Centrifugal pumps on the other hand, provide variable flow rates over a range of pressures. Rotary pumps include gear pumps and screw pumps used with high viscosity liquids. Examples of these pumps are shown in Figure 2

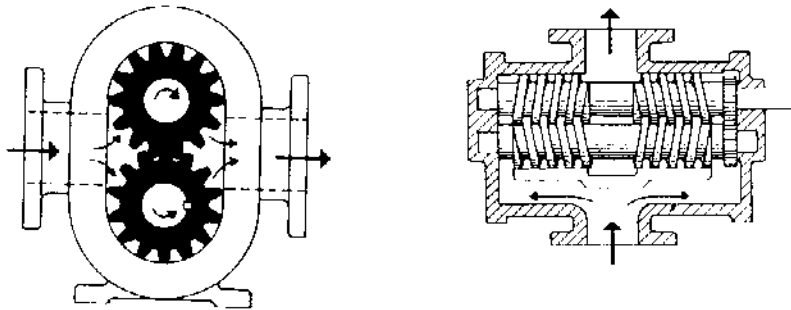

Figure 2 - Gear Pump and Screw Pump

Most pipelines transporting water and petroleum products today use centrifugal pumps due to their flexibility in flow rates and pressures. Also, their maintenance cost is less compared to PD pumps. However, PD pumps have better efficiency, compared to centrifugal pumps. In this course we will concentrate only on the performance and applications of centrifugal Pumps.

Centrifugal pumps may consist of the following types:

- (a) Radial Flow Pumps
- (b) Axial Flow Pumps
- (c) Mixed Flow Pumps

Radial flow pumps generate pressure purely by centrifugal force of the liquid due to rotation of the pump impeller. Axial flow pumps develop pressure by propelling or lifting the liquid by the pump impeller vanes. Mixed flow pumps use a combination of radial and axial flow pumps. When high heads are required, radial flow pumps are used. Axial flow and mixed flow pumps are generally used with low head - high capacity systems.

Before we delve into the details of centrifugal pumps, it would be appropriate to briefly discuss units of calculations and liquid properties that effect pump performance.

Units

The commonly used units of measurement in the USA are called the English system of units, also referred to as US Customary System (USCS) of units. The metric system of units used in Canada, Mexico, South America, Europe, Asia and Australia more commonly known as the Systeme International (SI) units. We will be using both sets of units throughout this course. In the USCS units, length may be measured in feet or miles. Mass is measured in pounds (lb), flow rate in US gallons per minute (gal/min), cubic foot per second (ft^3/s) or barrels per hour (bbl/hr). Pressure is measured in pounds per square inch (psi) and temperature in degrees Fahrenheit (F).

The corresponding units in SI system are as follows - length in meters (m) or kilometers (km). Mass in kilograms (kg), flow rate in m^3/hr or liters per second (L/s). Pressure in kilopascal (kPa), Megapascal (MPa) or Bar. Temperature in degrees Celsius (C). In addition, pipe diameter is referred to in inches (in.) and millimeters

(mm) in the USCS and SI system respectively. The term head used in conjunction with liquid pressure is stated in units of ft in USCS and m in SI system.

Liquid Properties

The following liquid properties are important in the analysis of centrifugal pump.

Density is the weight per unit volume of liquid at a particular temperature. For water at 60 F, the density is 62.4 lb/ft³.

Specific gravity, a dimensionless number represents the relative weight of the liquid compared to water at the same temperature. It is obtained by dividing the density of the liquid by the density of water. For example the density of diesel is approximately 53 lb/ft³ compared to 62.4 lb/ft³ for water at 60 F. Therefore, the specific gravity of diesel at 60 F is as follows:

$$\text{Spgr} = 53 / 62.4 = 0.85 \text{ at } 60 \text{ F}$$

The density and specific gravity of a liquid decrease with increase in temperature.

Specific gravity and viscosity (discussed later) of some common liquids are as shown in Table 1.

Table 1 - Properties of Common Liquids

Product	Specific Gravity	Viscosity
	@ 60°F	cSt @ 60°F
Water	1.0000	1.00
Gasoline	0.7350	0.60
Diesel	0.8500	5.00
Kerosene	0.7796	2.17
Jet Fuel JP-4	0.7711	1.40
No.1 Fuel Oil	0.8155	2.57
No.2 Fuel Oil	0.8392	3.90

Another term related to specific gravity that is used in connection with petroleum products is degrees API gravity. The API scale of measurement is based on an API gravity of 10 for water. The API scale is such that as the liquid gets lighter (lower specific gravity) the API value increases, due to its reciprocal relationship with specific gravity discussed next. The API gravity is always measured at 60 F and is related to the specific gravity at 60 F by the equation

$$\text{API} = 141.5/\text{Sg} - 131.5 \quad (2.1)$$

For example the API gravity of diesel with a specific gravity of 0.85 at 60 F is calculated as follows:

$$\text{API} = 141.5/0.85 - 131.5 = 34.97$$

Also, substituting $\text{Sg} = 1.0$ for water in Equation (2.1) confirms the value of API = 10 for water. The other important property of liquids related to centrifugal pumps is viscosity, discussed next.

Viscosity of a liquid represents the resistance to flow and is defined by Newton's equation that relates the shear stress in the liquid to the velocity gradient of flow. When liquid flows through a pipeline the velocity (or speed) of liquid particles at any cross-section varies in some fashion depending upon the type of flow (laminar or turbulent) Generally the particles close to the pipe wall will be at rest (zero velocity) and as we move towards the center of the pipe the velocity increases. The velocity variation may be considered to be approximately trapezoidal for turbulent flow or close to a parabola for laminar flow. Considering one half cross section of the pipe the liquid velocity u varies from zero to a maximum of u_{\max} . If the distance measured from the pipe wall to a point within the pipe cross section is y , the velocity

gradient is du/dy . This is depicted in Figure 3. Laminar flow occurs at low flow rates and hence low velocities. As the flow rate and velocity increase, the flow becomes turbulent.

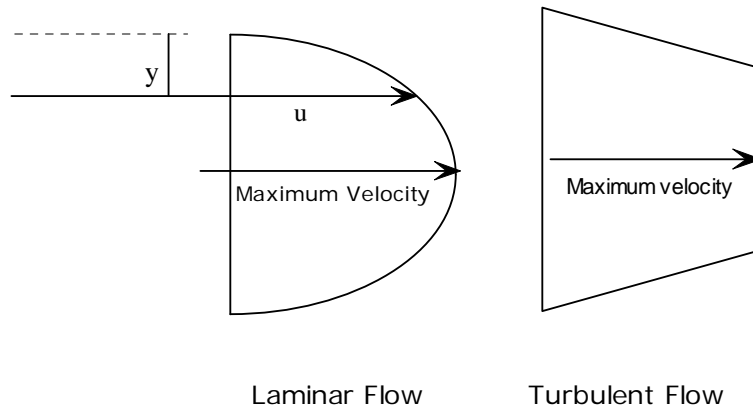

Figure 3 - Velocity variation in pipe flow

Newton's Law states that the shear stress τ between successive layers of liquid is proportional to the velocity gradient du/dy . The constant of proportionality is known as the dynamic or absolute viscosity of liquid μ .

$$\tau = \mu \, du/dy \tag{2.2}$$

The absolute viscosity is measured in lb/ft-s in USCS units and in Poise (P) or centipoise (cP) in SI units. A related term known as the kinematic viscosity, denoted by ν is defined as the ratio of the absolute viscosity μ to the liquid density ρ at the same temperature.

$$\nu = \mu / \rho \tag{2.3}$$

In USCS units ν is stated in ft^2/s and in SI units, it is expressed in m^2/s , Stokes (S) or centistokes (cSt). Water has an approximate viscosity of 1.0 cP or 1.0 cSt at 60 F. In comparison, Alaskan North Slope (ANS) crude oil has a viscosity of 43 cSt at 60 F.

When dealing with petroleum products, kinematic viscosity in cSt is used in both USCS and SI units. However, in testing petroleum products in the laboratory, kinematic viscosity is also sometimes stated in units of SSU or SSF. SSU stands for Saybolt Seconds Universal and SSF is for Saybolt Seconds Furol. SSU is used for heavy crude oils and SSF for heavy fuel oils. For example, the viscosity of ANS is 200 SSU at 60 F. Viscosity conversion from SSU and SSF to cSt and vice versa can be done using the following formulas.

$$\text{cSt} = 0.226(\text{SSU}) - 195/(\text{SSU}) \quad (2.4)$$

for $32 \leq \text{SSU} \leq 100$

$$\text{cSt} = 0.220(\text{SSU}) - 135/(\text{SSU}) \quad (2.5)$$

for $\text{SSU} > 100$

$$\text{cSt} = 2.24(\text{SSF}) - 184/(\text{SSF}) \quad (2.6)$$

for $25 < \text{SSF} \leq 40$

$$\text{cSt} = 2.16(\text{SSF}) - 60/(\text{SSF}) \quad (2.7)$$

for $\text{SSF} > 40$

For example, a viscosity of 200 SSU can be converted to cSt as follows, from Equation (2.5)

$$\text{cSt} = 0.220 \times 200 - 135/200 = 43.33$$

Similarly, viscosity of 200 SSF can be converted to cSt as follows, from Equation (2.7)

$$\text{cSt} = 2.16 \times 200 - 60/200 = 431.7$$

It can be observed from equations above that converting kinematic viscosity from SSU and SSF into cSt is fairly easy. However, to convert from cSt to SSU or SSF is not straight forward. You will have to solve a quadratic equation. This will be

illustrated using an example. A rule of thumb is that the SSU value is approximately 5 times the cSt value.

Example 1

Convert a viscosity of 150 cSt to SSU.

Assuming the viscosity in SSU will be approximately $5 \times 150 = 750$, we can then use equation 2.5 as follows

$$150 = 0.220 \times \text{SSU} - 135/\text{SSU}$$

Transposing we get a quadratic equation in SSU

$$0.22x^2 - 150x - 135 = 0$$

Where x is viscosity in SSU

Solving for x, we get $x = 682.72$ SSU

Similar to density and specific gravity, the viscosity of a liquid decreases with increase in temperature. However, the variation is not linear. Generally, from laboratory data, the viscosity of a crude oil or petroleum product is reported at two different temperatures. From this data, a plot of viscosity versus temperature can be made on a special graph paper known as ASTM D341. Once we plot the pair of points, the viscosity at any intermediate temperature can be determined by interpolation.

The **specific heat** of a liquid is defined as the heat required to raise the temperature of a unit mass of liquid by one degree. For example, the specific heat of petroleum products ranges from 0.4 to 0.5 Btu/lb/F. It is used in calculating the temperature rise of a liquid being pumped.

Vapor Pressure of a liquid is defined as that pressure at a certain temperature when the liquid and its vapor are in equilibrium. Consequently, the boiling point of a liquid is the temperature at which its vapor pressure equals the atmospheric pressure. In a laboratory, the liquid vapor pressure is generally measured at 100 F and referred to as the Reid Vapor Pressure (RVP). The vapor pressure of a liquid increases with increase in temperature. Therefore if the Reid Vapor pressure of a liquid 10.0 psig, the vapor pressure at 70 F will be a lower number such as 8.0 psig. The actual vapor pressure of a liquid at any temperature may be obtained from charts, knowing its Reid vapor pressure. The vapor pressure of a liquid is important in determining the minimum suction pressure available for a centrifugal pump. This is discussed in further detail under NPSH calculations for centrifugal pumps.

Pressure and head of a liquid

Pressure at any point in a liquid depends upon the depth below the free surface of the liquid and is measured using a pressure gauge in psig (pounds per square inch gauge). Consider a tank containing a liquid at rest with its free surface open to the atmosphere. At a depth of h ft below the liquid surface the pressure in all directions is the same. This is known as Pascal's Law. The pressure increases linearly with depth and can be calculated using the formula

$$\text{Pressure (in psig)} = h \times Sg / 2.31 \quad (2.8)$$

Where Sg represents the liquid specific gravity.

The corresponding equation for SI units is

$$\text{Pressure (kPa)} = h \times Sg / 0.102 \quad (2.9)$$

Where h is in meters.

It can be seen that the pressure in psi is related to the height of liquid in ft and therefore the term **head** is used for the equivalent pressure. For example, we can convert a head of 1000 ft of liquid to the equivalent pressure in psi knowing the liquid specific gravity as follows:

$$\text{Pressure} = 1000 \times 1.0 / 2.31 = 432.9 \text{ psi for water (Sg} = 1.00)$$

$$\text{Pressure} = 1000 \times 0.895 / 2.31 = 387.45 \text{ psi for ANS crude (Sg} = 0.895)$$

Similarly, a pressure of 600 psi in gasoline (Sg = 0.74) is equivalent to a liquid head of $600 \times 2.31 / 0.74 = 1873$ ft. Thus, we can calculate the pressure in psi for a given liquid head in ft and vice versa.

Even though we should strictly refer to pressure in psig, since all pressures are measured with a gauge with respect to the atmospheric pressure, psi will be used interchangeably with psig throughout this course.

Example 2 (SI units)

The discharge pressure of a pump is 5500 kPa. What is the liquid head assuming specific gravity of 0.815.

Solution

Using Equation 2.9

$$5500 = h \times 0.815 / 0.102$$

$$h = 688.34 \text{ m}$$

3. Pump Characteristics

The performance of a centrifugal pump is represented graphically by a series of curves. These curves show how the pump pressure and efficiency vary with the flow rate through the pump. The pressure developed is usually referred to in feet of head, rather than psi or kPa. The flow rate is more commonly known as the **capacity** of the pump. Each pump has characteristic performance curves, depicting these variations, as shown in Figure 4

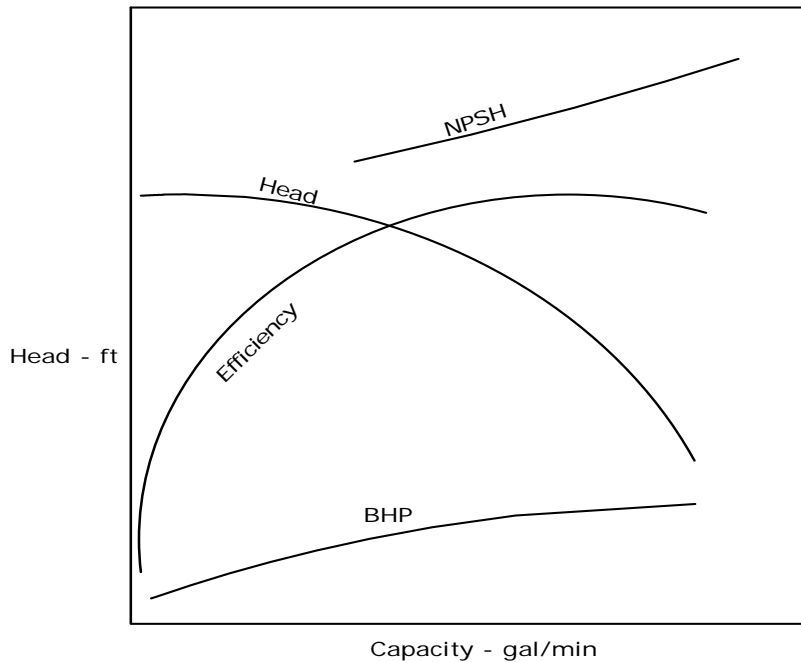

Figure 4 - Centrifugal pump performance curves

The pressure generated at a particular flow rate can be referred to in units of pressure (psi in USCS or kPa in SI units) or in units of head. The head in a liquid is equal to the pressure multiplied by a constant and divided by the liquid specific gravity, as we discussed in Equation (2.8), shown here again for convenience.

$$\text{Head (ft)} = \text{Pressure (psi)} \times 2.31 / \text{spgr} \quad (3.1)$$

$$\text{Head (meters)} = \text{Pressure (kPa)} \times 0.102 / \text{spgr} \quad (3.2)$$

Most pump vendors in the USA provide the performance curves for centrifugal pumps in which capacity is in gal/min and the pressure is in ft of head of liquid pumped. Also, all pump curves from vendors catalogs are referred to water as the pumped medium. Since the curves show pump head in feet, it would be the same for all liquids, as long as the viscosities are fairly low (usually less than 10 cSt).

Figure 4 shows typical performance curves of a centrifugal pump as follows:

1. Head in ft versus capacity in gal/min
2. Efficiency(%) versus capacity in gal/min
3. Brake horsepower (BHP) versus capacity in gal/min
4. NPSH versus capacity in gal/min

The head versus capacity curve is also referred to as the H-Q curve, while the efficiency curve is called the E-Q curve.

In addition to the H-Q, E-Q and BHP versus Q curves, the pump vendor also provides a curve labeled NPSH (Net Positive Suction Head) which represents the minimum suction head required for the pump at various flow rates. The NPSH curve is usually plotted above the H-Q and E-Q curves, as in Figure. 4.

From Figure. 4, it can be seen that the H-Q curve of this centrifugal pump is a drooping curve. The head starts off at the highest value and gradually reduces with increase in capacity. The maximum head occurs at zero flow and is called the shutoff head. The trailing point of the H-Q curve shows the maximum capacity this pump can handle and the least head the pump produces at this flow rate. The efficiency

curve gradually rises from zero capacity up to a maximum efficiency and then drops off beyond that capacity. The point on the H-Q curve corresponding to the maximum efficiency is referred to as the Best Efficiency Point (BEP), as shown in Figure 5.

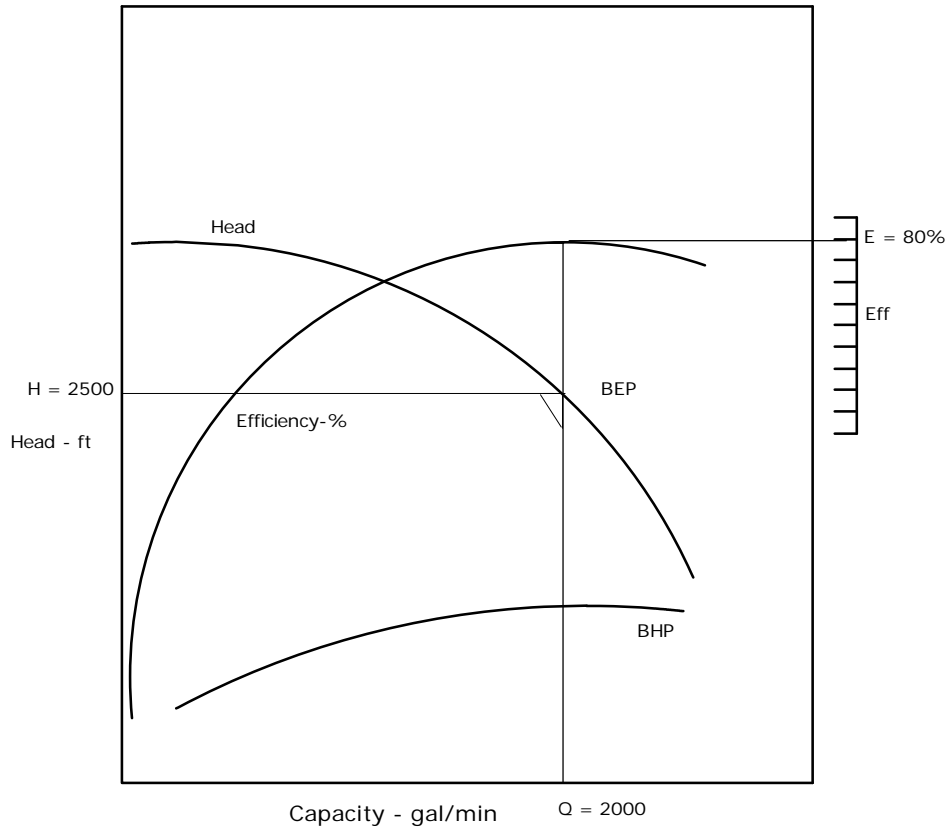

Figure 5 - Best Efficiency Point

Figure 5 shows a pump H-Q and E-Q curves with the BEP at a capacity of 2000 gal/min, 2500 ft head and an efficiency of 80%.

The BHP (discussed in detail later) also increases with increase in capacity. As mentioned before, centrifugal pump performance curves are generally plotted considering water as the liquid pumped. Therefore, the BHP is calculated considering specific gravity = 1.0.

The NPSH curve also increases with increase in flow rate. The term NPSH refers to Net Positive Suction Head and is a measure of the minimum suction head required at the suction of the pump impeller at any flow rate. NPSH is a very important parameter when dealing with centrifugal pumps particularly when pumping volatile liquids. It will be discussed in more detail later.

When increased pressure is required for a particular application, it may be achieved by adding more stages within a pump. Sometimes, for multi stage pumps, the H-Q performance curve may be shown for a single stage. The total performance is computed by multiplying the head per stage by the number of stages, at each flow rate.

Consider the pump in Figure 5 that produces 2500 ft of head at a capacity of 2000 gal/min and has an efficiency of 80% at the BEP. These values are applicable when pumping water or any other low viscosity (less than 10 cSt) liquid. Therefore, regardless of the liquid, this pump will develop 2500 ft of head at 2000 gal/min. However, since water and gasoline have different specific gravity, the actual pressure developed in psi will be different as indicated below.

Pressure developed with water = $2500 \times 1.0 / 2.31 = 1082.25$ psi

Pressure developed with gasoline = $2500 \times 0.735 / 2.31 = 795.45$ psi

In the above we have assumed a specific gravity of 0.735 for gasoline compared to 1.0 for water.

The H-Q curve plotted for a particular pump depends upon the pump impeller diameter as well as the rotational speed of the impeller. Thus the H-Q curve in Figure 5 may be drawn based on the pump impeller speed of 3570 RPM and an impeller diameter of 10 inches.

If the pump speed is increased to 4000 RPM, the H-Q curve will be located above the current curve. Similarly, if the pump were operated at a speed of 3000 RPM the new H-Q curve will be below the current curve. This is illustrated in Figure 6.

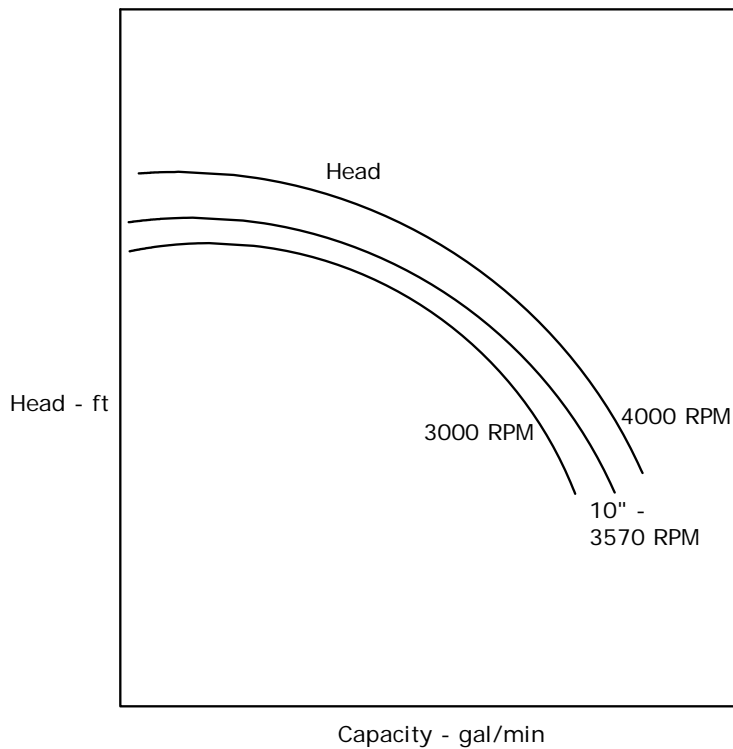

Figure 6 - Head versus Flow Rate at Different Speeds

The variation of the H-Q curve with respect to the impeller diameter for a constant speed also follows a similar pattern. Therefore, compared to a 10 inch impeller curve, the H-Q curve for a 12 inch impeller will be above and the corresponding curve for a 9 inch impeller will be below the 10 inch curve. This is illustrated in Figure 7, which shows a constant speed pump.

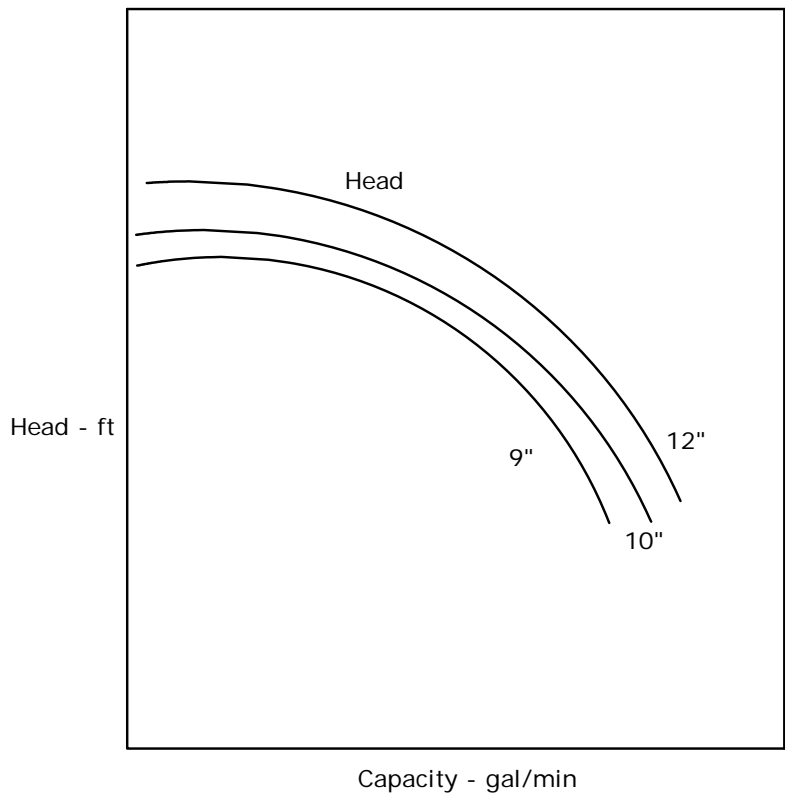

Figure 7 - Head versus Flow Rate at Different Impeller Sizes

We will discuss the variation of pump performance with impeller speed and impeller diameter in more detail, under the section titled Affinity Laws later in this course.

As mentioned earlier, the head generated by a pump also depends upon the number of stages. Depending upon the head requirement for a specific application, additional stages may be needed for a pump. Suppose the total head required is 2000 ft and the pump chosen can develop 400 ft per stage. It can be seen that for this application we will need a five stage (2000/400) pump, for the same impeller size and speed. De-staging and restaging are terms used in connection with multi stage pumps. A five stage pump may produce too much head for an application and therefore may be de-staged to three or four stages to match the lower head requirement. Similarly, a de-staged pump may be restaged from 3 stages to 4 stages to satisfy a higher head requirement, for a future application.

Specific Speed

The specific speed of a centrifugal pump is a parameter used to compare different pump models for different applications, such as low head, high flow etc. The specific speed of a pump depends upon the impeller speed, capacity and the head at the BEP. The specific speed is also defined as the speed that a geometrically similar pump has to be run so that it develops a head of 1 ft at a capacity of 1 gal/min. The formula for specific speed is as follows:

$$N_s = N Q^{1/2} / H^{3/4} \quad (3.3)$$

Where N_s is the specific speed of the pump, N is the impeller speed in RPM, Q is the capacity in gal/min and H is the head in ft at the BEP of the pump.

It is important to remember that the values of Q and H in the above equation correspond to the Best Efficiency Point (BEP) for the maximum impeller diameter of the pump. Also for a multi-stage pump, H is the head per stage of pump. It can be seen from the above equation that high head pumps have low specific speeds. Conversely, low head pumps have high specific speeds.

For the pump shown in Figure 5, assuming a 5 stage pump at 3570 RPM, the specific speed is calculated as

$$N_s = 3570 \times (2000)^{1/2} / (2500/5)^{3/4}$$

$$= 1510$$

The specific speeds of centrifugal pumps range from 500 to 20,000 depending upon the design of the pump as indicated in Table 2

Table 2 Specific Speeds of Centrifugal Pumps

Pump Type	Application	Specific Speed
Radial Vane	Low capacity/high head	500 - 1000
Francis - Screw Type	Medium capacity/Medium head	1000 - 4000
Mixed - Flow Type	Medium to high capacity, low to medium head	4000 - 7000
Axial - Flow Type	High capacity/low head	7000 – 20,000

There is another specific speed parameter for centrifugal pumps, called the *suction specific speed*. This parameter takes into account the NPSH (instead of the head per stage) at the BEP of the pump and is calculated as follows:

$$N_{SS} = N Q^{1/2} / (NPSH_R)^{3/4} \quad (3.4)$$

where N_{SS} is the suction specific speed, N is the impeller speed in RPM, Q is the capacity in gal/min and $NPSH_R$ is the NPSH required at BEP. The terms NPSH required and NPSH available will be discussed later in this course.

It is important to note that the value of Q used in calculating the two specific speeds N_S and N_{SS} for double suction pumps are slightly different. For N_S the full value of Q is used whereas for N_{SS} half the value ($Q/2$) is used for double suction pumps.

Example 3

Calculate the specific speed of a 4-stage double suction centrifugal pump, 10 inch diameter impeller that has a speed of 3570 RPM and develops a head of 2000 ft at a flow rate of 2500 gal/min at the BEP. Calculate the suction specific speed given the NPSH required is 20 ft at the BEP.

Solution

$$\begin{aligned} N_S &= N Q^{1/2} / H^{3/4} \\ &= 3570 (2500)^{1/2} / (2000 / 4)^{3/4} = 1688 \end{aligned}$$

The suction specific speed can be calculated as follows:

$$\begin{aligned} N_{SS} &= N Q^{1/2} / NPSH_R^{3/4} \\ &= 3570 (2500 / 2)^{1/2} / (20)^{3/4} = 13,346 \end{aligned}$$

4. Effect of Liquid Properties on Pump Performance

As mentioned before, the pump performance curves shown in a pump vendor's catalog is based on water. Therefore, the head-capacity curve, efficiency-capacity curve, BHP-capacity curve and NPSH-capacity curve are all shown for water with a specific gravity of 1.0. The BHP depends upon the specific gravity of the liquid and it is calculated from the following formula

$$\text{BHP} = Q \times H \times \text{Sg} / (3960 \times \text{Effy}) \quad (4.1)$$

Where Q is the capacity in gal/min, H is the head in ft and Effy is the efficiency of the pump expressed as a decimal value, less than 1.0.

In SI units the Power in kW is calculated from the following equation

$$\text{Power kW} = Q \times H \times \text{Sg} / (367.46 \times \text{Effy}) \quad (4.2)$$

Where Q is the capacity in m³/hr and H is in meters.

The pump head H at any capacity Q is reported in ft of liquid and hence remains the same regardless of the liquid specific gravity. However, the pressure generated, measured in psi will depend upon the specific gravity as explained in Equation (3.1) earlier. When the liquid pumped is gasoline (specific gravity = 0.735, viscosity = 0.8 cSt), the same head-capacity and efficiency - capacity curves still apply since the difference between the properties of water and gasoline is not very significant. However, when the liquid pumped is a high viscosity crude oil such as ANS with specific gravity = 0.895 and viscosity = 43 cSt, the pump performance will be different from that of water. Generally, as long as the liquid viscosity is below 10 cSt no correction to the pump performance is necessary. At higher viscosities, the pump performance curves must be corrected for viscosity using the Hydraulic Institute

charts. Figure 8 shows such a chart used for correcting the pump performance curves at different viscosity.

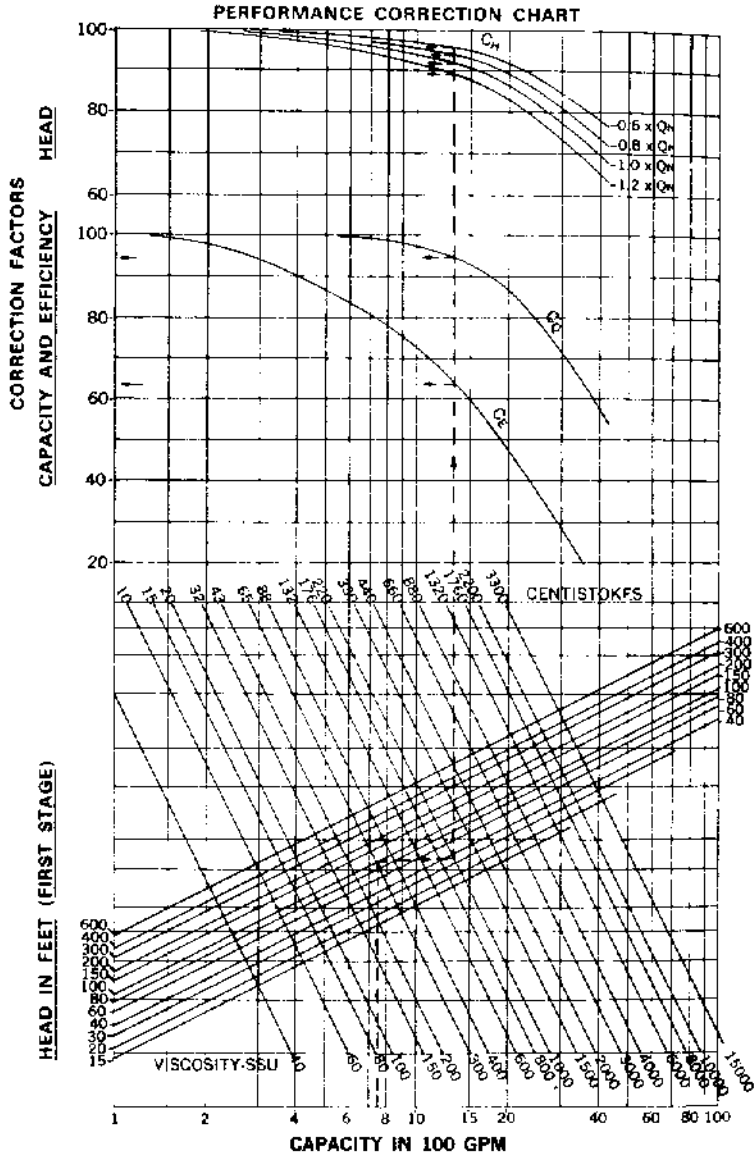

Figure 8 – Viscosity Correction Chart for Pumps

When dealing with pump applications that involve high viscosity (greater than 10 cSt) liquids we must provide the pump vendor with the liquid specific gravity and viscosity data so that the vendor may adjust the water performance curves to the liquid being pumped. An example of correcting the pump performance curves for viscosity, using the Hydraulic Institute chart is explained in the next problem. Commercial software programs are available to perform viscosity correction quickly and easily. One such program is PUMPCALC developed by SYSTEK Technologies, Inc. (www.systemek.us).

Example 4

The performance of a two stage centrifugal pump for water is given below at various flow rates (60%, 80%, 100% and 120% of the BEP flow rate):

Q - gal/min	450	600	750	900
H - ft	228	216	200	172
E - %	72.5	80.0	82.0	79.5

(a) Determine the corrected performance of this pump when pumping crude oil with a specific gravity of 0.9 and a viscosity of 1000 SSU at 60 F.

Solution

(a) It can be seen that the BEP for this pump is at a capacity of 750 gal/min. The BEP values are as follows: $Q = 750$, $H = 200$ and $E = 82$

In order to determine the viscosity corrected performance we must first determine the water performance at the four different capacities that correspond to 60%, 80%, 100% and 120% of the BEP capacity. These values are already given in the problem as 450, 600, 750 and 900 gal/min. Also, since the heads used in the Hydraulic

Institute charts must be based on per stage, we must divide the corresponding heads given above by 2 for the two stage pump.

Using the BEP value of head per stage (100 ft) along with the corresponding capacity (750 gal/min) we enter the Hydraulic Institute Viscosity Correction chart at 750 gal/min on the lower horizontal scale. Going vertically from 750 gal/min to the intersection point on the line representing the 100 ft head curve and then horizontally to intersect the 1000 SSU viscosity line. Finally vertically up to intersect the three correction factor curves C_e , C_q and C_h .

From the Hydraulic Institute chart (Figure 8) we obtain the values of correction factors C_q , C_h and C_e for flow rate, head and efficiency as follows:

C_q	0.95	0.95	0.95	0.95
C_h	0.96	0.94	0.92	0.89
C_e	0.635	0.635	0.635	0.635

Using the above correction factors, we calculate the Q, H and E values for the viscosity corrected curves by multiplying the water performance value by the respective correction factors. The following results are obtained for the viscous curve (per stage) with subscript v:

Q_v	427	570	712	855
H_v	109.5	101.5	92.0	76.5
E_v	46.0	50.8	52.1	50.5
BHP_v	23.1	25.9	28.6	29.4

The values for viscous BHP was calculated using Equation (4.1) as follows:

At $Q = 427$ $H = 109.5$ and $E = 46.0$

$$BHP_V = 427 \times 109.5 \times 0.9 / (3960 \times 0.46) = 23.1 \text{ per stage}$$

Since the correction factors were obtained based on heads per stage, the actual viscous performance curve, taking into account the 2 stages is as follows:

Q_V	427	570	712	855
H_V	219	203	184	153
E_V	46.0	50.8	52.1	50.5
BHP_V	46.2	51.8	57.2	58.8

Note that the Hydraulic Institute correction chart consists of two separate charts. One chart applies to small pumps up to 100 gal/min capacity and head per stage of 6 ft to 400 ft. The second (shown in Figure 8) is used for larger pumps with capacity ranging from 100 gal/min to 10,000 gal/min and head range of 15 ft to 600 ft per stage. Also, remember that when pump data is taken from a water performance curve, the heads must be per stage, since the Hydraulic Institute charts are based on head in ft per stage. Therefore, for a 4 stage pump with the BEP at 3000 gal/min and 1680 ft of head and an efficiency of 82%, the head per stage to be used with the Hydraulic Institute chart will be $1680/4 = 420$ ft. The total head from the water curve can then be multiplied by the correction factors to get the viscosity corrected head for the 4 stage pump.

Temperature rise of liquid due to pump inefficiency

Since the efficiency of a pump at any capacity is less than 100%, some of the energy of rotation of the pump impeller is converted to friction and subsequently causes heating of the pumped liquid. The amount of heating can be calculated using the following formula for the temperature rise of the liquid:

$$\Delta T = H (1/E - 1)/778C_p \quad (4.3)$$

Where ΔT is the temperature rise that occurs in the liquid at the operating point corresponding to the Head H and efficiency E . C_p represents the liquid specific heat in Btu/lb/F. The specific heat of a liquid is defined as the heat required to raise the temperature of a unit mass of liquid by one degree. It can be seen from the above equation that the temperature rise is zero when the pump efficiency is 100% ($E = 1.0$).

As an example, the temperature rise of a liquid in a pump operating at $H = 2000$ ft and $E = 80\%$, with a liquid specific heat of $C_p = 0.44$ is calculated as follows:

$$\Delta T = 2000 (1/0.8 - 1) / (778 \times 0.44) = 1.46 \text{ F}$$

5. Pump Drivers and Power Required

Centrifugal pumps may be driven by constant speed or variable speed drives. Most applications use constant speed electric motors to drive the pump at speeds such as 1800 RPM or 3600 RPM. The speed depends upon the synchronous speed of the electric motor, which in turn is a function of the electrical frequency (60 Hz in the USA) and the number of poles in the motor. The synchronous speed of an electric motor is calculated from the following equation:

$$N_s = 120xf/p \quad (5.1)$$

Where N_s is the synchronous speed (RPM) and f and p are the electrical frequency and the number of poles respectively.

For a 4-pole motor and 60 Hz frequency, the synchronous speed is

$$N_s = 120 \times 60 / 4 = 1800 \text{ RPM}$$

And for a 2-pole motor

$$N_s = 120 \times 60 / 2 = 3600 \text{ RPM}$$

With induction motors, there is a small difference between the synchronous speed and the actual motor speed, called the *slip*. Therefore, the motor speeds are reduced slightly and the pumps that are driven by these motors will run at 1780 RPM or 3560 RPM, depending upon the number of poles in the motor. Variable speed drives (VSD) include variable frequency drive (VFD) electric motors, gas turbine drives and engine drives. An alternate, less expensive, VSD using fluid coupling are used in some pipeline applications.

When a pump is driven by a constant speed electric motor the head capacity curve for a particular impeller diameter is as shown in Figure 9.

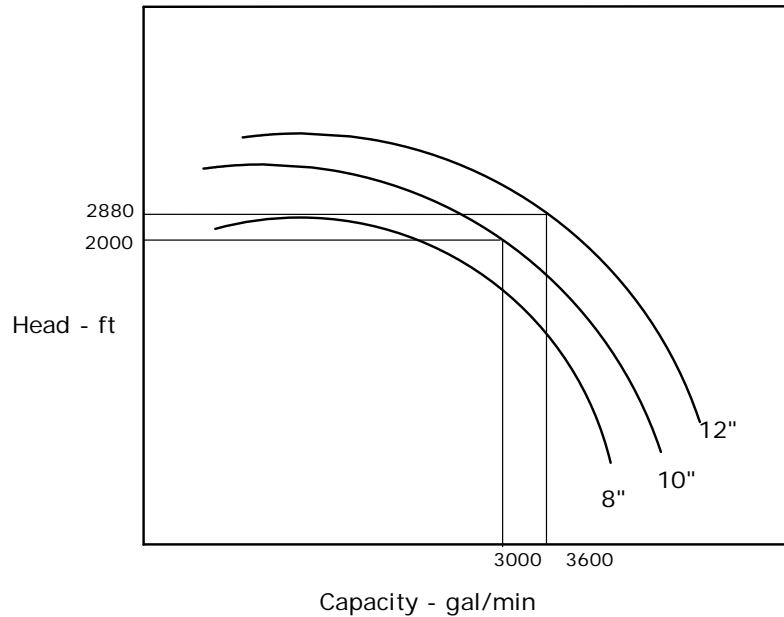

Figure 9 - Head - Capacity curves at Different Impeller Sizes

The H-Q performance of this pump can be changed by increasing or decreasing the impeller diameter, within some limits, depending on the pump design. This is illustrated in Figure 9 which shows the 10 inch impeller and the minimum and maximum impeller sizes (8 and 12 inch) possible with this pump.

The variation of the H-Q curve with impeller diameter and impeller speed, follow the Affinity Laws for centrifugal pumps, which will be discussed in more detail in Section 6. According to the Affinity Laws, the flow rate varies directly as the impeller diameter and the head varies as the square of the impeller diameter. In Figure 9, the operating point on the 10 inch impeller H-Q curve is 2000 ft at 3000 gal/min. If we increase the impeller diameter from 10 inch to 12 inch (ratio equals $12/10 = 1.2$) the

flow rate of the corresponding point on the 12 inch curve increases to $3000 \times 1.2 = 3600$ gal/min. and the corresponding head increases to $2000 \times (1.2)^2 = 2880$ ft. This is illustrated in Figure 9.

With variable speed pumps, the rated speed may be 3560 RPM and the minimum and maximum speeds may be 2000 RPM and 4000 RPM respectively. The H-Q curves for such a variable speed pump with a 10 inch impeller are shown in Figure 10.

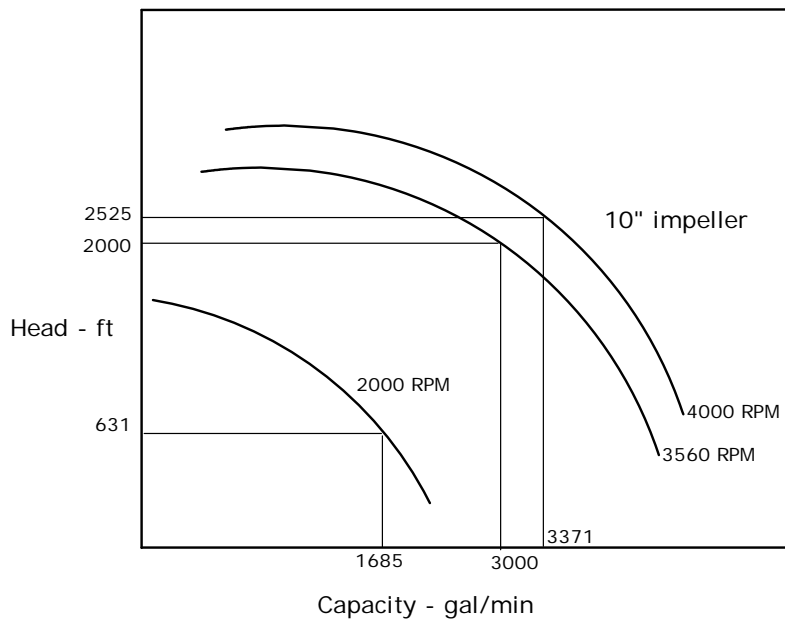

Figure 10 - Head - Capacity curves at Different Impeller Speeds

In Figure 10 we see that the same 10 inch diameter impeller when operated at the rated speed of 3560 RPM develops 2000 ft of head at 3000 gal/min. Upon increasing the speed to 4000 RPM the corresponding point on the new H-Q curve moves to 2525 ft at 3371 gal/min. Similarly, reducing the speed to 2000 RPM the operating point moves to 631 ft at 1685 gal/min. Thus with VSD pumps a fairly wide variation of H-Q curves can be generated at different speeds between minimum and maximum

speeds. The advantage of VSD pumps is that the pump speed may be lowered or raised to match the requirements of the pipeline system. This is discussed in more detail in the next section where pipeline system curves and pump curves are compared.

Power required

The power required to drive the pump is stated as hydraulic horsepower (HHP) or brake horsepower (BHP). The HHP is the theoretical horsepower required considering the pump efficiency as 100%. When the actual pump efficiency is taken into account, the pump horsepower is referred to as BHP. The equations used to calculate the two horsepower values are as follows:

$$\text{HHP} = Q \times H \times S_g / 3960 \quad (5.2)$$

$$\text{BHP} = Q \times H \times S_g / (3960E) \quad (5.3)$$

Where Q is the pump capacity in gal/min, H is the pump head in ft, E is the pump efficiency (decimal value, less than 1.0) and S_g is the liquid specific gravity.

In SI units, the power required is expressed in kW as follows:

$$\text{Power kW} = Q \times H \times S_g / (367.46E) \quad (5.4)$$

Where Q is the pump capacity in m³/hr, H is the pump head in meters, E is the pump efficiency (decimal value, less than 1.0) and S_g is the liquid specific gravity.

Sometimes the term water horsepower (WHP) is also used in connection with pump curves. This is simply the BHP required by a pump when the liquid pumped is water. Multiplying WHP by the liquid specific gravity we get the BHP when pumping a

specific liquid, as long as there is no viscosity correction involved. An example using various HP values discussed is presented next.

Example 5 (USCS units)

Consider a centrifugal pump with BEP as follows:

$Q = 2500$ gal/min, $H = 2000$ ft and $E = 80\%$.

Calculate the HHP and BHP at the BEP when pumping gasoline ($sg = 0.74$) using equations given above.

Solution

Using Equation (5.2) and (5.3) we get:

$$\text{HHP} = 2500 \times 2000 \times 0.74 / (3\ 960) = 934.34$$

$$\text{BHP} = 2500 \times 2000 \times 0.74 / (3\ 960 \times 0.80) = 1167.93$$

The WHP for this pump at the BEP will be calculated based on water instead of gasoline as follows, from equation (5.3)

$$\text{WHP} = 2500 \times 2000 \times 1.0 / (3\ 960 \times 0.80) = 1578.28$$

Example 6 (SI units)

Consider a centrifugal pump with BEP as follows:

$Q = 500$ m³/hr, $H = 600$ m and $E = 80\%$.

Calculate the power required in kW at the BEP when pumping crude oil (specific gravity = 0.85) using equations given above.

Solution

Using Equation (5.4) we get:

$$\text{Power} = 500 \times 600 \times 0.85 / (367.46 \times 0.8) = 867.44 \text{ kW}$$

In the above examples, the motor that drives the pump must have adequate HP to satisfy the pump BHP. In Example 5 the BHP required is approximately 1168 HP.

Therefore, the installed HP of the electric motor must be at least 10% above this.

$$\text{Installed motor HP} = 1.1 \times 1168 = 1285$$

Therefore, the closest commercially available electric motor of 1500 HP may be used. Remember that in the above example the pump BHP was calculated at the BEP. Since the capacity of the pump extends beyond the BEP, the BHP required at the highest capacity may be more than that calculated at the BEP. The installed motor HP must be large enough to satisfy the largest BHP requirement of the pump. To illustrate this, suppose the trailing point on the pump curve (maximum pump capacity) occurs at 4000 gal/min at a head of 1000 ft and 52% efficiency. The BHP required at the maximum capacity is

$$\text{BHP} = 4000 \times 1000 \times 0.74 / (3960 \times 0.52) = 1437.45$$

It can be seen that a 1500 HP motor will be marginal for this application. Considering a 10% cushion, the motor HP required is

$$\text{Installed motor HP} = 1.1 \times 1437.45 = 1581$$

Therefore, a 1600 or 1750 HP motor would be satisfactory.

In addition to pump efficiency, the motor efficiency must also be considered when determining the electric power requirements to run the pump. Compared to the pump efficiency, electric motor efficiency is quite high, in the range of 95% to 98%. Thus, in the above example considering 95% motor efficiency, the power requirement will be

$$\text{Power} = 1750 / 0.95 = 1842.11 \text{ kW, considering a 1750 HP motor.}$$

In most applications where an electric motor drives a centrifugal pump, the electric motor has a service factor ranging from 1.10 to 1.15. This means that in an emergency situation the electric motor is able to provide 10% to 15% more power than the name plate rating of the motor.

6. Affinity Laws and pump performance

In this section we will discuss the centrifugal pump Affinity Laws in more detail.

The H-Q performance curve of a centrifugal pump shown in Figure 11 depends upon the impeller diameter and impeller speed, as discussed earlier. This figure shows the head versus capacity curve of a centrifugal pump at constant speed, but at different impeller diameters, similar to Figure 9, discussed earlier.

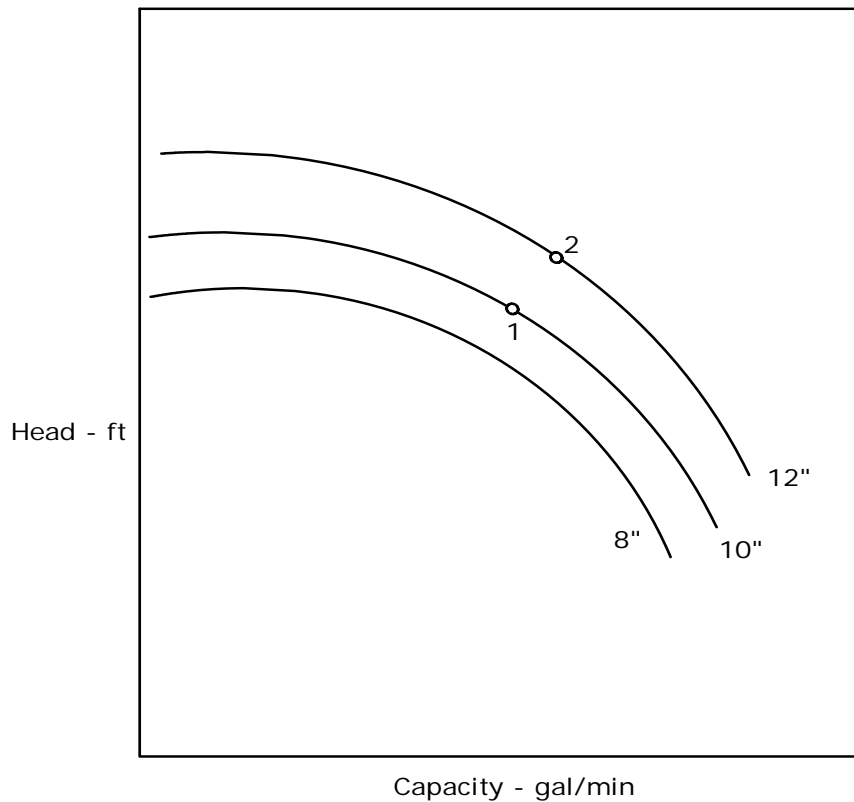

Figure 11 - Head versus Flow Rate - Different Impeller Sizes

If the impeller speed is kept constant and the impeller diameter increases from 10 inch to 12 inch, the new H-Q curve is located higher than that of the 10 inch curve. Similarly, reducing the impeller from 10 inch to 8 inch diameter will result in a lower H-Q curve as shown in Figure 11.

The variation of head versus capacity with impeller diameter is based upon the Affinity Laws. According to the Affinity Laws, the capacity increases with impeller diameter in a direct linear relationship. The pump head, on the other hand, increases as the square of the impeller diameter. The BHP or Power required, being proportional to the product of head and capacity (see Equation 5.2) increases as the cube of the impeller diameter. This is illustrated mathematically in the following equations.

For constant speed pump, with change in impeller diameter from D_1 to D_2 :

$$Q_2 / Q_1 = D_2 / D_1 \quad (6.1)$$

$$H_2 / H_1 = (D_2 / D_1)^2 \quad (6.2)$$

$$P_2 / P_1 = (D_2 / D_1)^3 \quad (6.3)$$

where Q_1, Q_2 are the initial and final capacities of a specific point on the pump curve for the two impeller diameter D_1, D_2 and H_1, H_2 are the initial and final heads and P_1, P_2 are the initial and final BHP corresponding to these points 1 and 2 in Figure 11. In the above example, $D_1 = 10$ inch and $D_2 = 12$ inch.

It must be noted that the Affinity Laws are only approximately correct for small changes in impeller diameter. A correction factor must be applied for large diameter changes. The pump vendor will be able to provide these correction factors.

The Affinity Laws may also be applied for predicting the performance of a pump with change in impeller speed. Keeping the impeller diameter constant, changing the pump speed from N_1 to N_2 results in the following changes in capacity and head, as illustrated in Figure 12.

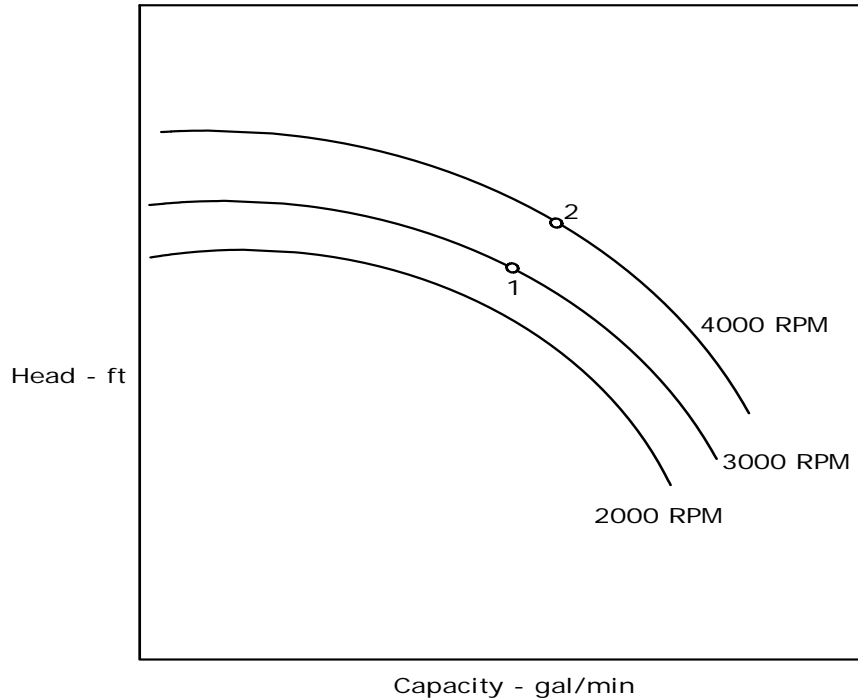

Figure 12 - Head versus Flow Rate - Different Impeller Speeds

For constant impeller size, for change in impeller speed from N_1 to N_2 :

$$Q_2 / Q_1 = N_2 / N_1 \quad (6.4)$$

$$H_2 / H_1 = (N_2 / N_1)^2 \quad (6.5)$$

$$P_2 / P_1 = (N_2 / N_1)^3 \quad (6.6)$$

Where Q_1, Q_2 are the initial and final capacities of a specific point on the pump curve for the two impeller speeds N_1, N_2 and H_1, H_2 are the initial and final heads and P_1, P_2 are the initial and final BHP corresponding to these points 1 and 2 as illustrated in Figure 11. In the above example, $N_1 = 3000$ RPM and $N_2 = 4000$ RPM.

It is seen from the above discussions, that we can generate a new set of H, Q values using the Affinity Laws, for change in impeller diameters or for change in impeller speeds. Remember, however, that while the Affinity Laws are only approximate for

impeller diameter changes, they are accurate for speed changes. With changes in impeller diameter and speed, the pump efficiency curve is assumed to remain the same. The next Example problem illustrates the application of Affinity Laws for pump impeller diameter change and speed change.

Example 7

The head and the efficiency versus capacity data for a centrifugal pump with a 10 inch impeller are as shown below.

Q - gal/min	0	880	1760	2640	3300
H - ft	3500	3410	3190	2580	1980
E - %	0.0	56.0	78.0	79.0	72.0

It is proposed to install a larger 12 inch diameter impeller. The pump driver is a constant speed electric motor that drives the pump at 3570 RPM.

- (a) Calculate using Affinity Laws, the revised H-Q performance with the new 12 inch impeller.
- (b) Keeping the original 10 inch impeller, the pump driver is changed to a variable speed drive (VSD) motor with minimum and maximum speeds of 2000 RPM and 4000 RPM respectively. Determine the new H-Q curve for the maximum speed of 4000 RPM.
- (c) What speed should the pump with the 10 inch impeller be run at to develop 3300 ft at 1800 gal/min?

Solution

(a) According to Affinity Laws, for impeller diameter changes, the H and Q values are multiplied by the following factors, when the impeller is changed from 10 inch to 12 inch.

$$\text{For flow rates, multiplier} = 12/10 = 1.2$$

$$\text{And for head, multiplier} = (1.2)^2 = 1.44$$

Using the above multipliers, a new set of Q and H values are calculated for the 12 inch impeller from the 10 inch impeller data as follows:

$$\text{Q - gal/min} \quad 0 \quad 1056 \quad 2112 \quad 3168 \quad 3960$$

$$\text{H - ft} \quad 5040 \quad 4910 \quad 4594 \quad 3715 \quad 2851$$

The efficiency versus flow rate curve will be the same as that of the 10 inch impeller.

(b) Using Affinity Laws for speeds, the speed increases from 3570 RPM to 4000 RPM.

The multiplier for the flow rate is

$$\text{multiplier} = 4000 / 3570 = 1.1204$$

$$\text{And the multiplier for head is } (1.1204)^2 = 1.2553$$

Based on the above multipliers, a new set of Q and H values are calculated at 4000 RPM as follows:

$$\text{Q - gal/min} \quad 0 \quad 986 \quad 1972 \quad 2958 \quad 3697$$

$$\text{H - ft} \quad 4394 \quad 4281 \quad 4004 \quad 3239 \quad 2485$$

The new efficiency versus flow rate curve at 4000 RPM will approximately be the same as that for the 3570 RPM curve.

(c) In order to determine the pump speed for the 10 inch impeller that develops 3300 ft head at 1800 gal/min, we must use a trial and error approach. An approximate value of the speed can be calculated using Affinity Laws as follows:

$$\text{Speed} = 3570 \times (3300/3190)^{1/2} = 3631 \text{ RPM}$$

Next, a new H-Q curve is created for 3631 RPM using Affinity Laws from the given H-Q data for the 10 inch impeller at 3570 RPM

Capacity multiplier for increasing speed from 3570 to 3631

$$= (3631/3570) = 1.0171$$

$$\text{Head multiplier} = (1.0171)^2 = 1.0345$$

The new H-Q curve data at 3631 RPM is as follows

Q - gal/min	0	895	1790	2685	3356
H - ft	3621	3528	3300	2669	2048

Examining the above data, we see that at 1800 gal/min, the head will be slightly less than 3300. Therefore, we must increase the speed slightly to match the Q = 1800, H = 3300 requirement.

Next try a speed ratio of 1.02

$$\text{New speed} = 3570 \times 1.02 = 3641 \text{ RPM}$$

Using the multiplier 1.02 for capacity, Q and $(1.02)^2 = 1.04$ for head H, the revised H-Q data at 3641 RPM is as follows:

Q - gal/min	0	898	1826	2693	3366
H - ft	3641	3548	3319	2684	2060

Examining the above data we see that at 1800 gal/min, the head will be slightly less than 3319 ft. The actual value can be determined by plotting the above data.

In the above analysis (Example 7, Part (a)), we explored the effect of increasing the pump impeller diameter to produce higher head with the pump speed remaining constant. In reality depending upon the pump size and pump model, the pump vendor will specify the minimum and maximum impeller diameters that can be accommodated in this pump. For example a pump model such as **6x8x11 DVMX** may accommodate a minimum impeller size of 8 inch and a maximum of 12 inch. Within this range of diameters the pump performance can be approximately predicted using Affinity Laws as we discussed in the example above. Therefore it is important that the pump vendor be contacted to determine the range of impeller diameters before predicting the pump performance for a specific diameter using Affinity Laws. Similarly, the range of pump speeds for a particular pump model may also be dictated by the vendor. Too high a speed will result in significant centrifugal force and consequent higher bearing pressures which might be detrimental to the pumps.

An example of the application of Affinity Laws for a centrifugal pump in a pipeline application will be discussed next. Assume that the pressure drop calculations for the pipeline show that a pump is required to provide a head of 2500 ft at a pipeline flow rate of 2000 gal/min. Reviewing the pump curve show in Figure 13 we see that the 10 inch impeller generates 2680 ft head at a flow rate of 2000 gal/min at an impeller speed of 3570 RPM.

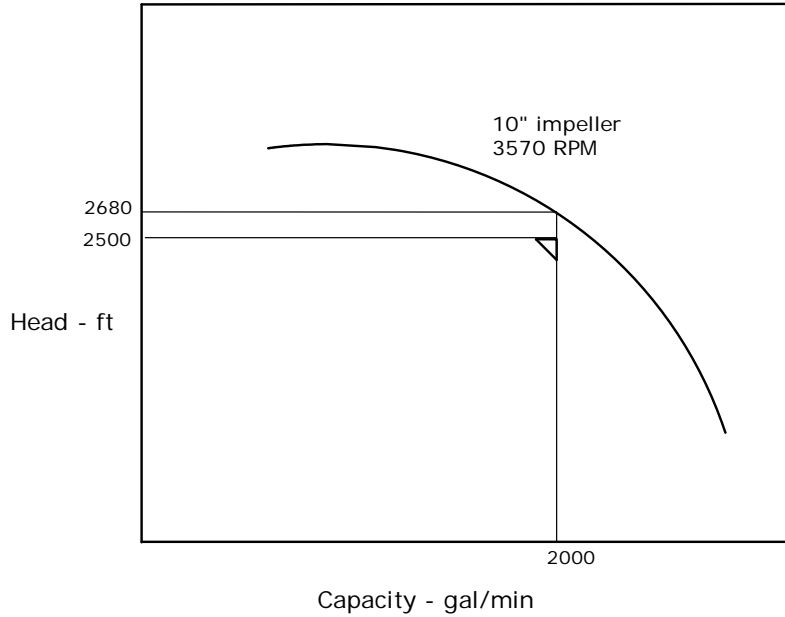

Figure 13 - Head - Capacity curve for 10" impeller

Obviously, this pump produces more head than that required for the pipeline application. We can reduce the impeller diameter slightly so that we achieve the required head of 2500 ft at 2000 gal/min. If the pump is driven by a constant speed electric motor we can trim the impeller and obtain the required head. On the other hand, if the pump driver is a VSD motor, the required head can be obtained by slowing the pump down from its rated speed of 3570 RPM to some lower speed that will generate the required head of 2500 ft. Therefore, we can solve this problem using the Affinity Laws. This will be explored more in the next section dealing with pipeline system head curves.

7. Pump Applications

In this section we will discuss the application of centrifugal pumps in series and parallel configuration, the pipeline system head curve and pump throttling. Sometimes, more than one pump is used in combination to provide the necessary pressure or flow rate for a particular application. The way pumps are configured depends upon the head and capacity required for the specific application.

Suppose a pipeline requirement is for the pump to provide 4000 gal/min flow rate at a pressure of 3000 ft of head. We may select a single pump that can provide this H-Q requirement. However, for operational flexibility we may decide to use two pumps in series such that each pump generates half the head required at the specified flow rate. Thus, each pump will be selected to provide 1500 ft head at 4000 gal/min capacity. The first pump will generate 1500 ft head which is then increased by another 1500 ft by the second pump to produce the total head of 3000 ft. Such a configuration, called series pumps, result in heads being additive for the same flow rate. In the above application, we could also have chosen two pumps in parallel configuration. In this case each pump will be selected to provide half the flow at the required head of 3000 ft. Thus each parallel pump will produce the same 3000 ft head at a capacity of 2000 gal/min. The flow rates in parallel pumps are additive. Schematically pumps in series and parallel are represented in Figure 14

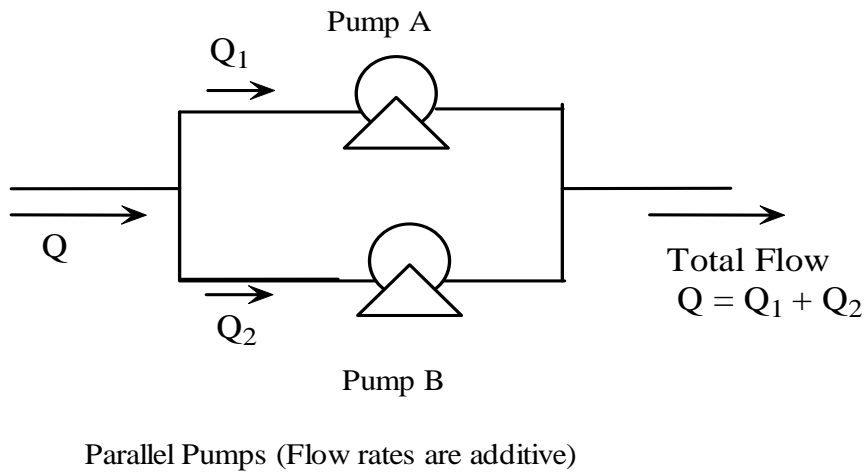
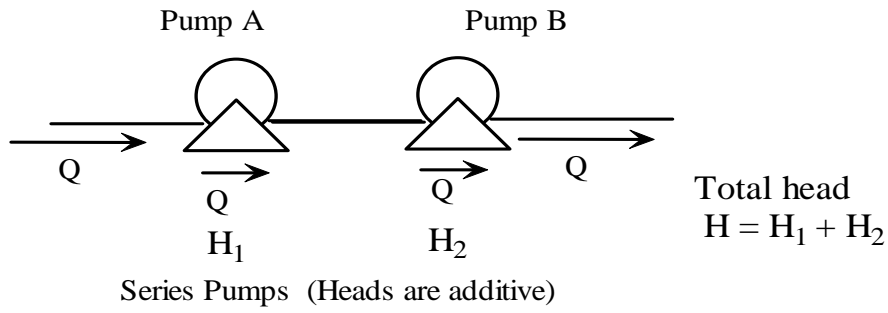

Figure 14 - Pumps in Series and Parallel

The next example illustrates how the combined performance of pumps in series and parallel are calculated from the individual pump performance data.

Example 8 (Series Pumps)

Two dissimilar pumps are configured to operate in series. Determine the combined pump performance. The water performance data of the pumps are as follows:

Pump A

Q - gal/min	0	400	800	1200	1500
H - ft	1195	1163	1088	882	675

Pump B

Q - gal/min	0	400	800	1200	1500
H - ft	1592	1550	1450	1176	900

Solution

Since the flow rate is common for series pumps and the heads are additive, the combined performance of the above two pumps are obtained by adding the heads of each pump for a particular flow and generating the following table:

The combined H-Q curve for Pump A and Pump B in series:

Q - gal/min	0	400	800	1200	1500
H - ft	2787	2713	2538	2058	1575

Example 9 (Parallel Pumps - SI units)

Two pumps are operated in a parallel configuration. Determine the combined pump performance. The water performance data of the pumps are as follows:

Pump A

Q – m ³ /hr	0	100	200	300	375
H - m	400	388	363	294	225

Pump B

Q – m ³ /hr	0	120	240	360	450
H - m	400	388	363	294	225

Solution

The common parameter for parallel pumps is the head. For each common head of each pump, the corresponding flow rates are additive. Therefore, the combined performance of the two pumps in parallel is obtained by adding the flow rates of each pump for a particular head. This generates the following table of Q-H values:

Combined H-Q curve for Pump A and Pump B in parallel:

Q – m ³ /hr	0	220	440	660	825
H - m	400	388	363	294	225

Note that for parallel pumps it is very important that there be a common head range for both pumps. Otherwise these pumps cannot operate in parallel. Similarly, for series pumps there must be a common flow range. This is illustrated in Figure 15 below. As far as possible, parallel pumps should be identical units, to operate effectively.

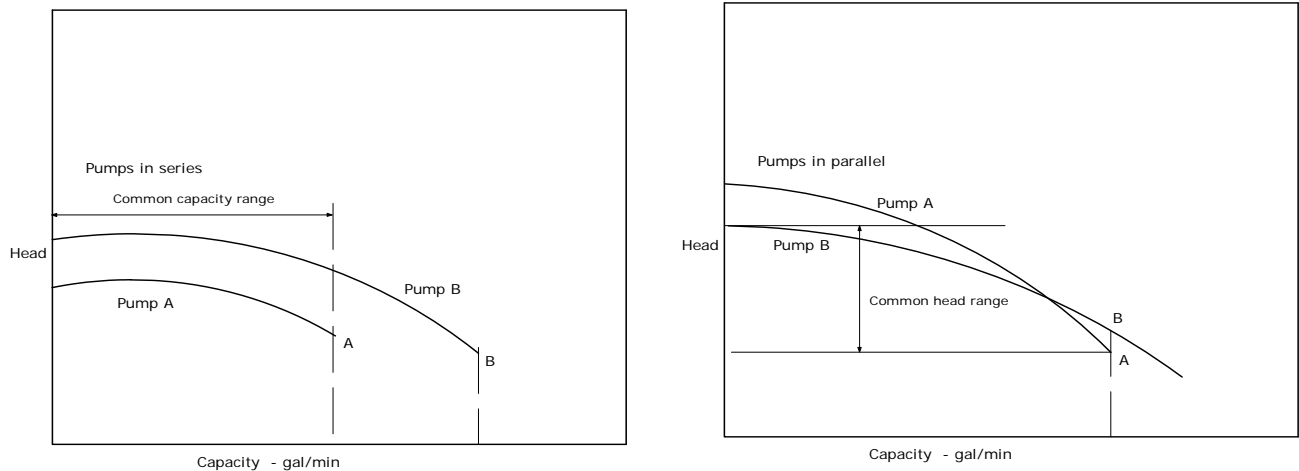

Figure 15 - Series and Parallel Pumps – Flow and Head Range

Note that in Example 8 there is a very narrow range of common heads (900 ft to 1195 ft) for the two pumps when operated in parallel. In contrast, in Example 9 there is a significant range of common flow rates (0 m³/hr to 375 m³/hr) for the two pumps when operated in series. Therefore any two pumps may not be both operated in series or parallel unless the above mentioned conditions are satisfied.

When identical pumps are operated in series or parallel, the combined efficiency curve will be the same as that of a single pump. However, when dissimilar pumps are operated in series, the combined efficiency curve cannot be determined easily. We know that the BHP of the combination is the sum of the individual BHP values. Also, with series pumps, flow rates

are additive. Therefore, the combined efficiency at any flow rate Q can be calculated from the following equation

$$(QH_1/E_1) + (QH_2/E_2) = Q(H_1 + H_2)/E \quad (7.1)$$

Where H_1 , E_1 and H_2 , E_2 are the head and efficiency of the two pumps at a capacity of Q and E is the efficiency of the combined pump curve.

Simplifying above equation and transposing we get the efficiency of the combined pump curve as follows

$$E = (H_1 + H_2) / (H_1/E_1 + H_2/E_2) \quad (7.2)$$

A similar analysis for identical pumps in parallel will result in the following efficiency of the combined pump curve

$$E = (Q_1 + Q_2) / (Q_1/E_1 + Q_2/E_2) \quad (7.3)$$

Where Q_1 and Q_2 are the capacities of the two pumps at a common head H .

Example 10 (Parallel Pumps)

In Example 8 with Pump A and Pump B operated in series what changes must be made such that the combined performance results in 2400 ft of head at 800 gal/min.

Solution

The combined pump curve produces 2538 ft head at 800 gal/min. Since we need only 2400 ft head, we need to reduce the head by $(2538 - 2400) = 138$ ft. We can trim the impeller on the larger Pump B such that it produces $(1450 - 138) = 1312$ ft head. We chose the larger pump since the percent trimmed will be less compared to the smaller Pump A, and hence the Affinity Laws are more accurate.

System Head Curve

The system head curve, also known as system curve, is a graphic representation of the pressure (or head) requirement at various flow rates in a pipeline transporting a liquid. Since a pump is used to supply pressure at a particular flow rate in a pipeline, we can use the system curve in conjunction with the pump head curve to determine the suitability of the pump.

Suppose a pump is located at the origin point A on a pipeline AB, 50 miles long, used to transport water from point A to point B. The system head curve for the pipeline is plotted at various flow rates as shown in Figure 16.

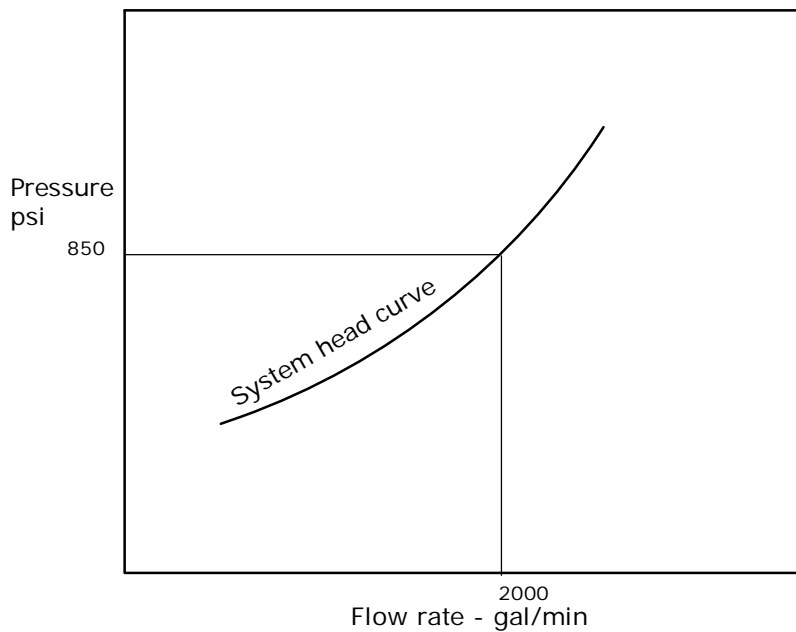

Figure 16 - System Head Curve

For each flow rate through the pipeline the pressure required at the origin A is calculated, considering pressure drop in the pipeline and accounting for any elevation difference along the pipeline from point A to point B. The reader is advised to check out the companion PDH Engineer online course, titled **Liquid Pipeline Hydraulics** for a more rigorous discussion of pressure drop calculations and pipeline hydraulics. An example of how a system head curve for a pipeline is generated will be discussed later in this section.

Since the pump H-Q curve is plotted in ft of head, the system head curve is also plotted in ft of head by converting the pressure in psi to ft of head using the Equation (2.8).

We can now superimpose the pump H-Q curve on the system head curve as shown in Figure 17.

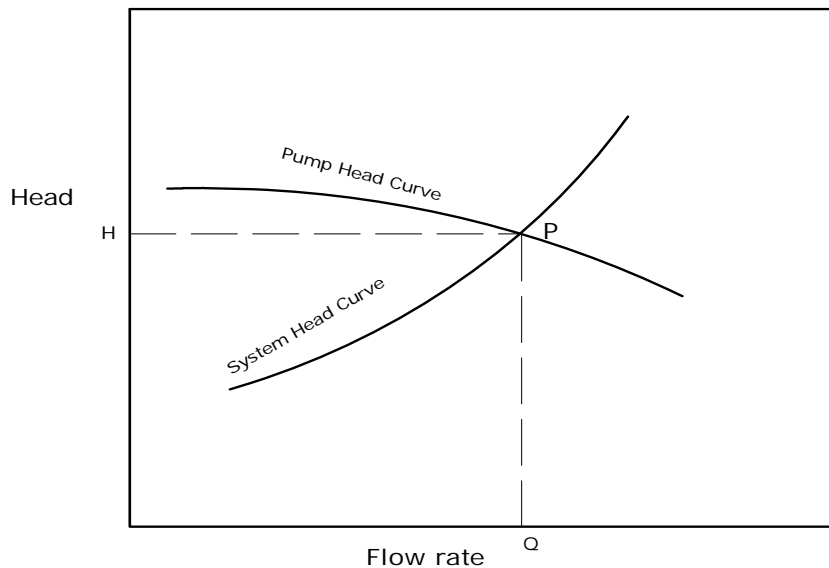

Figure 17 - System Head Curve and Pump Head Curve

The point of intersection P of the pipeline system head curve and the pump head curve in Figure 17 represents the operating point for this pump when used on this pipeline. This means that for a particular pump installed on a pipeline there is a single point of operation with respect to the system curve. The operating point P represents the flow rate Q at which the pipeline system head (H) required exactly matches the head (H) available from the pump. In order to increase the flow rate through this pipeline we must have a pump curve located above the current curve. This is depicted in Figure 18 where the upper dashed H-Q curve intersects the system head curve at a higher flow rate at Point T.

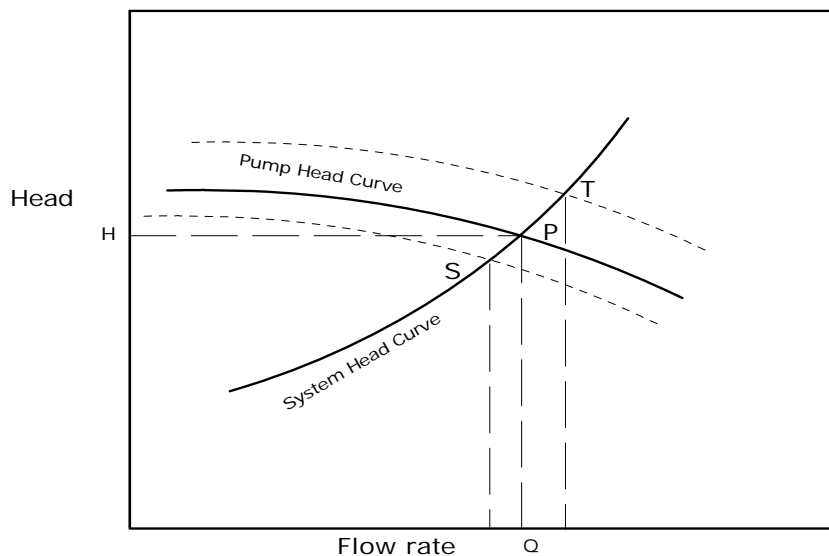

Figure 18 - System Head Curve and Various Pump Head Curves

Similarly, in order to operate at a lower flow rate, the pump H-Q curve must be located below the current curve as shown in the lower dashed curve in Figure 18. Point S represents the lower flow rate on the system curve corresponding to the lower H-Q curve for the pump. If the pump were driven by a variable speed motor we could speed up the H-Q curve from the solid curve to the dashed curve thereby

increasing the flow rate to that corresponding to point T. Conversely, by slowing the pump we can accomplish the lower flow rate corresponding to point S.

The exact point of operation of a pump depends on the system curve and the pump curve, as seen from above. If the system curve were flatter than shown in Figure 18, the point of operation P will be to the right of the present location, signifying a higher flow rate. Conversely, if the system head curve were steeper than shown above, the point of operation P will move to the left. This is illustrated in Figure 19, where different system curves are superimposed on the same pump head curve. It can be seen that a flatter system curve produces a higher flow rate at T, while a steeper system head curve will result in a lower flow rate at S.

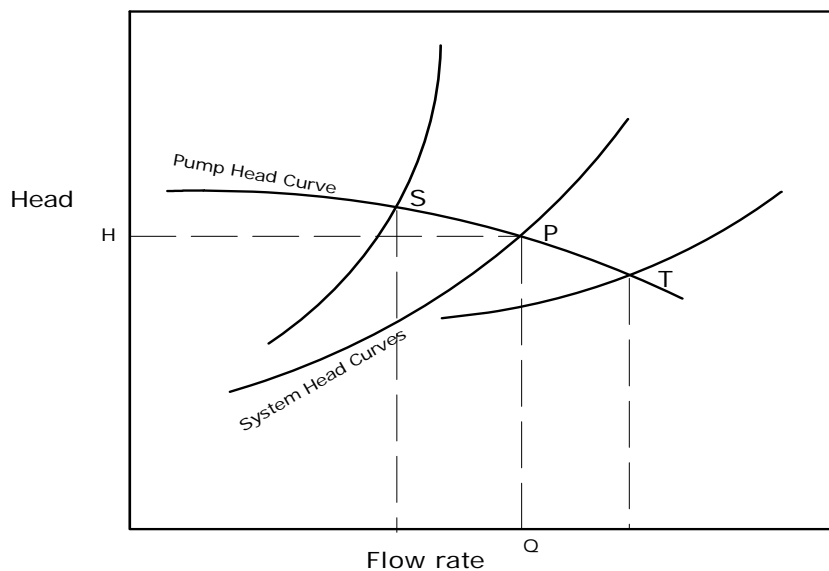

Figure 19 – Various System Head Curves and Pump Head Curve

The shape and steepness of the system head curve depends on various factors, including the pipe diameter, liquid specific gravity and viscosity, and the pipe elevation profile. Generally, higher viscosity and gravity of the liquid causes a

steeper system head curve, as will the smaller diameter pipeline. Larger pipe diameter and lower specific gravity and viscosity will result in flatter system head curves. An example will illustrate these concepts.

Developing a System Head Curve

As mentioned earlier, the development of a system head curve for a pipeline requires calculating the pressure drop at various flow rates and taking into account the elevation profile along the pipeline from point origin to the destination. In this section a brief introduction will be given to pressure drop calculations using the Darcy equation and the Colebrook - White equation for the friction factor. For a more rigorous analysis, the reader is advised to check out the companion PDH Engineer online course, titled **Liquid Pipeline Hydraulics**.

The pressure drop (head loss) in a pipeline is calculated from the Darcy Equation, as follows:

$$h = f (L/D) (V^2/2g) \quad (7.4)$$

Where h is the head loss due to friction in ft, L and D are the pipe length in ft and inside diameter of the pipe in ft respectively. The dimensionless term f is the friction factor and V is the average velocity of flow in ft/s. The constant g is the acceleration due to gravity and is equal to 32.2 ft/s² in USCS units.

A more convenient form of the Darcy equation that calculates the pressure drop P_m in psi/mi using flow rate Q in gal/min, pipe inside diameter D in inches and the liquid specific gravity S_g is as follows:

$$P_m = 71.118fQ^2(S_g/D^5) \quad (7.5)$$

The friction factor f depends on whether the flow is laminar or turbulent. Laminar flow occurs when the Reynolds number R is less than 2100. For R greater than 4000, the flow is considered to be turbulent. For the range of R between 2100 and 4000, the flow is considered to be undefined and called the critical region of flow.

The dimensionless parameter R is calculated from the flow rate, liquid viscosity and pipe inside diameter, as follows:

$$R = 3160Q/(vD) \quad (7.6)$$

Where Q is the flow rate in gal/min and v is the liquid viscosity in cSt and D is the inside diameter of the pipe.

Depending upon the value of R (for laminar or turbulent flow), the dimensionless friction factor is calculated from:

$$f = 64/R \quad \text{for Laminar flow } (R < 2100) \quad (7.7)$$

For turbulent flow ($R > 4000$), f is calculated using the Colebrook - White Equation:

$$1/\sqrt{f} = -2 \text{Log}_{10} [(e/3.7D) + 2.51/(R\sqrt{f})] \quad (7.8)$$

Where e is the absolute roughness of the interior of the pipe.

Finally, the total pressure required at the origin of the pipeline is calculated by adding the total pressure drop due to friction to the elevation difference between the ends of the pipeline and the final delivery pressure at the terminus.

$$P_t = P_m L + \Delta H \times S_g / 2.31 + P_{del} \quad (7.9)$$

Where L is the pipe length in miles, ΔH is the elevation difference in ft and P_{del} is the delivery pressure at the pipeline terminus. To develop the system head curve at various flow rates, the above calculations are repeated until enough pairs of data (P_t , Q) are available to plot a curve. Note that the P_t values will have to be converted to ft of head since the pump head curve is in ft of head.

A graphical method of calculating the value of f , for a given Reynolds number and pipe roughness is given in textbooks and the PDH Engineer online course **Liquid Pipeline Hydraulics**. This method uses the Moody Diagram, which is a graphic equivalent of the Colebrook - White Equation.

Example 11

A pipeline 50 miles long is used to transport gasoline (specific gravity = 0.735, viscosity = 0.8 cSt) from Beaumont refinery to a storage facility in Denton. The pipeline is 10.75 inch outside diameter and 0.250 inch wall thickness. The absolute roughness of the pipe interior is 0.002 inch. Two pumps with H-Q curves the same as Pump A and Pump B (Example 8) are configured in series at Beaumont. The suction pressure at Beaumont is 50 psi. What flow rate can be obtained through this pipeline, with a delivery pressure of 50 psi at Denton, and assuming the pipeline elevation profile is essentially flat?

Solution

We will use the Darcy equation to calculate the pressure drop in the pipeline, as a first step to generating the system head curve for the pipeline. For the flow rates, we will use a range that covers the capacity limit of the combined pump curves and slightly more.

1. First, calculate the Reynolds number R at each flow rate:

$$R = 3160Q/(\nu D)$$

2. Next we calculate the friction factor f :

For Laminar flow ($R < 2100$): $f = 64/R$

For turbulent flow ($R > 4000$) from the Colebrook - White Equation:

$$1/\sqrt{f} = -2 \text{Log}_{10} [(e/3.7D) + 2.51/(R \sqrt{f})]$$

3. Calculate the pressure drop per mile of pipe

$$P_m = 71.118fQ^2(S_g/D^5)$$

4. Calculate the total pressure required at Beaumont from

$$P_t = P_mL + P_{del}$$

The above calculations are repeated for each flow rate Q , to generate a set of P_t versus Q values which can then be plotted to obtain the system head curve. We will have to convert P_t to feet of head since the pump Head is in ft of head.

The sample calculations will be shown for a value of $Q = 1000$ gal/min:

$$\text{Inside diameter of pipe} = 10.75 - 2 \times 0.25 = 10.25 \text{ in}$$

$$R = 3160 \times 1000 / (0.8 \times 10.25) = 385,366$$

The flow is turbulent ($R > 4000$) and f is calculated from the Colebrook-White equation:

$$1/\sqrt{f} = -2 \log_{10} [0.002 / (3.7 \times 10.25) + 2.51 / (385,366 \sqrt{f})]$$

Solving by trial error, we get

$$f = 0.0158$$

The pressure drop per mile is

$$P_m = 71.118 \times 0.0158 \times (1000)^2 (0.735 / (10.25)^5) = 7.30 \text{ psi/mi}$$

The total pressure required at Beaumont is:

$P_t = 7.30 \times 50 + 50 = 415.0$ psi neglecting pipe elevations, since the pipeline profile is essentially flat.

The above calculations are repeated for flow rate from $Q = 0$ to $Q = 2000$ gal/min, in increments of 500, to generate a set of P_t versus Q for the system head curve, as follows. The head H_t is P_t converted from psi to ft of head:

$Q - \text{gal/min}$	0	500	1000	1500	2000
$P_t - \text{psi}$	50	149	415	840	1425
$H_t - \text{ft}$	157	468	1304	2640	4479

From Example 8, the combined H-Q curve for Pump A and Pump B in series is as follows:

$Q - \text{gal/min}$	0	400	800	1200	1500
$H - \text{ft}$	2787	2713	2538	2058	1575

Before we superimpose the pump curve with the system head curve we must add the static suction head of the pump. Since the suction pressure at Beaumont is 50 psi, converting to ft of head we get

$$50 \times 2.31 / 0.735 = 147 \text{ ft of gasoline}$$

We increase the above H values by 147 ft and plot the Q-H values on the same graph as the system head curve. The following is the result:

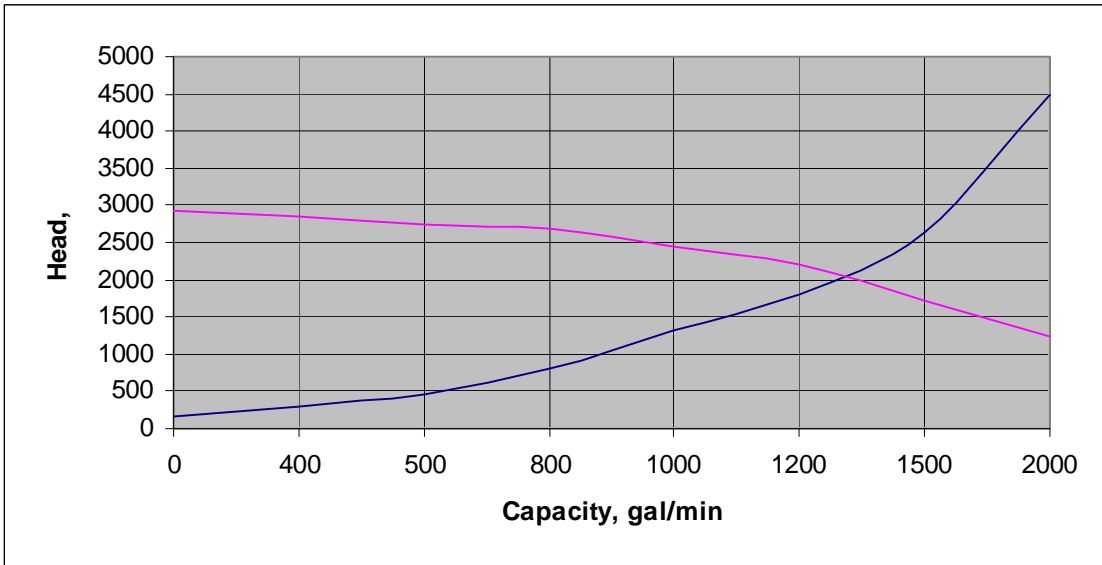

Figure 20 - System curve and pump head curve – Example 11

It can be seen from the intersection of the system curve and the combined pump curve in Figure 20, the operating point is at a flow rate of approximately 1300 gal/min.

Therefore, with the two pumps in series on the 50 mile pipeline, the gasoline flow rate out of Beaumont is 1300 gal/min.

Next we will examine the effect of combined pump curves in series and parallel and how they affect the operating point as the system head curve is superimposed on the pump curves.

When two or more pumps are used in series or parallel their effect on a system curve is displayed in Figure 21

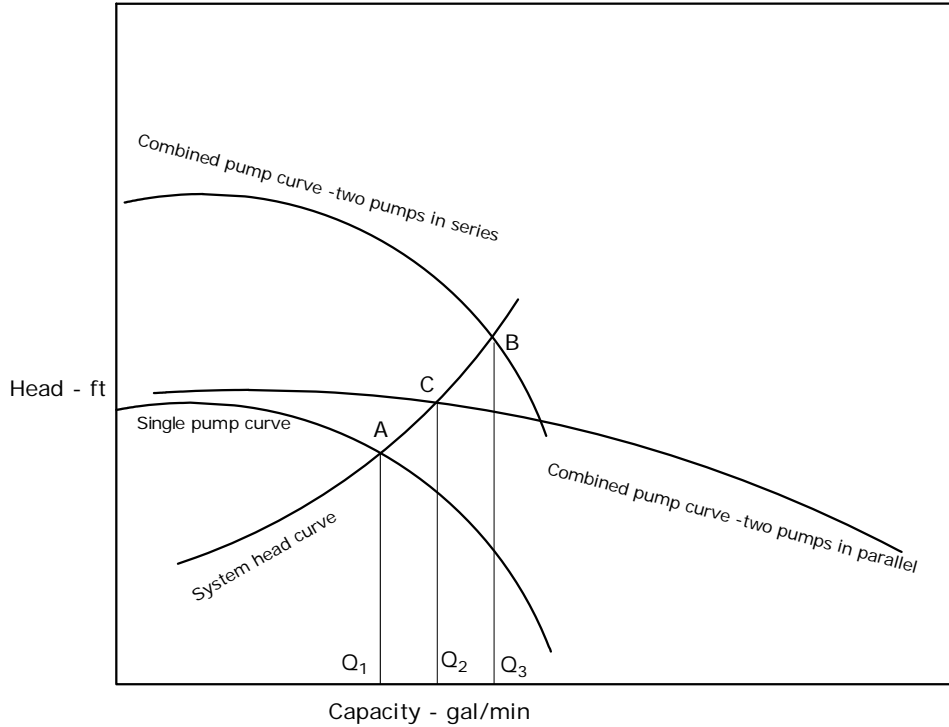

Figure 21 - Multiple Pumps with System Curve

Figure 21 shows a single pump head curve along with the combined pump head curves for two identical pumps in series and parallel configurations. The system head curve is also plotted for a pipeline, indicating the operating points depending upon the pump configuration.

With a single pump, the operating point is at point A. With two pumps in series the operating point moves to point B. In parallel configuration, the operating point moves to the point C. The corresponding flow rates are shown as Q_1 for single pump, Q_3 for series pumps and Q_2 for parallel pumps.

In the preceding discussions, we plotted the pump H-Q curve along with the pipeline system head curve to determine the operating point. In all cases we used feet of head of liquid for the system curve and pump curve. If we plotted the system head

curve with the head pressure in psi, instead, we will also have to plot the pump head curve in psi. The conversion between head in ft of liquid and pressure in psi is quite simple as shown in Equation (2.8).

Batching Petroleum Products

When two different liquids, such as diesel and gasoline, are pumped in a pipeline in a batched mode, it will be instructive to see how the pump head curve and system curves are displayed, taking into account the specific gravity of the two liquids. When all pressures are expressed in psi, instead of feet of liquid head, Figure 22 shows the system curves for diesel and gasoline along with the pump head curves.

When the pump contains gasoline, the pressure developed by the pump in psi depends upon the specific gravity of gasoline and is shown as the lower pump head curve. Similarly, for the heavier diesel in the pump the head curve is shown as the upper pump head curve. Since we are plotting pressures in psi and not in ft of liquid head we end up with two separate pump head curves for the two products. The points A, B, C and D represent the points of intersection between the two system head curves and the two pump head curves. When gasoline fills the pump and the pipeline, the operating point is at D corresponding to a pipeline flow rate of Q_D . Similarly, when diesel fills the pump and the pipeline, the operating point is at C which corresponds to a pipeline flow rate of Q_C . Consider now that the entire pipeline is filled with a batch of diesel and the pump is full of gasoline. This results in an operating point B that corresponds to a flow rate of Q_B . Finally when gasoline fills the pipeline and diesel fills the pump the operating point is at A resulting in pipeline

flow rate of Q_A . It can thus be seen from Figure 22 that the pipeline flow rate when batching gasoline and diesel ranges from a low of Q_B to a high of Q_A gal/min.

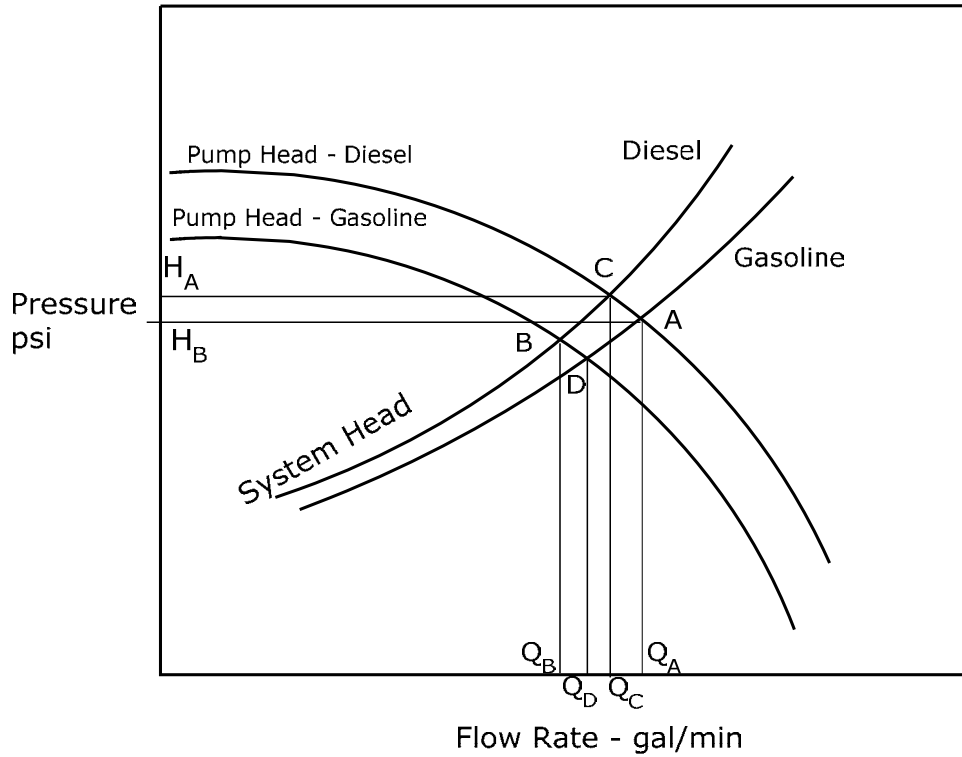

Figure 22 – System Curve - batching two products

When selecting pumps for such a batched pipeline application, care must be taken to ensure that the pump drive motor is adequately sized, since the BHP required depends on the liquid specific gravity. Similarly, when selecting the pump, the highest head required would usually be when the heavier product fills the pipeline and the lighter product fills the pump.

$$\text{Throttle pressure} = (1650 - 1400) \times 1.0 / 2.31 = 108.23 \text{ psi}$$

assuming water as the liquid pumped.

The throttling is accomplished by a control valve located at the discharge of the pump. In reality, due to the control valve, the system head curve is modified as shown by the upper curve (2), resulting in the revised system head curve passing through the point B on the pump H-Q curve.

Although it is possible to operate the above system at the reduced flow rate, using a control valve to throttle the pump pressure, this is not efficient. The throttle pressure represents wasted pump head and therefore wasted energy. The energy lost in throttling can be calculated as follows:

$$\text{Energy lost in throttling} = (\text{throttle pressure (ft)} \times Q \times S_g) / (3960 \times \text{Eff}_y)$$

Assuming the pump efficiency at a flow rate of 1800 gal/min is 80% and considering water as the liquid pumped,

$$\text{Energy lost} = (1650-1400) \times 1800 \times 1.0 / (3960 \times 0.8) = 142.05 \text{ HP}$$

Assuming an electrical energy cost of 10 cents per kWh this represents a loss of

$$142.05 \times 0.746 \times 24 \times 365 \times 0.1 = \$92,829 \text{ per year}$$

Clearly we must avoid such wasted energy. The solution would be to trim the pump impeller or use a VSD pump to reduce speed.

In a typical pump installation, there are certain pressure terms that must be clarified. The pump suction pressure is the pressure of the liquid at the suction of the pump. This will be equal to the difference between the liquid head in the tank and the pressure loss in the suction piping between the tank and the pump suction. The discharge pressure of the pump equals the suction pressure plus the head developed by the pump. If a control valve is located on the discharge side of the pump the pressure upstream of the control valve is called the pump case pressure. The pressure downstream of the control valve is known as the pipeline discharge pressure. These terms are illustrated in Figure 24. The pump throttle pressure is the difference between the case pressure and the discharge pressure.

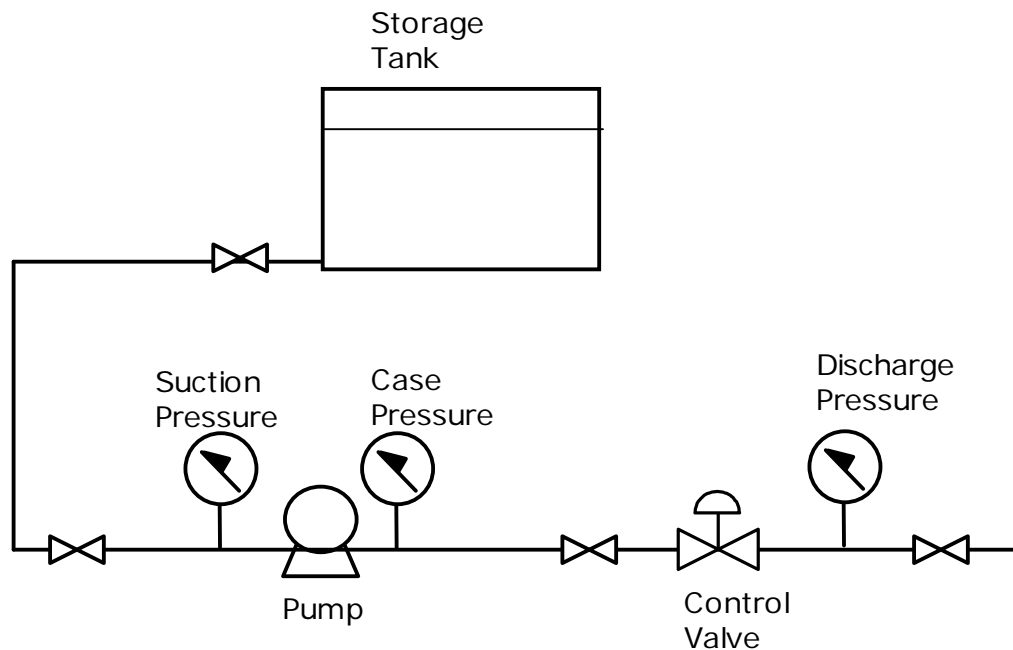

Figure 24 - Single Pump Schematic

Net Positive Suction Head (NPSH)

Earlier, we briefly discussed the NPSH required for a centrifugal pump. As the flow rate through the pump increases, the NPSH requirement also increases. If inadequate suction pressure exists at the pump suction, pump cavitation may occur, resulting in damage to the pump impeller. It is therefore important to calculate the available NPSH based upon the actual piping configuration for a particular pump installation. The calculated NPSH represents the available NPSH and hence must be greater than or equal to the minimum NPSH required for the pump at a particular flow rate. We will illustrate this using an example

Example 12

The bottom of a storage tank containing a liquid (specific gravity = 0.85, viscosity = 2.5 cSt) is located at an elevation of 20 ft above the centerline of the pump as shown in Figure 25. The head of liquid in the tank is 30 ft.

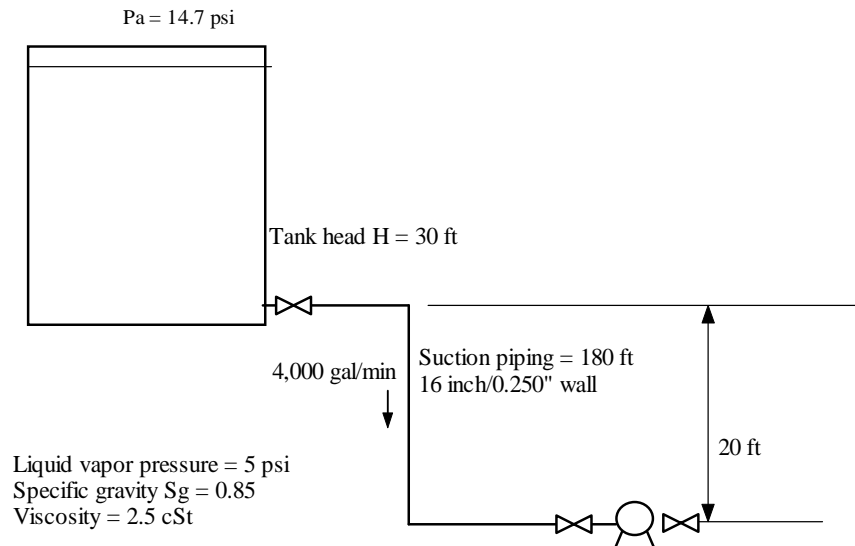

Figure 25 - NPSH Available

The total equivalent length of 16 inch, 0.250 inch wall thickness pipe (including pipe, fittings etc.) between the tank and the pump is 180 ft. The liquid level in the tank is 30 ft and the vapor pressure of the liquid at pumping temperature of 70 F is 5 psia. Considering an atmospheric pressure of 14.7 psia, calculate the NPSH available for the pump at a flow rate of 4,000 gal/min.

Solution

The pressure drop in the 180 ft equivalent length of 16 inch pipe at 4,000 gal/min is calculated first.

$$\begin{aligned} \text{Reynolds number } R &= 3160 \times 4000 / (2.5 \times 15.5) \\ &= 326,194 \end{aligned}$$

$$\text{Assuming } e/D = 0.002/15.5 = 0.000129$$

Friction factor f is calculated using Colebrook-White equation as follows

$$1/\sqrt{f} = -2 \text{Log}_{10} [0.000129/3.7 + 2.51/(326194 \sqrt{f})]$$

Solving for f by trial and error

$$f = 0.0155$$

Therefore, the pressure drop is

$$\begin{aligned} P_m &= 71.118 \times 0.0155 (4000)^2 \times (0.85/(15.5)^5) \\ &= 16.76 \text{ psi/mi} \end{aligned}$$

Total frictional pressure drop in 180 ft of 16 inch pipe is

$$\Delta P_f = 16.76 \times (180/5280) = 0.57 \text{ psi}$$

The NPSH available at pump suction is

$$\begin{aligned} \text{NPSH}_A &= 14.7 \text{ psia} + (30+20) \text{ ft} - 5 \text{ psia} - 0.57 \text{ psig} \\ &= (14.7 - 5 - 0.57) \times 2.31/0.85 + 50, \text{ all in feet of liquid head} \\ &= 24.8 + 50 = 74.8 \text{ ft} \end{aligned}$$

If the tank level drops to one ft, the NPSH will drop to $74.8 - 29 = 45.8 \text{ ft}$

Note that when calculating NPSH available, the pressures must be in absolute units (psia instead of psig). Hence, the atmospheric pressure is added to obtain psia as in above calculation.

It is important to ensure that in any piping installation, the NPSH available, as calculated above is more than the minimum NPSH required by the pump at any flow rate. Otherwise, the pump will cavitate and cause damage to the impeller.

References

1. Liquid Pipeline Hydraulics, E. Shashi Menon, Marcel Dekker, Inc. 2005
2. Piping Calculations Manual, E. Shashi Menon, McGraw – Hill, 2005
3. Cameron Hydraulic Data. Ingersoll-Rand, 1981
4. Centrifugal Pumps Design & Application, V.S. Lobanoff and R.R. Ross, Gulf Publishing, 1985
5. Hydraulic Institute Engineering Data Book - Hydraulic Institute, 1979