



# ***PDHengineer.com***

**Course No S-6001**

## **Stress and Failure Analysis of Laminated Composite Structures**



This document is the course text. You may review this material at your leisure before or after you purchase the course. If you have not already purchased the course, you may do so now by returning to the course overview page located at:

<http://www.pdengineer.com/pages/S-6001.htm>

(Please be sure to capitalize and use dash as shown above.)

Once the course has been purchased, you can easily return to the course overview, course document and quiz from PDHengineer's My Account menu.



If you have any questions or concerns, remember you can contact us by using the Live Support Chat link located on any of our web pages, by email at [administrator@PDHengineer.com](mailto:administrator@PDHengineer.com) or by telephone toll-free at 1-877-PDHengineer.

Thank you for choosing PDHengineer.com.

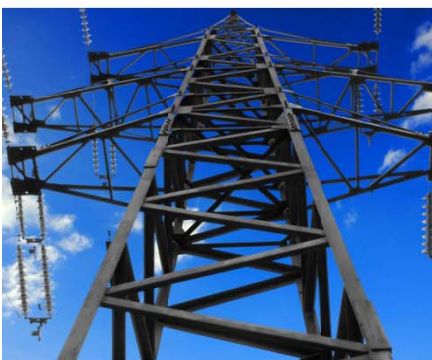

5870 HIGHWAY 6 NORTH | SUITE 110 | HOUSTON, TX | 77084

**STRESS AND FAILURE ANALYSIS OF  
LAMINATED COMPOSITE STRUCTURES**

**(Emphasis on Classical Lamination Theory)**

**John J. Engblom, Ph.D., P.E.  
Professor Emeritus  
Florida Institute of Technology**

## TABLE OF CONTENTS

1.0	Introduction	4
2.0	Material Definitions	5
2.1	Isotropic Material Behavior	5
2.2	Anisotropic Material Behavior	5
2.3	Orthotropic Material Behavior	6
3.0	Hooke's Law for Orthotropic Materials	6
4.0	Restrictions on Elastic Constants	14
5.0	Stress-Strain Relations for Generally Orthotropic Lamina	16
6.0	Biaxial Strength Theories for Orthotropic Lamina	23
6.1	Separable Strength (Failure) Theories	25
6.1.1	Maximum Stress Theory	25
6.1.2	Maximum Strain Theory	28
6.1.3	Hashin Quadratic Theory	30
6.1.4	Chang Quadratic Theory	34
6.2	Generalized Strength (Failure) Theories	37
6.2.1	Tsai-Hill Theory	37
6.2.2	Tsai-Wu Tensor Theory	41
6.3	Another Example Comparing Failure Theories	47
6.4	Failure Envelopes (Generalized Theories) for Biaxial Stress State	49
6.5	Effect of Shear Stress Direction on Lamina Strength	54
7.0	Analysis of Laminated (Multi-Layered) Composites	55
7.1	Specifying Stress and Strain Variation in a Laminate	55
7.2	Relating Resultant Forces and Moments to Strain and Curvature	59

7.3	Including Hygrothermal Effects in Laminate Analysis	63
7.4	Construction and Properties of Various Laminates	69
7.4.1	Symmetric Laminates	70
7.4.2	Unidirectional, Cross-Ply and Angle-Ply Laminates	70
7.4.3	Quasiisotropic Laminates	72
7.5	Some Examples of Laminate Analysis	73
7.5.1	Two-Ply [45/0] Laminate Subjected to Applied Loads	74
7.5.2	Two-Ply [45/0] Laminate Subjected to Thermal Load Only	78
7.5.3	Two-Ply [45/0] Laminate Subjected to Applied and Thermal Loads	82
7.5.4	Quasiisotropic [0/45/-45/90] <sub>s</sub> Laminate Subjected to Applied Loads	84
8.0	Summary	87
9.0	References	87

## 1.0 INTRODUCTION

This course focuses on presenting a well established computational method for calculating stresses/strains in reinforced laminated composite structures. The basis for the presented computational method is often referred to as *classical lamination theory*. A clear understanding of this approach is supported by the development of the fundamental mechanics of an orthotropic lamina (ply). Various failure theories are presented each requiring that stresses/strains be quantified on a ply-by-ply basis in order to make failure predictions. Both applied loads and hygrothermal (thermal and moisture) effects are treated in the computational procedure. Stress and failure predictions are an important part of the process required in the design of laminated composite structures.

The *learning objectives* for this course are as follows:

1. Understanding the differences between isotropic, orthotropic and anisotropic material behavior
2. Having knowledge of the material constants required to define Hooke's law for an orthotropic lamina (ply)
3. Understanding the restrictions on the material constants required in evaluating experimental data
4. Knowing the difference between reference and natural (material) coordinates for an orthotropic lamina
5. Being familiar with the stress-strain relations in reference and natural coordinates for an orthotropic lamina
6. Understanding the coordinate transformations used in transforming stresses and/or strains from one coordinate system to another
7. Knowing generally the types of tests performed to determine the stiffness and strength properties of an orthotropic lamina
8. Having knowledge of a number of biaxial strength (failure) theories used in the design of laminated composite structures
9. Understanding which in-plane strength quantities are needed, as a minimum, in applying various failure theories
10. Knowing the difference between separable and generalized failure theories
11. Understanding that the maximum stress and maximum strain failure theories make similar predictions except under certain material behavior
12. Appreciating under what conditions the Chang failure criteria reduces to the Hashin failure criteria
13. Knowing the basis for the fact that the Tsai-Wu failure criteria is more general than the Tsai-Hill failure criteria
14. Being familiar with the effect of the direction of shear stress on lamina strength
15. Understanding the laminate orientation code used to define stacking sequence
16. Being familiar with a number of special laminate constructions designed to eliminate undesirable composite material behavior
17. Understanding the computational procedure for determining the stresses/strains in a laminated composite subject to applied loads and/or hygrothermal effects
18. Having knowledge of the limitations of classical lamination theory.

It is important to note a limitation on the computational methodology presented in this course. Stress predictions from *classical lamination theory* are quite accurate in locations away from boundaries, e.g., free edges, edge of a hole or cutout, etc., of the laminate. Thus at distances equal to the laminate plate(shell) thickness or greater, the computational method presented herein is accurate and useful in the preliminary design of laminated composite structures. The basis for this limitation is that lamination theory assumes a generalized state of plane stress which is reasonably accurate away from boundaries. Along boundaries, the state of stress becomes three-dimensional with the possibility that interlaminar shear and/or interlaminar normal stresses can become significant. Deviation of lamination theory along laminate boundaries is often referred to as a *boundary-layer phenomenon*. Computation of stresses along laminate boundaries is generally accomplished through the application of finite difference, finite element or boundary element method computer programs and is beyond the scope of the methodology presented in this course.

## 2.0 MATERIAL DEFINITIONS

A *lamina* or *ply* can be thought of as a single layer within a composite laminate and is comprised of a matrix material and reinforcing fibers. When the fibers are long the layer is referred to as a continuous-fiber-reinforced composite and the matrix serves primarily to bind the fibers together. Alternatively layers with short fibers are denoted as discontinuous-fiber-reinforced composites. Lamina are quite thin, i.e., generally on the order of 1 mm or .005 in. thick. Lamina can have unidirectional or multi-directional fiber reinforcement. Therefore a number of lamina bonded together form a *laminate*. Most laminated composites used in structural applications are in fact multilayered. Laminates have identical constituent materials in each ply; otherwise the term *hybrid* laminate is used for laminates comprised of plies with different constituent materials. Fiber reinforced composites are heterogeneous but for purposes of design analysis are typically assumed to be macroscopically homogeneous. Thus for the computational methodology presented in this course, orthotropic lamina (plies) are treated as homogenous with directionally dependent properties. Orthotropic material behavior falls somewhere between that of isotropic and anisotropic materials.

### 2.1 Isotropic Material Behavior

For isotropic materials deformation behavior is independent of direction. Thus normal stresses produce normal strains only and shear stresses produce shear strains only, as depicted in the figure below.

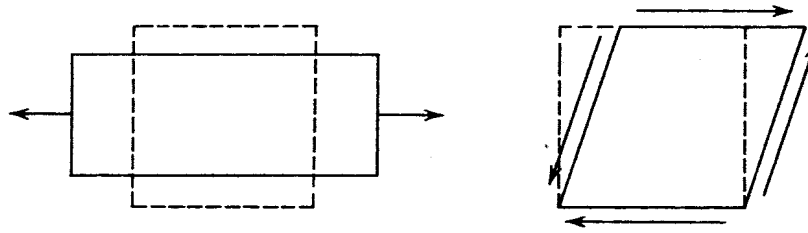

**Figure 2.1. Extensional and Shear Deformation, Isotropic Material**

## 2.2 Anisotropic Material Behavior

In the case of anisotropic materials, deformation behavior is dependent on direction. Thus, uniaxial tension produces both extensional and shear components of deformation. Likewise, pure shear loads also produce extensional and shear deformation. Anisotropic material behavior is depicted in the simple sketch below.

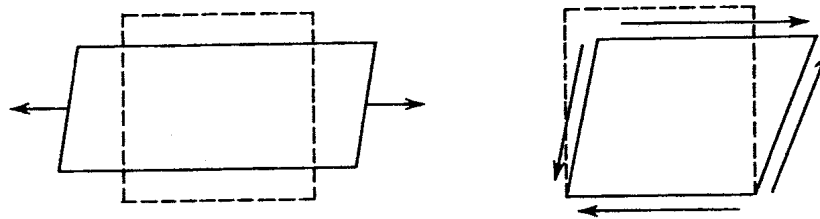

**Figure 2.2. Extensional and Shear Deformation, Anisotropic Material**

## 2.3 Orthotropic Material Behavior

In the case of orthotropic materials deformation is, in general, direction dependent. An exception occurs when loads are applied in natural (material) coordinates. These are by definition coordinates in the plane of the lamina, wherein *the longitudinal coordinate is aligned with the fiber reinforcement and the transverse coordinate is aligned normal to the fiber reinforcement*. Longitudinal and transverse directions are material axes of symmetry in a unidirectionally reinforced composite. When loads are applied in these natural coordinates the material response is similar to that of isotropic materials, i.e., normal stresses produce normal strains only and shear stresses produce shear strains only as shown below.

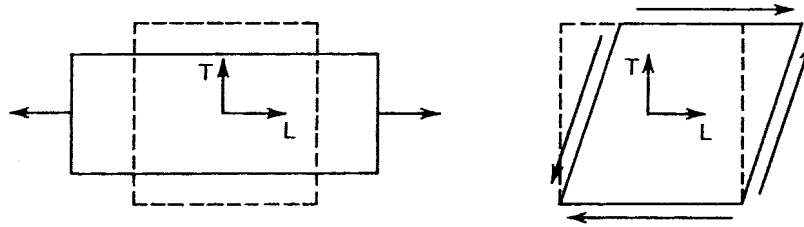

**Figure 2.3. Extensional and Shear Deformation, Orthotropic Material, (Loaded Along Material Coordinates)**

Here the longitudinal and transverse axes are labeled as L and T, respectively. Unidirectionally reinforced composites are often referred to as specially orthotropic. Furthermore, unidirectionally reinforced laminas are isotropic in the out-of-plane (normal to the plane of the lamina) direction.

### 3.0 HOOKE'S LAW FOR ORTHOTROPIC MATERIALS

Generalized Hooke's law has the tensorial form

$$\sigma_{ij} = E_{ijkl} \varepsilon_{kl} \quad (3.1)$$

where stresses are related to strains through the elastic constants  $E_{ijkl}$ . In the matrix form of the constitutive equations, we have

$$\begin{matrix} \{\sigma\} = [E]\{\varepsilon\} \\ 9 \times 1 \quad 9 \times 9 \quad 9 \times 1 \end{matrix} \quad (3.2)$$

Here, the stress and strain tensors are of order  $9 \times 1$  and there are  $9 \times 9$  or a total of 81 elastic constants in the stiffness matrix  $[E]$ . It will be shown that these 81 elastic constants reduce to 21 constants even without any axes of symmetry. With 21 independent elastic constants we have an anisotropic material. The stress tensor notation is sketched in figure 3.1 below.

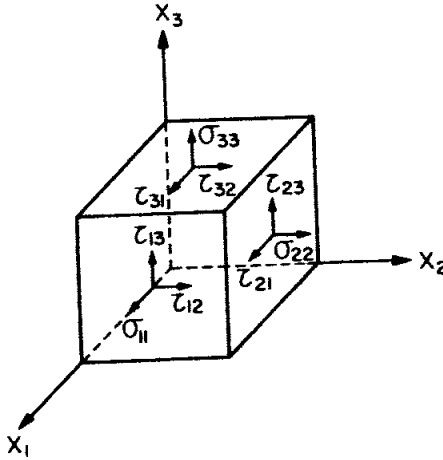

**Figure 3.1. Stress Tensor Notation**

Consider going through this reduction in the number of elastic constants. First, consider that we have symmetry in the strains, i.e.,

$$\varepsilon_{ij} = \varepsilon_{ji} \quad j \neq i$$

It is therefore easily shown that

$$E_{ijkl} = E_{ijlk}$$

We also have symmetry in the stress tensor, i.e.,  $\sigma_{ij} = \sigma_{ji}$  and therefore,

$$E_{ijkl} = E_{jikl}$$

And thus the two symmetries reduce the elastic constants from 81 to 36. We have

$$\begin{matrix} \{\sigma\} \\ 6 \times 1 \end{matrix} = \begin{matrix} [E] \\ 6 \times 6 \end{matrix} \begin{matrix} \{\varepsilon\} \\ 6 \times 1 \end{matrix} \quad (3.3)$$

Here we have a total of 36 elastic constants.

Now consider the strain-energy density function defined as a function of the strains as

$$U = U(\varepsilon_{ij}) \quad (3.4)$$

with the property

$$\partial U / \partial \varepsilon_{ij} = \sigma_{ij} \quad (3.5)$$

The simple 1-D analogy of (3.5) relates to the fact that the area under the stress-strain curve is equal to the strain energy density. In the 1-D case we have

$$U = \frac{1}{2} \sigma \epsilon$$

Substituting the 1-D form of Hooke's law, i.e.,  $\sigma = E\epsilon$  into the above gives

$$U = \frac{1}{2} E \epsilon^2$$

Thus we have simply

$$\partial U / \partial \epsilon = E \epsilon = \sigma$$

for a simple uniaxial state of stress.

Getting back to the 3-D case, we substitute the stress-strain relations (3.1) into (3.5)

$$\partial U / \epsilon_{ij} = E_{ijkl} \epsilon_{kl} \quad (3.6)$$

Taking the derivative again we have

$$\partial / \epsilon_{kl} (\partial U / \partial \epsilon_{ij}) = E_{ijkl} \quad (3.7)$$

Interchanging indices gives

$$\partial / \epsilon_{ij} (\partial U / \epsilon_{kl}) = E_{klij} \quad (3.8)$$

Since the order of differentiation is immaterial we have

$$\partial / \epsilon_{ij} (\partial U / \epsilon_{kl}) = \partial / \epsilon_{kl} (\partial U / \epsilon_{ij})$$

Therefore

$$E_{ijkl} = E_{klij}$$

Since ij and kl are interchangeable, we now have 21 constants for an anisotropic material.

In the matrix form of the previously written constitutive equations (3.3), the stiffness matrix  $[E]$  is therefore a symmetric matrix. We have  $n(n+1)/2$  independent constitutive terms in  $[E]$ , where  $n=6$ .

It is more convenient to write Hooke's law in matrix form as

$$\{\sigma\} = [Q]\{\varepsilon\} \quad (3.9)$$

Where  $[Q]$  is symmetric as before, so that the off-diagonal stiffness terms are defined as  $Q_{ij} = Q_{ji}$ .

If we think of the  $X_1$  and  $X_2$  axes as coordinates in the plane of the lamina, where the  $X_1$  axis aligns with the fiber reinforcement, the  $X_2$  axis is transverse to the fibers and the  $X_3$  axis is then normal to the  $(X_1, X_2)$  plane, these axes are sketched below.

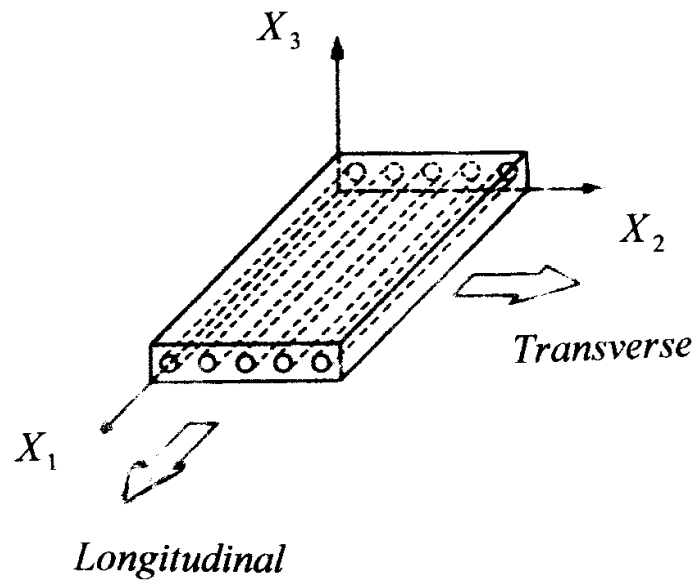

**Figure 3.2. Natural (Material) Coordinates of Unidirectionally Reinforced Lamina**

The ply (lamina) depicted above shows only one fiber through the ply thickness. This is atypical as there are normally several fibers through the thickness of a typical ply. Note that in developing all of the formulation presented herein, the  $(L, T)$  axes are interchangeable with the  $(X_1, X_2)$  axes and  $T'$  aligns with the  $X_3$  axis.

A more typical cross section of a composite taken from a single ply is shown in the photograph (Figure 3.3) below.

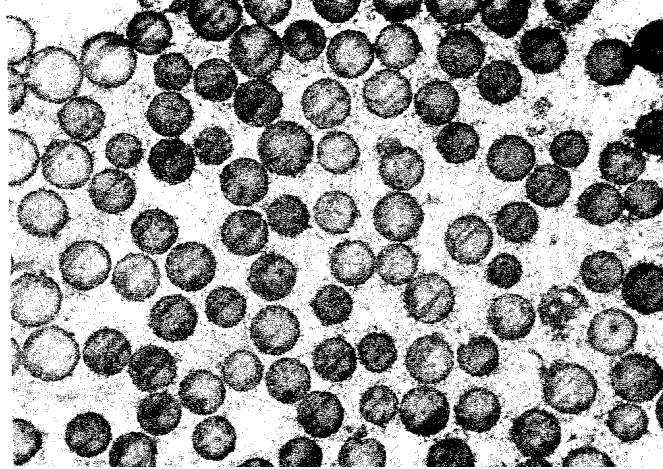

**Figure 3.3. Typical Fiber Distribution in Unidirectionally Reinforced Lamina (Ply)**

An important factor in determining the stiffness and strength properties of composite materials is the relative proportion of matrix to reinforcing materials. These proportions can be quantified as either weight fractions or volume fractions. The volume fiber fraction is defined as

$$V_f = v_f / v_c \quad (3.10)$$

Here  $v_f$  is the volume of fibers and  $v_c$  is the associated volume of composite. Similarly, the weight fiber fraction is given as

$$W_f = w_f / w_c \quad (3.11)$$

where  $w_f$  is weight of fibers and  $w_c$  is the associated weight of composite.

The stress tensor contains the terms  $\sigma_1, \sigma_2, \sigma_3, \tau_{12}, \tau_{23}, \tau_{31}$  and the strain tensor contains the terms  $\varepsilon_1, \varepsilon_2, \varepsilon_3, \gamma_{12}, \gamma_{23}, \gamma_{31}$ , respectively. Here,  $\gamma_{ij}$  are the engineering shear strains. Note the relationship

$$\gamma_{ij} = 2\varepsilon_{ij} \quad (3.12)$$

where  $\varepsilon_{ij}$  are the tensorial shear strains.

If we assume that we have one plane of material symmetry,  $X_3=0$ , i.e., the  $X_1, X_2$  plane, then the constitutive equations can be written in matrix form as

$$\begin{Bmatrix} \sigma_1 \\ \sigma_2 \\ \sigma_3 \\ \tau_{23} \\ \tau_{31} \\ \tau_{12} \end{Bmatrix} = \begin{bmatrix} Q_{11} & Q_{12} & Q_{13} & 0 & 0 & Q_{16} \\ Q_{21} & Q_{22} & Q_{23} & 0 & 0 & Q_{26} \\ Q_{31} & Q_{32} & Q_{33} & 0 & 0 & Q_{36} \\ 0 & 0 & 0 & Q_{44} & Q_{45} & 0 \\ 0 & 0 & 0 & Q_{54} & Q_{55} & 0 \\ Q_{61} & Q_{62} & Q_{63} & 0 & 0 & Q_{66} \end{bmatrix} \begin{Bmatrix} \epsilon_1 \\ \epsilon_2 \\ \epsilon_3 \\ \gamma_{23} \\ \gamma_{31} \\ \gamma_{12} \end{Bmatrix} \quad (3.13)$$

Thus no normal (extensional) stresses are produced by the out-of-plane  $(\gamma_{23}, \gamma_{31})$  shear stresses. Due to symmetry in the  $Q_{ij}$  constitutive terms, we have reduced the number of independent material constants from 21 to 13.

As noted the coordinates  $X_1$ ,  $X_2$ , and  $X_3$  align with the material (natural) coordinates, we have  $X_1$  aligning with the fiber direction,  $X_2$  is transverse to the fiber direction and  $X_3$  is normal to the plane of the lamina. This coordinate alignment results in the  $(X_2, X_3)$  plane becoming an additional plane of symmetry. In these natural coordinates stresses  $\sigma_1, \sigma_2$  and  $\sigma_3$  do not produce in-plane shear strain  $\gamma_{12}$ , and out-of-plane shear stresses  $\tau_{23}$  and  $\tau_{31}$  become decoupled. In these natural coordinates, the constitutive equations reduce to

$$\begin{Bmatrix} \sigma_1 \\ \sigma_2 \\ \sigma_3 \\ \tau_{23} \\ \tau_{31} \\ \tau_{12} \end{Bmatrix} = \begin{bmatrix} Q_{11} & Q_{12} & Q_{13} & 0 & 0 & 0 \\ Q_{21} & Q_{22} & Q_{23} & 0 & 0 & 0 \\ Q_{31} & Q_{32} & Q_{33} & 0 & 0 & 0 \\ 0 & 0 & 0 & Q_{44} & 0 & 0 \\ 0 & 0 & 0 & 0 & Q_{55} & 0 \\ 0 & 0 & 0 & 0 & 0 & Q_{66} \end{bmatrix} \begin{Bmatrix} \epsilon_1 \\ \epsilon_2 \\ \epsilon_3 \\ \gamma_{23} \\ \gamma_{31} \\ \gamma_{12} \end{Bmatrix} \quad (3.14)$$

We now have reduced the number of independent material constants to 9 for the 3D case of an orthotropic material, i.e., utilizing material (natural) coordinates for the lamina.

If we consider the special case of a 2D orthotropic material and continue to use the material (natural) coordinates, the constitutive equations simply reduce to

$$\begin{Bmatrix} \sigma_1 \\ \sigma_2 \\ \tau_{12} \end{Bmatrix} = \begin{bmatrix} Q_{11} & Q_{12} & 0 \\ Q_{21} & Q_{22} & 0 \\ 0 & 0 & Q_{66} \end{bmatrix} \begin{Bmatrix} \epsilon_1 \\ \epsilon_2 \\ \gamma_{12} \end{Bmatrix} \quad (3.15)$$

In this case, there are only 4 independent material constants. This particular material case can be described as a specially orthotropic lamina.

**Inversion** of the constitutive matrix  $[Q]$  gives the strains as a function of stresses. In matrix form we have

$$\{\boldsymbol{\varepsilon}\} = [S]\{\boldsymbol{\sigma}\} \quad (3.16)$$

where  $[S] = [Q]^{-1}$ , and  $[S]$  is denoted the compliance matrix. In expanded matrix form this becomes

$$\begin{Bmatrix} \varepsilon_1 \\ \varepsilon_2 \\ \gamma_{12} \end{Bmatrix} = \begin{bmatrix} S_{11} & S_{12} & 0 \\ S_{21} & S_{22} & 0 \\ 0 & 0 & S_{66} \end{bmatrix} \begin{Bmatrix} \sigma_1 \\ \sigma_2 \\ \tau_{12} \end{Bmatrix} \quad (3.17)$$

For the specially orthotropic lamina where the reference axes coincide with the material axes of symmetry, the engineering constants can be defined in more familiar terms. The  $X_1, X_2$  axes become the  $L$ - $T$  axes and the  $X_3$  axis becomes the  $T'$  axis as shown in the sketch below (Figure 3.4). The  $L$ - $T$  axes are in the plane of the lamina, where the longitudinal  $L$  axis is directed along the fibers and the transverse  $T$  axis is directed perpendicular to the fiber reinforcement. The  $T'$  axis is normal to the plane of the lamina (often referred to as the through-the-thickness direction).

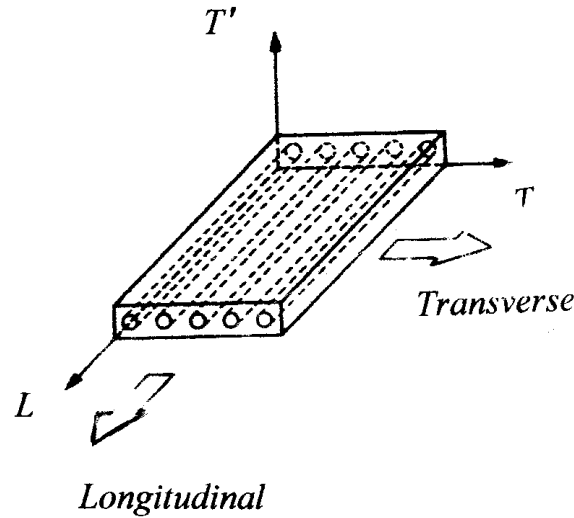

**Figure 3.4. Longitudinal, Transverse and Through-The-Thickness Axes, Unidirectionally Reinforced Lamina**

The engineering constants are defined as

$E_L$  = Elastic modulus in longitudinal (along the fibers) direction

$E_T$  = Elastic modulus transverse to the fiber direction

$\nu_{LT}$  = Major Poisson's ratio (transverse strain produced by longitudinal stress)

$\nu_{TL}$  = Minor Poisson's ratio (longitudinal strain produced by transverse stress)

The compliance terms in  $[S]$  can be defined in terms of these engineering constants as

$$\begin{aligned}
S_{11} &= \frac{1}{E_L} \\
S_{22} &= \frac{1}{E_T} \\
S_{12} &= -\frac{\nu_{LT}}{E_L} = -\frac{\nu_{TL}}{E_T} \\
S_{66} &= \frac{1}{G_{LT}}
\end{aligned} \tag{3.18}$$

Thus in matrix form we have

$$\begin{Bmatrix} \varepsilon_L \\ \varepsilon_T \\ \gamma_{LT} \end{Bmatrix} = \begin{bmatrix} \frac{1}{E_L} & -\frac{\nu_{TL}}{E_T} & 0 \\ -\frac{\nu_{LT}}{E_L} & \frac{1}{E_T} & 0 \\ 0 & 0 & \frac{1}{G_{LT}} \end{bmatrix} \begin{Bmatrix} \sigma_L \\ \sigma_T \\ \tau_{LT} \end{Bmatrix} \tag{3.19}$$

Since  $[Q] = [S]^{-1}$  the constitutive (stiffness) terms can be defined by inverting  $[S]$

$$\begin{aligned}
Q_{11} &= \frac{E_L}{1 - \nu_{LT}\nu_{TL}} \\
Q_{22} &= \frac{E_T}{1 - \nu_{LT}\nu_{TL}} \\
Q_{12} &= \frac{\nu_{LT}E_T}{1 - \nu_{LT}\nu_{TL}} = \frac{\nu_{TL}E_L}{1 - \nu_{LT}\nu_{TL}} \\
Q_{66} &= G_{LT}
\end{aligned} \tag{3.20}$$

As an example, these engineering constants for Carbon/Epoxy AS/H3501 are given as

$$E_L = 138 \text{ GPa}, E_T = 8.96 \text{ GPa}, G_{LT} = 7.10 \text{ GPa and } \nu_{LT} = 0.3$$

We know that we have symmetry such that  $Q_{ij} = Q_{ji}$  and  $S_{ij} = S_{ji}$ . Therefore,

$$\frac{\nu_{TL}}{E_T} = \frac{\nu_{LT}}{E_L} \quad (3.21)$$

Thus if the major Poisson's ratio  $\nu_{LT}$  is known, then the Minor Poisson's ratio is determined from

$$\nu_{TL} = \frac{E_T}{E_L} \nu_{LT} \quad (3.22)$$

and only 4 independent material constants  $E_L$ ,  $E_T$ ,  $G_{LT}$ , and  $\nu_{LT}$  are needed to specify the behavior of a specially orthotropic lamina.

#### 4.0 RESTRICTIONS ON ELASTIC CONSTANTS

More experimental measurements are needed to characterize the behavior of an orthotropic material relative to an isotropic material. For the various materials we have

- 3D Orthotropic, need 9 independent constants
- 2D Orthotropic, need 4 independent constants
- Isotropic, need only 2 independent constants

For an isotropic material, we have a relationship between Young's modulus, shear modulus and Poisson's ratio, i.e.,  $G = E/2(1 + \nu)$ . Thus we need only two of the three material constants to determine the third.

A unidirectional fiber composite can be considered to be transversely isotropic. Consider the  $L-T-T'$  coordinate system where  $T'$  is normal to the  $LT$  (lamina) plane. The material constants are related as below

$$E_T = E_{T'}$$

$$G_{LT} = G_{LT'}$$

$$\nu_{LT} = \nu_{LT'}$$

and

$$G_{TT'} = \frac{E_T}{2(1 + \nu_{TT'})}$$

Therefore in this case we have 5 independent constants ( $E_L, E_T, G_{LT}, \nu_{LT}, \text{and } \nu_{TT'}$ ).

Constraints for isotropic materials are that  $E$ ,  $G$ , and  $K$  are all positive, where  $K$  is the Bulk modulus. Also

$$-1 \leq \nu \leq 0.5$$

Remember that

$$G = \frac{E}{2(1+\nu)} ; \quad \text{thus } \nu \geq -1 \quad \text{for } G > 0$$

and

$$K = \frac{E}{3(1-2\nu)} ; \quad \text{thus } \nu \leq \frac{1}{2} \quad \text{for } K > 0$$

Similar constraints exist for orthotropic materials and are defined as follows

$$S_{ii} > 0 \quad \text{and} \quad Q_{ii} > 0$$

Which is the same as

$$E_1, E_2, E_3, G_{12}, G_{13}, G_{23} > 0$$

or equivalently

$$E_L, E_T, E_{T'}, G_{LT}, G_{LT'}, G_{TT'} > 0$$

all essentially the same constraints. The following constraints are also required

$$\begin{aligned} (1 - \nu_{LT}\nu_{TL}) &> 0 \\ (1 - \nu_{LT'}\nu_{T'L}) &> 0 \\ (1 - \nu_{TT'}\nu_{T'T}) &> 0 \end{aligned} \quad (4.1)$$

These constraints are required because, e.g.,  $Q_{11} = \frac{E_L}{(1 - \nu_{LT}\nu_{TL})} > 0$ .

Since we have the previously shown relationship

$$\frac{\nu_{LT}}{E_L} = \frac{\nu_{TL}}{E_T} \quad (3.21)$$

We can combine (3.21) with the first equation in (4.1) to give a constraint of the form

$$|\nu_{LT}| < \left( \frac{E_L}{E_T} \right)^{1/2}$$

similarly we have the additional constraints

$$|\nu_{LT}| < \left( \frac{E_L}{E_T} \right)^{1/2} ; |\nu_{LT'}| < \left( \frac{E_L}{E_{T'}} \right)^{1/2} ; |\nu_{TL}| < \left( \frac{E_{T'}}{E_L} \right)^{1/2} ; |\nu_{TT'}| < \left( \frac{E_T}{E_{T'}} \right)^{1/2} ; |\nu_{TT}| < \left( \frac{E_{T'}}{E_T} \right)^{1/2}$$

The preceding constraints can be used to great benefit to evaluate experimental data. For example, tensile testing both in the longitudinal ( $L$ ) and transverse ( $T$ ) directions gives  $E_L, \nu_{LT}$  from longitudinal loading and  $E_T, \nu_{TL}$  from the transverse loading. A check on

the validity of the data requires that the constraint equations  $|\nu_{LT}| < \left( \frac{E_L}{E_T} \right)^{1/2}$  and

$$|\nu_{TL}| < \left( \frac{E_T}{E_L} \right)^{1/2} \text{ be satisfied.}$$

## 5.0 STRESS-STRAIN RELATIONS FOR GENERALLY ORTHOTROPIC LAMINA

Consider laminated composite structures that are constructed by stacking a number of unidirectional lamina (plies) in a specified orientation sequence. Thus the principal material (natural) coordinates of each lamina can be oriented at a different angle with respect to a common reference coordinate system. The behavior of each lamina can be described by the previously derived stress-strain relations in terms of the material (natural) axes. For the purpose of analyzing laminated composite structures, it is necessary to refer the stress-strain relations to a convenient reference coordinate system. Thus we need to derive the stiffness and compliance matrices for an orthotropic lamina in terms of arbitrary axes. A lamina referred to arbitrary axes is called a generally orthotropic lamina.

The principal material  $L$ - $T$  axes of each orthotropic lamina are oriented at an angle  $\theta$  with respect to a common set of reference  $X$ - $Y$  axes, as sketched below.

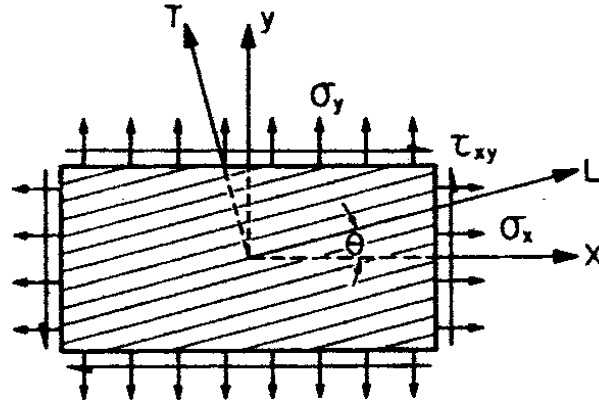

**Figure 5.1. Orthotropic Lamina with Oriented Fiber Reinforcement**

The following transformation relations can be derived from equilibrium relating stresses and strains in X-Y coordinates to L-T coordinates.

$$\begin{Bmatrix} \sigma_L \\ \sigma_T \\ \tau_{LT} \end{Bmatrix} = [T] \begin{Bmatrix} \sigma_X \\ \sigma_Y \\ \tau_{XY} \end{Bmatrix} \quad (5.1)$$

and

$$\begin{Bmatrix} \epsilon_L \\ \epsilon_T \\ \frac{1}{2}\gamma_{LT} \end{Bmatrix} = [T] \begin{Bmatrix} \epsilon_X \\ \epsilon_Y \\ \frac{1}{2}\gamma_{XY} \end{Bmatrix} \quad (5.2)$$

Here, the transformation matrix  $[T]$  is defined as

$$\begin{bmatrix} c^2 & s^2 & 2sc \\ s^2 & c^2 & -2sc \\ -sc & sc & (c^2 - s^2) \end{bmatrix} \quad (5.3)$$

where  $c = \cos(\theta)$  and  $s = \sin(\theta)$ .

Inversion gives the relation between stresses and strains in material  $L-T$  coordinates to those in  $X-Y$  coordinates. We have

$$\begin{Bmatrix} \sigma_X \\ \sigma_Y \\ \tau_{XY} \end{Bmatrix} = [T]^{-1} \begin{Bmatrix} \sigma_L \\ \sigma_T \\ \tau_{LT} \end{Bmatrix} \quad (5.4)$$

and

$$\begin{Bmatrix} \epsilon_X \\ \epsilon_Y \\ \frac{1}{2}\gamma_{XY} \end{Bmatrix} = [T]^{-1} \begin{Bmatrix} \epsilon_L \\ \epsilon_T \\ \frac{1}{2}\gamma_{LT} \end{Bmatrix} \quad (5.5)$$

and the inverted transformation matrix  $[T]^{-1}$  is defined as

$$\begin{bmatrix} c^2 & s^2 & -2sc \\ s^2 & c^2 & 2sc \\ sc & -sc & (c^2 - s^2) \end{bmatrix} \quad (5.6)$$

We have the stress-strain relationships for generally orthotropic laminas in natural (material) coordinates. It is useful to have these relationships defined in the reference XY coordinates as well. In order to derive the relationship between strain and stress in XY coordinates, first substitute (5.1) into (3.19) giving

$$\begin{Bmatrix} \epsilon_L \\ \epsilon_T \\ \gamma_{LT} \end{Bmatrix} = [S][T] \begin{Bmatrix} \sigma_X \\ \sigma_Y \\ \tau_{XY} \end{Bmatrix} \quad (5.7)$$

We can introduce a useful transformation between tensorial and engineering shear strains as below

$$\begin{Bmatrix} \epsilon_L \\ \epsilon_T \\ \gamma_{LT} \end{Bmatrix} = [R] \begin{Bmatrix} \epsilon_L \\ \epsilon_T \\ \frac{1}{2}\gamma_{LT} \end{Bmatrix} \quad (5.8)$$

where

$$[R] = \begin{bmatrix} 1 & 0 & 0 \\ 0 & 1 & 0 \\ 0 & 0 & 2 \end{bmatrix} \quad (5.9)$$

Substituting (5.8) into (5.7) gives

$$[R] \begin{Bmatrix} \varepsilon_L \\ \varepsilon_T \\ \frac{1}{2} \gamma_{LT} \end{Bmatrix} = [S][T] \begin{Bmatrix} \sigma_X \\ \sigma_Y \\ \tau_{XY} \end{Bmatrix} \quad (5.10)$$

Now substituting (5.2) into the left hand side of (5.10) yields

$$[R][T] \begin{Bmatrix} \varepsilon_X \\ \varepsilon_Y \\ \frac{1}{2} \gamma_{XY} \end{Bmatrix} = [S][T] \begin{Bmatrix} \sigma_X \\ \sigma_Y \\ \tau_{XY} \end{Bmatrix} \quad (5.11)$$

The transformation matrix  $[R]$  can also be used to define the transformation

$$\begin{Bmatrix} \varepsilon_X \\ \varepsilon_Y \\ \frac{1}{2} \gamma_{XY} \end{Bmatrix} = [R]^{-1} \begin{Bmatrix} \varepsilon_X \\ \varepsilon_Y \\ \gamma_{XY} \end{Bmatrix} \quad (5.12)$$

where

$$[R]^{-1} = \begin{bmatrix} 1 & 0 & 0 \\ 0 & 1 & 0 \\ 0 & 0 & \frac{1}{2} \end{bmatrix} \quad (5.13)$$

Substituting (5.12) into the left hand side of (5.11) gives

$$[R][T][R]^{-1} \begin{Bmatrix} \varepsilon_X \\ \varepsilon_Y \\ \gamma_{XY} \end{Bmatrix} = [S][T] \begin{Bmatrix} \sigma_X \\ \sigma_Y \\ \tau_{XY} \end{Bmatrix} \quad (5.14)$$

Simply rearranging the matrix relationship above gives

$$\begin{Bmatrix} \boldsymbol{\varepsilon}_X \\ \boldsymbol{\varepsilon}_Y \\ \boldsymbol{\gamma}_{XY} \end{Bmatrix} = [\mathbf{R}][\mathbf{T}]^{-1}[\mathbf{R}]^{-1}[\mathbf{S}][\mathbf{T}] \begin{Bmatrix} \boldsymbol{\sigma}_X \\ \boldsymbol{\sigma}_Y \\ \boldsymbol{\tau}_{XY} \end{Bmatrix} \quad (5.15)$$

It is easily shown that the transpose of  $[\mathbf{T}]$  can be defined as

$$[\mathbf{T}]^T = [\mathbf{R}][\mathbf{T}]^{-1}[\mathbf{R}]^{-1} \quad (5.16)$$

Substituting (5.16) into (5.15) yields the simplified strain-stress relationship in reference  $X$ - $Y$  coordinates.

$$\begin{Bmatrix} \boldsymbol{\varepsilon}_X \\ \boldsymbol{\varepsilon}_Y \\ \boldsymbol{\gamma}_{XY} \end{Bmatrix} = [\bar{\mathbf{S}}] \begin{Bmatrix} \boldsymbol{\sigma}_X \\ \boldsymbol{\sigma}_Y \\ \boldsymbol{\tau}_{XY} \end{Bmatrix} \quad (5.17)$$

where

$$[\bar{\mathbf{S}}] = [\mathbf{T}]^T [\mathbf{S}] [\mathbf{T}] \quad (5.18)$$

Note that the compliance matrix  $[\bar{\mathbf{S}}]$  is fully populated and is herein represented as

$$[\bar{\mathbf{S}}] = \begin{bmatrix} \bar{S}_{11} & \bar{S}_{12} & \bar{S}_{16} \\ \bar{S}_{12} & \bar{S}_{22} & \bar{S}_{26} \\ \bar{S}_{16} & \bar{S}_{26} & \bar{S}_{66} \end{bmatrix} \quad (5.19)$$

Relating stress to strain in the reference  $XY$  coordinates follows by inverting (5.17)

$$\begin{Bmatrix} \boldsymbol{\sigma}_X \\ \boldsymbol{\sigma}_Y \\ \boldsymbol{\tau}_{XY} \end{Bmatrix} = [\bar{\mathbf{S}}]^{-1} \begin{Bmatrix} \boldsymbol{\varepsilon}_X \\ \boldsymbol{\varepsilon}_Y \\ \boldsymbol{\gamma}_{XY} \end{Bmatrix} \quad (5.20)$$

or simply

$$\begin{Bmatrix} \boldsymbol{\sigma}_X \\ \boldsymbol{\sigma}_Y \\ \boldsymbol{\tau}_{XY} \end{Bmatrix} = [\bar{\mathbf{Q}}] \begin{Bmatrix} \boldsymbol{\varepsilon}_X \\ \boldsymbol{\varepsilon}_Y \\ \boldsymbol{\gamma}_{XY} \end{Bmatrix} \quad (5.21)$$

where

$$[\bar{\mathbf{Q}}] = [\bar{\mathbf{S}}]^{-1} = [\mathbf{T}]^{-1}[\mathbf{S}]^{-1}[\mathbf{T}]^{-T} \quad (5.22)$$

As with the compliance matrix in the reference X-Y coordinate system, the stiffness matrix  $[\bar{Q}]$  is fully populated and can be written as

$$[\bar{Q}] = \begin{bmatrix} \bar{Q}_{11} & \bar{Q}_{12} & \bar{Q}_{16} \\ \bar{Q}_{12} & \bar{Q}_{22} & \bar{Q}_{26} \\ \bar{Q}_{16} & \bar{Q}_{26} & \bar{Q}_{66} \end{bmatrix} \quad (5.23)$$

The stiffness terms in  $[\bar{Q}]$  are related to the 4 independent terms in  $[Q]$  as given below.

$$\begin{aligned} \bar{Q}_{11} &= Q_{11}c^4 + Q_{22}s^4 + 2(Q_{12} + 2Q_{66})s^2c^2 \\ \bar{Q}_{22} &= Q_{11}s^4 + Q_{22}c^4 + 2(Q_{12} + 2Q_{66})s^2c^2 \\ \bar{Q}_{12} &= (Q_{11} + Q_{22} - 4Q_{66})s^2c^2 + Q_{12}(c^4 + s^4) \\ \bar{Q}_{66} &= (Q_{11} + Q_{22} - 2Q_{12} - 2Q_{66})s^2c^2 + Q_{66}(s^4 + c^4) \\ \bar{Q}_{16} &= (Q_{11} - Q_{12} - 2Q_{66})c^3s - (Q_{22} - Q_{12} - 2Q_{66})cs^3 \\ \bar{Q}_{26} &= (Q_{11} - Q_{12} - 2Q_{66})cs^3 - (Q_{22} - Q_{12} - 2Q_{66})c^3s \end{aligned} \quad (5.24)$$

Similarly, the compliance terms in  $[\bar{S}]$  are related to the 4 independent terms in  $[S]$  as written below.

$$\begin{aligned} \bar{S}_{11} &= S_{11}c^4 + S_{22}s^4 + (2S_{12} + S_{66})s^2c^2 \\ \bar{S}_{22} &= S_{11}s^4 + S_{22}c^4 + (2S_{12} + S_{66})s^2c^2 \\ \bar{S}_{12} &= (S_{11} + S_{22} - S_{66})c^2s^2 + S_{12}(c^4 + s^4) \\ \bar{S}_{66} &= 2(2S_{11} + 2S_{22} - 4S_{12} - S_{66})c^2s^2 + S_{66}(c^4 + s^4) \\ \bar{S}_{16} &= (2S_{11} - 2S_{12} - S_{66})c^3s - (2S_{22} - 2S_{12} - S_{66})cs^3 \\ \bar{S}_{26} &= (2S_{11} - 2S_{12} - S_{66})cs^3 - (2S_{22} - 2S_{12} - S_{66})c^3s \end{aligned} \quad (5.25)$$

As an example of calculating stresses consider the lamina shown below

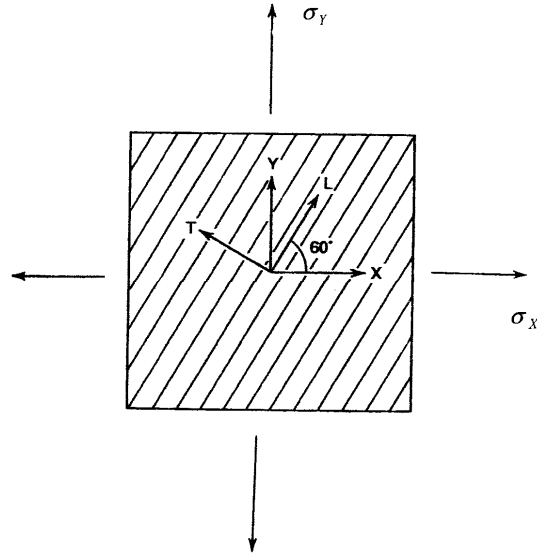

**Figure 5.2. Stresses  $\sigma_x$  and  $\sigma_y$  Applied to Angled Ply,  
Fiber Orientation  $\theta = 60^\circ$**

Assume that we know the stress values in X-Y coordinates and that the lamina is a typical E-glass epoxy composite material. Stresses have values

$$\sigma_x = 20\text{MPa}(2.9\text{Kpsi})$$

and

$$\sigma_y = 40\text{MPa}(5.8\text{Kpsi})$$

The E-glass epoxy properties are given as

$$V_f = 0.45 \quad (\text{volume fiber fraction})$$

$$\rho = 1.8\text{g/cm}^3 \quad (\text{density})$$

$$E_L = 38.6\text{GPa}(5.6\text{MPsi})$$

$$E_T = 8.27\text{GPa}(1.20\text{MPsi})$$

$$G_{LT} = 4.14\text{GPa}(0.60\text{MPsi})$$

$$\nu_{LT} = 0.26$$

Note that the fibers are orientated at  $60^\circ$  to the X coordinate axis. We determine the stresses in natural ( $L-T$ ) coordinates by applying equation (5.1)

$$\begin{Bmatrix} \sigma_L \\ \sigma_T \\ \tau_{LT} \end{Bmatrix} = \begin{bmatrix} 0.25 & 0.75 & 0.866 \\ 0.75 & 0.25 & -0.866 \\ -0.433 & 0.433 & -0.5 \end{bmatrix} \begin{Bmatrix} 20 \\ 40 \\ 0 \end{Bmatrix} = \begin{Bmatrix} 35 \\ 25 \\ 8.66 \end{Bmatrix} \text{ MPa}$$

The strains in natural coordinates are easily obtained from equation (3.19) as given below

$$\begin{Bmatrix} \varepsilon_L \\ \varepsilon_T \\ \gamma_{LT} \end{Bmatrix} = \begin{bmatrix} 2.591E-11 & -6.736E-12 & 0 \\ -6.736E-12 & 1.209E-10 & 0 \\ 0 & 0 & 2.415E-10 \end{bmatrix} \begin{Bmatrix} 35E+6 \\ 25E+6 \\ 8.66E+6 \end{Bmatrix} = \begin{Bmatrix} 738 \\ 2790 \\ 2092 \end{Bmatrix} \mu\varepsilon$$

Failure theories for orthotropic lamina are generally defined in terms of the natural (material) coordinates and therefore it is essential in designing laminated composite structures to be able to apply the coordinate transformations as just demonstrated.

It can be shown that strains in  $X$ - $Y$  coordinates are related to strains in natural  $L$ - $T$  coordinates through the transformation

$$\begin{Bmatrix} \varepsilon_X \\ \varepsilon_Y \\ \gamma_{XY} \end{Bmatrix} = [T]^T \begin{Bmatrix} \varepsilon_L \\ \varepsilon_T \\ \gamma_{LT} \end{Bmatrix} \quad (5.26)$$

Thus in the present example, the strains in  $X$ - $Y$  coordinates are given as

$$\begin{Bmatrix} \varepsilon_X \\ \varepsilon_Y \\ \gamma_{XY} \end{Bmatrix} = \begin{bmatrix} 0.25 & 0.75 & -0.433 \\ 0.75 & 0.25 & 0.433 \\ 0.866 & -0.866 & -0.5 \end{bmatrix} \begin{Bmatrix} 738 \\ 2790 \\ 2092 \end{Bmatrix} = \begin{Bmatrix} 1371 \\ 2156 \\ -2823 \end{Bmatrix} \mu\varepsilon$$

## 6.0 BIAXIAL STRENGTH THEORIES FOR ORTHOTROPIC LAMINA

For failure criteria to have validity, they must be able to predict the strength of materials under multi-axial loading conditions based on data obtained from a set of simplified loading tests. Failure criteria for isotropic materials are written in terms of principal stresses in combination with ultimate tensile, compressive and shear strengths. Thus applying failure theories in the design of isotropic materials requires that these three strength quantities be known.

The situation is considerably more complex in the case of orthotropic materials. For these engineered materials, both strength as well as stiffness (constitutive) properties are direction dependent. For design purposes, the failure theories are generally based on five *in-plane* strength quantities defined in natural (material) coordinates. These strength quantities are herein defined as

$\sigma_{LU}$  = Longitudinal tensile strength (in the direction of fiber reinforcement)

$\sigma_{TU}$  = Transverse tensile strength (normal to the direction of fiber reinforcement)

$\tau_{LTU}$  = Shear strength in the plane of the lamina

$\sigma'_{LU}$  = Longitudinal compressive strength

$\sigma'_{TU}$  = Transverse compressive strength

One of the failure theories presented later includes the transverse (out-of-plane) shear strength  $\tau_{TT'U}$  in the formulation even for the 2-D biaxial stress state considered here. There is also the possibility of utilizing an additional strength quantity based on experiments involving the application of a biaxial state of stress.

The longitudinal and transverse stiffness and strength properties can be obtained through uniaxial testing of unidirectionally reinforced composite specimens. These tests involve loading specimens along natural (material) coordinates. Uniaxial tension testing serves to determine the longitudinal and transverse moduli  $E_L$  and  $E_T$ , tensile strength values  $\sigma_{LU}$  and  $\sigma_{TU}$ , as well as Poisson's ratios  $\nu_{LT}$  and  $\nu_{TL}$ . Uniaxial compression tests are more difficult to perform than uniaxial tension tests because the test must be designed to prevent out of plane buckling and also to prevent edge damage. However, various test methods do exist to overcome these difficulties. Thus uniaxial compression testing is used to obtain the compressive strength values  $\sigma'_{LU}$  and  $\sigma'_{TU}$ . In-plane shear stiffness  $G_{LT}$  and shear strength  $\tau_{LTU}$  values can be obtained from a number of different types of tests, including torsion tube [1], rail shear [2], Iosipescu [3,4], Arcan [5], 10° off-axis specimen [6] and ±45° specimen [7]. As noted in [7], the ±45° specimen does not require any specialized fixtures and is therefore used often to determine the in-plane shear stress-strain response of composite materials. The relevant test method is ASTM D3518/D3518M-94(2001) Standard Test Method for “*In-Plane Shear Response of Polymer Matrix Composite Materials by Tensile Test of ±45° Laminate*”. This standard test method is based on measuring the uniaxial stress-strain response of a ±45° laminate which is symmetrically laminated about the mid-plane. Obtaining shear stress/strain data using the 10° off-axis specimen requires that oblique end tabs be used in order to achieve a homogeneous strain field over the entire specimen [8-10].

Since failure theories for composite materials involve strengths in material  $L$ - $T$  coordinates, design calculations require transformation of the stress field from some  $X$ - $Y$  coordinate system to  $L$ - $T$  coordinates. Failure criteria used in the design of composite materials are thus written in terms of stresses in material coordinates rather than in terms of principal stresses, as is the case for isotropic materials.

It may be obvious but is useful to point out that a uniaxial stress applied in any off-axis direction, i.e., not along a material axis, produces a multiaxial stress state in  $L$ - $T$  coordinates. Therefore, an appropriate failure theory must be used even for this simple loading condition. Failure theories for orthotropic materials can be represented as theoretical failure envelopes in stress space. These failure envelopes are similar to yield surface envelopes used to represent the termination of linear elastic behavior for isotropic materials. A number of strength (failure) theories, widely used in the design of fiber reinforced composite structures, will now be presented. These approaches can be broken into separable theories, i.e., those that can identify the mode of failure, and those that are more generalized in that they identify a failure limit but do not separate out or identify any particular failure mode. An estimation of the use of various failure criteria by people working in the composites design field has been reported, see Paris [11]. This estimation rated the relative utilization of the various criteria as follows: maximum strain 30% use; maximum stress 23% use; Tsai-Hill 18% use; Tsai-Wu 13% use; and all others 19% use. The maximum strain and maximum stress failure theories are herein denoted as separable failure theories, whereas the Tsai-Hill and Tsai-Wu failure theories are denoted as generalized failure theories. Two other failure theories to be presented herein, which are included in “all others” regarding their utilization by designers, are denoted the Hashin failure theory and the Chang failure theory. Each of these failure theories are defined as separable failure theories. It is interesting to note that in a review of research papers the majority of researchers base their proposals on variations of Hashin’s criteria [11].

## 6.1 Separable Strength (Failure) Theories

### 6.1.1 Maximum Stress Theory

In this theory the notion is that failure occurs if any of the stresses in the natural (material) coordinates exceeds the corresponding allowable stress. In order to avoid failure, the following inequalities must be satisfied

$$\begin{aligned}\sigma_L &< \sigma_{LU} \\ \sigma_T &< \sigma_{TU} \\ \tau_{LT} &< \tau_{LTU}\end{aligned}\quad (6.1)$$

When the normal stresses are compressive,  $\sigma_{LU}$  and  $\sigma_{TU}$  are replaced with the allowable compressive stresses as below

$$\begin{aligned}\sigma_L &< \sigma'_{LU} \\ \sigma_T &< \sigma'_{TU}\end{aligned}\quad (6.2)$$

Note that in this failure criterion there is assumed to be no interaction between the axial and shear modes of failure. This over simplification can lead to an over prediction of allowable strength.

As an example of applying this failure theory, consider the E-glass epoxy material of the previous example. The strength properties are given as

$$\sigma_{LU} = 1062MPa(154.1KPsi)$$

$$\sigma'_{LU} = 610MPa(88.5KPsi)$$

$$\sigma_{TU} = 31MPa(4.5KPsi)$$

$$\sigma'_{TU} = 118MPa(17.1KPsi)$$

$$\tau_{LTU} = 72MPa(10.45KPsi)$$

Consider an orthotropic lamina subjected to a stress  $\sigma_x$  making an angle  $\theta$  with the longitudinal fiber direction as illustrated in the sketch below.

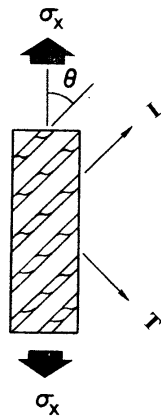

**Figure 6.1. Unidirectionally Loaded Lamina with Offset Angle  $\theta$**

The applied stress is transformed to material coordinates using equation (5.1), we have

$$\begin{Bmatrix} \sigma_L \\ \sigma_T \\ \tau_{LT} \end{Bmatrix} = [T] \begin{Bmatrix} \sigma_x \\ 0 \\ 0 \end{Bmatrix} = \begin{Bmatrix} \sigma_x \cos^2 \theta \\ \sigma_x \sin^2 \theta \\ -\sigma_x \sin \theta \cos \theta \end{Bmatrix} \quad (6.3)$$

Combining (6.3) with the maximum stress criteria represented in (6.1) and (6.2) gives the following inequalities, normalized by  $\sigma_{LU}$ .

$$\frac{\sigma_X}{\sigma_{LU}} < \frac{1}{\cos^2 \theta}$$

$$\frac{\sigma_X}{\sigma_{LU}} < \frac{\sigma_{TU}}{\sigma_{LU} \sin^2 \theta} \quad (6.4)$$

$$\frac{\sigma_X}{\sigma_{LU}} < \frac{\tau_{LTU}}{\sigma_{LU} \sin \theta \cos \theta}$$

When the applied stress is compressive, the first two of these inequalities become

$$\frac{\sigma_X}{\sigma_{LU}} < \frac{\sigma'_{LU}}{\sigma_{LU} \cos^2 \theta}$$

(6.5)

$$\frac{\sigma_X}{\sigma_{LU}} < \frac{\sigma'_{TU}}{\sigma_{LU} \sin^2 \theta}$$

For any particular value of  $\theta$ , the inequality giving the lowest value of strength is the appropriate failure prediction. The off-axis strength predictions using the maximum stress criteria are plotted below for values of  $\theta$  ranging from  $0^\circ$  to  $90^\circ$ . The strength results are plotted in terms of normalized stress  $\sigma_X / \sigma_{LU}$ .

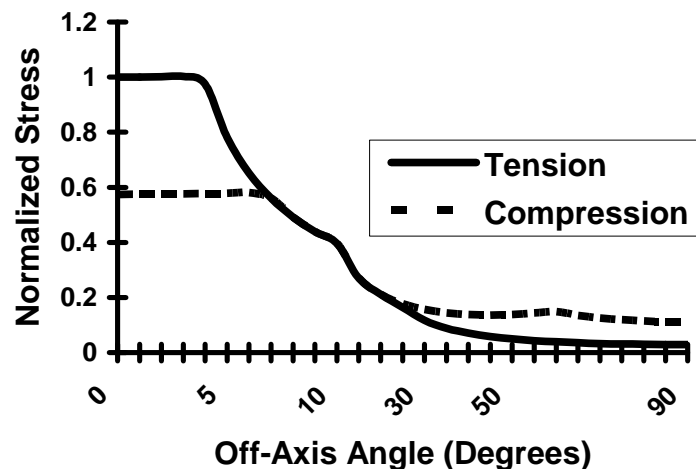

**Figure 6.2. Normalized Stress  $\sigma_X / \sigma_{LU}$  Related to Off-Axis Angle  $\theta$ , Maximum Stress Failure Theory**

At small values of  $\theta$  the load is parallel or nearly parallel with the longitudinal fiber direction. The difference in tensile and compressive strengths at these low angles is attributable to different failure modes in tension and compression for this particular composite material. Failure in tension is characterized by fiber fracture while failure in compression is characterized by fiber micro-buckling. This result would not be the case for all composite materials and certainly would not be expected for isotropic materials. The difference in tensile and compressive strengths at large angles of  $\theta$  is again attributable to differences in tensile and compressive failure modes in the transverse (T) direction. Relatively low tensile strength in the transverse direction of a lamina (ply) is typical as the matrix material fractures with multiple cracks forming parallel to the fiber reinforcement. This effect is minimized in composite structures by stacking plies at varying angles to achieve quasi-isotropic behavior.

### 6.1.2 Maximum Strain Theory

This failure criterion states that failure occurs when strains in any of the natural (material) axes exceeds the corresponding allowable strain. Thus the following inequalities must be satisfied to avoid failure

$$\begin{aligned}\varepsilon_L &< \varepsilon_{LU} \\ \varepsilon_T &< \varepsilon_{TU} \\ \gamma_{LT} &< \gamma_{LTU}\end{aligned}\quad (6.6)$$

If the normal strains are compressive, then  $\varepsilon_{LU}$  and  $\varepsilon_{TU}$  are replaced by the allowable compressive strains as below

$$\begin{aligned}\varepsilon_L &< \varepsilon'_{LU} \\ \varepsilon_T &< \varepsilon'_{TU}\end{aligned}\quad (6.7)$$

Again consider an orthotropic lamina subjected to a stress  $\sigma_x$  making an angle  $\theta$  with the longitudinal fiber direction (see Figure 6.1). Substituting values for the stresses in material coordinates into the compliance equations (3.19) yields the following.

$$\begin{Bmatrix} \varepsilon_L \\ \varepsilon_T \\ \gamma_{LT} \end{Bmatrix} = \begin{bmatrix} \frac{1}{E_L} & \frac{-\gamma_{TL}}{E_T} & 0 \\ -\frac{\gamma_{LT}}{E_L} & \frac{1}{E_T} & 0 \\ 0 & 0 & \frac{1}{G_{LT}} \end{bmatrix} \begin{Bmatrix} \sigma_x \cos^2 \theta \\ \sigma_x \sin^2 \theta \\ -\sigma_x \sin \theta \cos \theta \end{Bmatrix} \quad (6.8)$$

Carrying out the matrix multiplication and combining with the maximum strain criteria gives the following inequalities.

$$\begin{aligned} \frac{\sigma_X}{\sigma_{LU}} &< \frac{E_L \varepsilon_{LU}}{\sigma_{LU}} \frac{1}{(\cos^2 \theta - \nu_{LT} \sin^2 \theta)} \\ \frac{\sigma_X}{\sigma_{LU}} &< \frac{E_T \varepsilon_{TU}}{\sigma_{LU}} \frac{1}{(\sin^2 \theta - \nu_{LT} \cos^2 \theta)} \\ \frac{\sigma_X}{\sigma_{LU}} &< \frac{G_{LT} \gamma_{LTU}}{\sigma_{LU}} \frac{1}{\sin \theta \cos \theta} \end{aligned} \quad (6.9)$$

If we assume that the material behavior is *linear elastic to failure*, these inequalities can be simplified by substituting

$$\begin{aligned} \sigma_{LU} &= E_L \varepsilon_{LU} \\ \sigma_{TU} &= E_T \varepsilon_{TU} \\ \tau_{LTU} &= G_{LT} \gamma_{LTU} \end{aligned} \quad (6.10)$$

Thus, in this example, the maximum strain criteria given in (6.9) reduces to

$$\begin{aligned} \frac{\sigma_X}{\sigma_{LU}} &< \frac{1}{(\cos^2 \theta - \nu_{LT} \sin^2 \theta)} \\ \frac{\sigma_X}{\sigma_{LU}} &< \frac{\sigma_{TU}}{\sigma_{LU}} \frac{1}{(\sin^2 \theta - \nu_{LT} \cos^2 \theta)} \\ \frac{\sigma_X}{\sigma_{LU}} &< \frac{\tau_{LTU}}{\sigma_{LU}} \frac{1}{\sin \theta \cos \theta} \end{aligned} \quad (6.11)$$

When the applied stress  $\sigma_X$  is compressive, the first of these two inequalities are modified by replacing the tensile strength values with their corresponding compressive strength values. The third inequality in (6.11) remains unchanged as it involves the limit on shear strain which is unaffected by whether or not the loading is tensile or compressive. The maximum strain criteria for compressive loads becomes

$$\frac{\sigma_X}{\sigma_{LU}} < \frac{\sigma'_{LU}}{\sigma_{LU}} \frac{1}{(\cos^2 \theta - \nu_{LT} \sin^2 \theta)}$$

$$\frac{\sigma_X}{\sigma_{LU}} < \frac{\sigma'_{TU}}{\sigma_{LU}} \frac{1}{(\sin^2 \theta - \nu_{LT} \cos^2 \theta)}$$
(6.12)

Comparing the maximum strain criteria to the maximum stress criteria, we see that the criteria look identical except for the Poisson's ratio terms. Therefore the differences in the failure predictions of these two theories are minimal. It should be noted, however, that *if the composite material does not behave linearly elastic to failure then the predictions can be quite different.*

Considering the same E-glass epoxy lamina, again for any particular value of  $\theta$ , the inequality giving the lowest value of strength is the appropriate failure prediction. The off-axis strength predictions using the maximum strain criteria are plotted below for values of  $\theta$  ranging from  $0^\circ$  to  $90^\circ$ . The strength results are again plotted in terms of normalized stress  $\sigma_X / \sigma_{LU}$ .

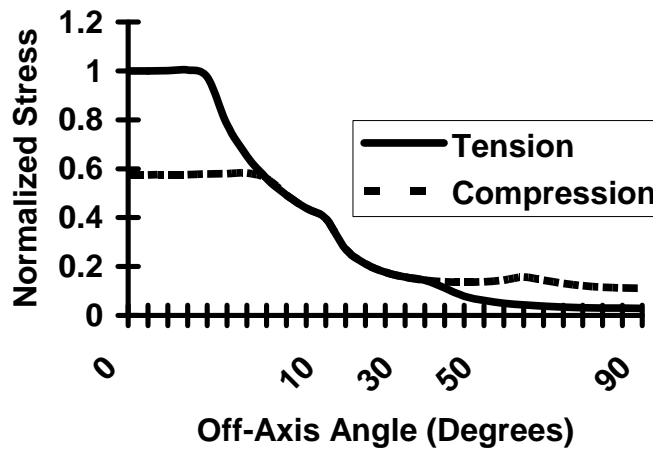

**Figure 6.3. Normalized Stress  $\sigma_X / \sigma_{LU}$  Related to Off-Axis Angle  $\theta$ , Maximum Strain Failure Theory**

The results in this case are virtually identical to those obtained using the maximum stress criteria.

### 6.1.3 Hashin Quadratic Theory

As a third example of a separable failure criteria, consider the quadratic strength theory as developed by Hashin [12]. In this criteria, there is coupling between extensional and shear modes of failure.

It is not uncommon in applying Hashin's failure theory to replace the transverse (out-of-plane) shear strength  $\tau_{TTU}$  with the in-plane shear strength value  $\tau_{LTU}$ . This assumption modifies Hashin's compressive matrix failure prediction. This is to some extent due to the difficulty in experimentally quantifying the transverse shear strength. Also there is some question as to the logic of including an out-of-plane strength term in a two dimensional plane stress formulation. In any event, there is a certain compensation of errors in replacing  $\tau_{TTU}$  with  $\tau_{LTU}$  in Hashin's 2-D formulation [11].

Hashin based his formulation on logical reasoning rather than micromechanics. This criteria has been successfully applied to progressive failure analysis of varying laminate ply lay-ups by using in-situ unidirectional strengths [13]. Use of in-situ strengths provides a method to account for the constraining interactions between plies.

The governing equations are listed below for a biaxial state of stress.

*Fiber Mode (Tension)*

$$\left(\frac{\sigma_L}{\sigma_{LU}}\right)^2 + \left(\frac{\tau_{LT}}{\tau_{LTU}}\right)^2 < 1 \quad (6.13)$$

*Fiber Mode (Compression)*

$$\sigma_L < \sigma'_{LU} \quad (6.14) \text{ (same as maximum stress criteria)}$$

*Matrix Mode (Tension)*

$$\left(\frac{\sigma_T}{\sigma_{TU}}\right)^2 + \left(\frac{\tau_{LT}}{\tau_{LTU}}\right)^2 < 1 \quad (6.15)$$

*Matrix Mode (Compression)*

$$\left(\frac{\sigma_T}{2\tau_{TTU}}\right)^2 + \left[\left(\frac{\sigma'_{TU}}{2\tau_{TTU}}\right)^2 - 1\right] \frac{\sigma_T}{\sigma'_{TU}} + \left(\frac{\tau_{LT}}{\tau_{LTU}}\right)^2 < 1 \quad (6.16)$$

Again consider an orthotropic lamina subjected to a stress  $\sigma_x$  making an angle  $\theta$  with the longitudinal fiber direction (see Figure 6.1). Assuming that  $\tau_{TTU} = \tau_{LTU}$  and using the same E-glass epoxy properties, the inequality giving the lowest value of strength is the appropriate failure prediction.

Substituting stresses in material ( $LT$ ) coordinates from (6.3) into (6.13) gives

$$\frac{\sigma_X^2}{\sigma_{LU}^2} \cos^4 \theta + \frac{\sigma_X^2}{\sigma_{LU}^2} \frac{\sigma_{LU}^2}{\tau_{LTU}^2} \sin^2 \theta \cos^2 \theta = 1 \quad (6.17)$$

Rearranging yields the normalized stress for the *tensile fiber failure mode* as

$$\frac{\sigma_X}{\sigma_{LU}} = \frac{1}{\sqrt{\cos^4 \theta + \frac{\sigma_{LU}^2}{\tau_{LTU}^2} \sin^2 \theta \cos^2 \theta}} \quad (6.18)$$

For the *compressive fiber failure mode*, we have the equivalent of the maximum stress criteria. This constraint is written as

$$\frac{\sigma_X}{\sigma_{LU}} = \frac{1}{\cos^2 \theta} \frac{\sigma'_{LU}}{\sigma_{LU}} \quad (6.19)$$

Substituting the stresses into (6.15) gives the criteria for *tensile matrix failure* as

$$\frac{\sigma_X^2}{\sigma_{LU}^2} \frac{\sigma_{LU}^2}{\sigma_{TU}^2} \sin^4 \theta + \frac{\sigma_X^2}{\sigma_{LU}^2} \frac{\sigma_{LU}^2}{\tau_{LTU}^2} \sin^2 \theta \cos^2 \theta = 1 \quad (6.20)$$

Solving for the normalized stress gives

$$\frac{\sigma_X}{\sigma_{LU}} = \frac{1}{\sqrt{\frac{\sigma_{LU}^2}{\sigma_{TU}^2} \sin^4 \theta + \frac{\sigma_{LU}^2}{\tau_{LTU}^2} \sin^2 \theta \cos^2 \theta}} \quad (6.21)$$

Finally, for the *compressive matrix failure mode* in this example we have from (6.16)

$$\frac{\sigma_X^2}{\sigma_{LU}^2} \left[ \frac{\sigma_{LU}^2}{4\tau_{LTU}^2} \sin^4 \theta + \frac{\sigma_{LU}^2}{\tau_{LTU}^2} \sin^2 \theta \cos^2 \theta \right] + \frac{\sigma_X}{\sigma_{LU}} \left( \frac{\sigma_{TU}'^2}{4\tau_{LTU}^2} - 1 \right) \frac{\sigma_{LU}}{\sigma_{TU}'} \sin^2 \theta - 1 = 0 \quad (6.22)$$

As can be seen, (6.22) is a quadratic equation which can be solved for  $\sigma_X/\sigma_{LU}$ . Again note that the inequality giving the lowest value of strength is the appropriate failure prediction. Results are plotted below for the E-glass epoxy lamina. The Hashin quadratic criteria is compared to results previously obtained using the maximum stress criteria. It can be observed that the failure predictions are in close agreement for applied compressive stresses, however the maximum stress theory over predicts strength in this example when the applied stresses are tensile in nature.

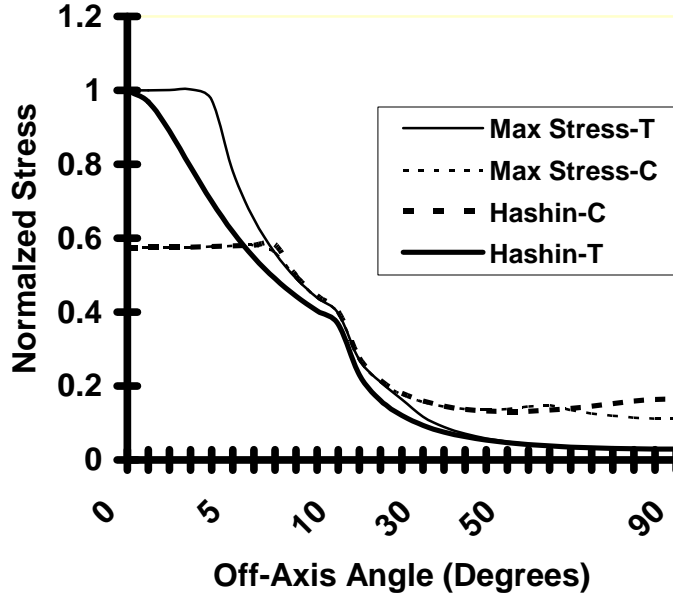

**Figure 6.4. Normalized Stress  $\sigma_x / \sigma_{LU}$  Related to Off-Axis Angle  $\theta$ , Hashin Quadratic vs. Maximum Stress Failure Theories**

There is evidence that when a composite is subjected to a combined  $\sigma_T, \tau_{LT}$  loading, it becomes stronger when  $\sigma_T$  is compressive. This implies that the in-plane shear stress  $\tau_{LT}$  at failure corresponding to  $\sigma_T = -\sigma_o$  is appreciably greater than the shear stress  $\tau_{LT}$  at failure corresponding to  $\sigma_T = +\sigma_o$  [14]. Sun et al. [15] proposed an empirical modification to the failure criteria proposed by Hashin in 1973 [16] for *matrix compression failure* to account for the beneficial role that compressive  $\sigma_T$  has on matrix shear strength. This modification is written as:

*Matrix Mode (Compression)*

$$\left( \frac{\sigma_T}{\sigma'_{TU}} \right)^2 + \left( \frac{\tau_{LT}}{\tau_{LTU} - \eta \sigma_T} \right)^2 < 1 \quad (6.23)$$

In this expression,  $\eta$  is an experimentally determined constant and can be thought of as an internal material friction parameter. The denominator in the shear stress term is effectively an in-plane shear strength term that increases with the transverse compressive stress  $\sigma_T$ . This modification to Hashin's criteria for compressive matrix failure is not pursued further here due to the added complexity required to experimentally determine

the friction parameter  $\eta$ . For additional insight into this particular modification to Hashin's criteria and into other alternative criteria requiring more extensive experimentation see [11,13,14].

#### 6.1.4 Chang Quadratic Theory

As a fourth and final example of a separable failure criteria, consider the quadratic theory as developed by Chang et al. [17-18]. Actually the Chang criteria presented here evolves from the references cited and is the version used in the finite element based computer code MSC Dytran, see [11]. This criteria is a modification to Hashin's criteria and therefore couples the extensional and shear modes of failure. The governing equations are listed below for the biaxial state of plane stress.

*Fiber Mode (Tension)*

$$\left( \frac{\sigma_L}{\sigma_{LU}} \right)^2 + T < 1 \quad (6.24)$$

*Matrix Mode (Tension)*

$$\left( \frac{\sigma_T}{\sigma_{TU}} \right)^2 + T < 1 \quad (6.25)$$

*Matrix Mode (Compression)*

$$\left( \frac{\sigma_T}{2\tau_{LTU}} \right)^2 + \left[ \left( \frac{\sigma'_{TU}}{2\tau_{LTU}} \right)^2 - 1 \right] \frac{\sigma_T}{\sigma'_{TU}} + T < 1 \quad (6.26)$$

In these expressions, the quantity  $T$  takes the form

$$T = \left( \frac{\tau_{LT}}{\tau_{LTU}} \right)^2 \left( \frac{1 + \frac{3}{2} \alpha G_{LT} \tau_{LT}^2}{1 + \frac{3}{2} \alpha G_{LT} \tau_{LTU}^2} \right) \quad (6.27)$$

Here  $\alpha$  is an experimentally defined coefficient used to represent the nonlinear in-plane shear strain-stress behavior as represented below.

$$\gamma_{LT} = \frac{\tau_{LT}}{G_{LT}} + \alpha \tau_{LT}^3 \quad (6.28)$$

Observe that for  $\alpha = 0$  these failure criteria reduce to Hashin's criteria except that the in-plane shear strength  $\tau_{LTU}$  replaces the transverse (out-of-plane) shear strength  $\tau_{TTU}$ . Furthermore, for shear dominated failures where  $\tau_{LT}$  is the dominant stress and  $\tau_{LT} \rightarrow \tau_{LTU}$  the Chang criteria again reduces to the Hashin criteria.

As before consider an orthotropic lamina subjected to a stress  $\sigma_x$  making an angle  $\theta$  with the longitudinal fiber direction (see Figure 6.1). Using the same E-glass epoxy properties, the inequality giving the lowest value of strength provides the appropriate failure prediction.

Substituting stresses in material ( $LT$ ) coordinates from (6.3) into (6.24) gives

$$\frac{\sigma_x^2}{\sigma_{LU}^2} \cos^4 \theta + \left( \frac{\sigma_x^2}{\sigma_{LU}^2} \frac{\sigma_{LU}^2}{\tau_{LTU}^2} \sin^2 \theta \cos^2 \theta \right) T(\theta) = 1 \quad (6.29)$$

For  $T(\theta)$  we have the following.

$$T(\theta) = \frac{1 + \frac{3}{2} \alpha G_{LT} \frac{\sigma_x^2}{\sigma_{LU}^2} \sin^2 \theta \cos^2 \theta}{1 + \frac{3}{2} \alpha G_{LT} \tau_{LTU}^2} \quad (6.30)$$

Rearranging (6.29) yields the normalized stress for the *tensile fiber failure mode* as

$$\frac{\sigma_x}{\sigma_{LU}} = \frac{1}{\sqrt{\cos^4 \theta + \left( \frac{\sigma_{LU}^2}{\tau_{LTU}^2} \sin^2 \theta \cos^2 \theta \right) T(\theta)}} \quad (6.31)$$

Substituting the stresses into (6.25) gives the criteria for *tensile matrix failure* as

$$\frac{\sigma_x^2}{\sigma_{LU}^2} \frac{\sigma_{LU}^2}{\sigma_{TU}^2} \sin^4 \theta + \left( \frac{\sigma_x^2}{\sigma_{LU}^2} \frac{\sigma_{LU}^2}{\tau_{LTU}^2} \sin^2 \theta \cos^2 \theta \right) T(\theta) = 1 \quad (6.32)$$

and solving for the normalized stress gives

$$\frac{\sigma_x}{\sigma_{LU}} = \frac{1}{\sqrt{\frac{\sigma_{LU}^2}{\sigma_{TU}^2} \sin^4 \theta + \left( \frac{\sigma_{LU}^2}{\tau_{LTU}^2} \sin^2 \theta \cos^2 \theta \right) T(\theta)}} \quad (6.33)$$

Finally, for the *compressive matrix failure mode* in this example we have from (6.26)

$$\frac{\sigma_X^2}{\sigma_{LU}^2} \frac{\sigma_{LU}^2}{4\tau_{LTU}^2} \sin^4 \theta + \frac{\sigma_X}{\sigma_{LU}} \left( \frac{\sigma_{TU}'^2}{4\tau_{LTU}^2} - 1 \right) \frac{\sigma_{LU}}{\sigma_{TU}'} \sin^2 \theta + T(\theta) - 1 = 0 \quad (6.34)$$

Clearly (6.34) is a quadratic equation which can be solved for  $\sigma_X / \sigma_{LU}$ . Again note that the inequality giving the lowest value of strength is the appropriate failure prediction.

Results are plotted below for the Chang quadratic criteria and are compared to the results previously obtained using the Hashin criteria. The coefficient  $\alpha$  is based on a least squares fit to experimental data obtained for E-glass epoxy [7]. *Note that compressive fiber failure is not considered by the Chang failure criteria.* Thus for small values of  $\theta$  (less than  $6^\circ$  in this example), the Chang criteria makes no valid prediction and the limiting failure curve for compressive loading is simply cut off for small values of  $\theta$ . In this particular example, the Chang and Hashin criteria are in close agreement. However, it should be noted that while all of the failure criteria under consideration can be implemented in a material nonlinear analysis, nonlinear material behavior is explicit in the Chang criteria due to the representation of shear behavior in (6.28). Thus the results obtained in this example with the Chang criteria are oversimplified because the results are based simply on a linear analysis using classical lamination theory.

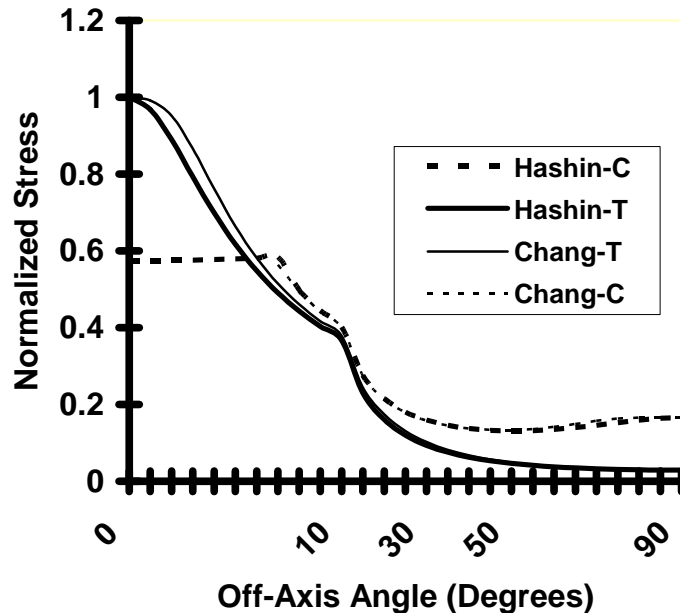

**Figure 6.5. Normalized Stress  $\sigma_X / \sigma_{LU}$  Related to Off-Axis Angle  $\theta$ , Hashin Quadratic vs. Chang Quadratic Failure Theories**

## 6.2 Generalized Strength (Failure) Theories

### 6.2.1 Tsai-Hill Theory

A failure theory for anisotropic materials was proposed by Hill [19]. The theory as proposed is actually a yield criteria but in the context of composite materials the yield strengths are treated as limits on linear elastic behavior. Therefore Hill's yield strengths are treated herein as failure strengths. Hill's yield criteria is an extension of the well known and much applied von Mises yield criteria for isotropic materials. The von Mises criteria is related to distortional strain energy and not to dilatation (change in volume). In the case of orthotropic materials distortional and dilatational effects can not be separated, thus this theory as applied to composite materials is not a distortional energy theory.

The failure strength parameters in Hill's theory were first related to the failure strengths of an orthotropic lamina by Tsai [20]. Thus this failure theory for orthotropic lamina is referred to as the Tsai-Hill theory. It is also referred to as the maximum work theory. Experimental support for this theory has been demonstrated by several authors, e.g., [21].

Hill's criteria for yielding of anisotropic materials has the form

$$\begin{aligned} (G + H)\sigma_L^2 + (F + H)\sigma_T^2 + (F + G)\sigma_{T'}^2 - 2H\sigma_L\sigma_T - 2G\sigma_L\sigma_{T'} - 2F\sigma_T\sigma_{T'} \\ + 2L\tau_{TT'}^2 + 2M\tau_{LT'}^2 + 2N\tau_{LT}^2 < 1 \end{aligned} \quad (6.35)$$

The failure strength parameters can be related to the usual failure strengths by considering the separate application of simple stress states. Consider first that  $\tau_{LT}$  acts alone. Based on the criteria in (6.35) this gives

$$2N = \frac{1}{\tau_{LTU}^2} \quad (6.36)$$

If  $\sigma_L$  acts alone we have

$$G + H = \frac{1}{\sigma_{LU}^2}$$

When  $\sigma_T$  acts alone, criteria (6.35) gives

$$F + H = \frac{1}{\sigma_{TU}^2}$$

and if  $\sigma_{T'}$  acts alone

$$F + G = \frac{1}{\sigma_{T'U}^2}$$

Combining the above three equations provides definition of three strength parameters. These parameters are given as

$$\begin{aligned} 2H &= \frac{1}{\sigma_{LU}^2} + \frac{1}{\sigma_{TU}^2} - \frac{1}{\sigma_{T'U}^2} \\ 2G &= \frac{1}{\sigma_{LU}^2} + \frac{1}{\sigma_{T'U}^2} - \frac{1}{\sigma_{TU}^2} \\ 2F &= \frac{1}{\sigma_{TU}^2} + \frac{1}{\sigma_{T'U}^2} - \frac{1}{\sigma_{LU}^2} \end{aligned} \quad (6.37)$$

For the biaxial (plane) stress state of interest we can assume that the *through-the-thickness* of the lamina stresses are essentially zero. This gives

$$\sigma_{T'} = \tau_{LT'} = \tau_{TT'} = 0 \quad (6.38)$$

If we consider the cross section of a typical lamina (ply) as depicted in the sketch below

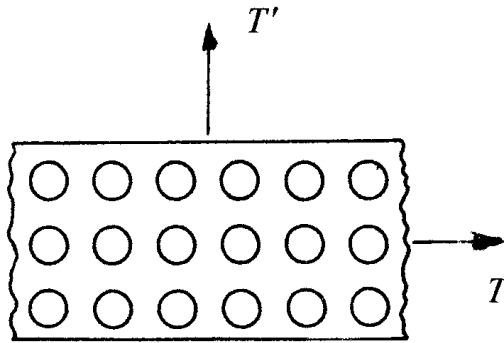

**Figure 6.6. Cross Section of Unidirectional Lamina With Fibers in L Direction**

and simply consider the geometrical symmetry, it is concluded that

$$\sigma_{T'U} = \sigma_{TU} \quad (6.39)$$

Substituting (6.38) and (6.39) into (6.37) gives

$$2H = 2G = \frac{1}{\sigma_{LU}^2} \quad (6.40)$$

$$2F = \frac{2}{\sigma_{TU}^2} - \frac{1}{\sigma_{LU}^2}$$

Rearranging the strength parameters in (6.40) yields

$$G + H = \frac{1}{\sigma_{LU}^2} \quad (6.41)$$

and

$$F + H = \frac{1}{\sigma_{TU}^2} \quad (6.42)$$

Substituting the strength parameters into (6.35) gives the Tsai-Hill failure theory for the case of biaxial (plane) stress. Failure is initiated when the inequality below is violated.

$$\left( \frac{\sigma_L}{\sigma_{LU}} \right)^2 - \frac{\sigma_L \sigma_T}{\sigma_{LU}^2} + \left( \frac{\sigma_T}{\sigma_{TU}} \right)^2 + \left( \frac{\tau_{LT}}{\tau_{LTU}} \right)^2 < 1 \quad (6.43)$$

When normal stresses are compressive, the tensile strengths are replaced with compressive strengths. It is interesting to see that the Tsai-Hill theory reduces to the von Mises theory for isotropic materials by making the following substitutions

$$\begin{aligned} \sigma_L &= \sigma_1 \\ \sigma_T &= \sigma_2 \\ \tau_{LT} &= 0 \\ \sigma_{LU} &= \sigma_{TU} = \sigma_Y \end{aligned} \quad (6.44)$$

where  $\sigma_1$  and  $\sigma_2$  are the principal stresses for the isotropic material and  $\sigma_Y$  the yield strength. For an isotropic material, (6.43) then reduces to the von Mises yield criteria as below

$$\sigma_1^2 - \sigma_1 \sigma_2 + \sigma_2^2 < \sigma_Y^2 \quad (6.45)$$

The Tsai-Hill failure theory given in (6.43) provides a single function to predict strength.

Again consider the same example of an E-glass epoxy (angled ply) lamina with stress  $\sigma_x$  applied (see Figure 6.1). Substituting the stresses in natural (material) coordinates into (6.43) in this example yields the following for the case of tensile loading

$$\cos^4 \theta + \left( \frac{\sigma_{LU}^2}{\tau_{LTU}^2} - 1 \right) \cos^2 \theta \sin^2 \theta + \frac{\sigma_{LU}^2}{\sigma_{TU}^2} \sin^4 \theta < \frac{\sigma_{LU}^2}{\sigma_X^2} \quad (6.46)$$

A similar expression is obtained for the case of compressive loading

$$\left( \frac{\sigma_{LU}}{\sigma'_{LU}} \right)^2 \cos^4 \theta + \left( \frac{\sigma_{LU}^2}{\tau_{LTU}^2} - \frac{\sigma_{LU}^2}{\sigma'_{LU}{}^2} \right) \cos^2 \theta \sin^2 \theta + \frac{\sigma_{LU}^2}{\sigma'_{TU}{}^2} \sin^4 \theta < \frac{\sigma_{LU}^2}{\sigma_X^2} \quad (6.47)$$

For plotting purposes, these equations can be written in the general form

$$\frac{\sigma_X}{\sigma_{LU}} < f(\sigma_{LU}, \sigma_{TU}, \tau_{LTU}, \sigma'_{LU}, \sigma'_{TU}) \quad (6.48)$$

The off-axis strength predictions using the Tsai-Hill criteria are compared to the maximum stress criteria for values of  $\theta$  ranging from  $0^\circ$  to  $90^\circ$ . The strength results are again plotted in terms of normalized stress  $\sigma_X / \sigma_{LU}$ .

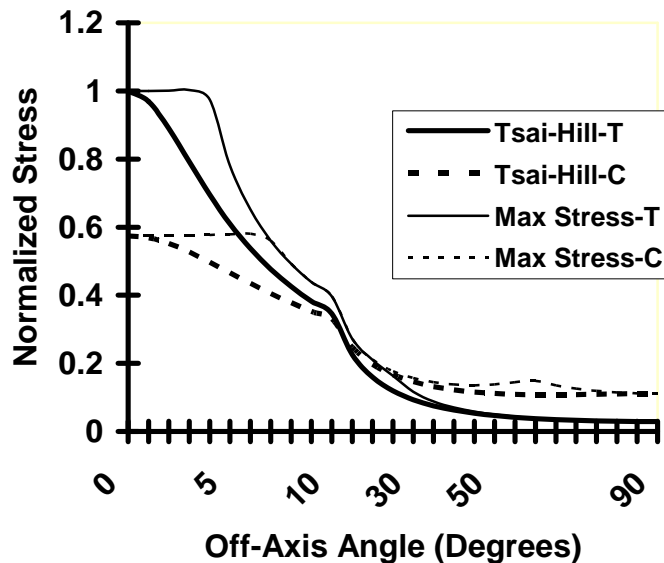
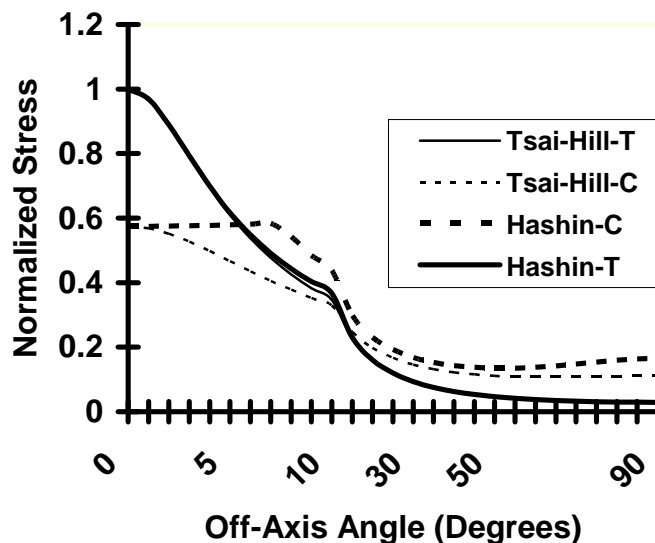

**Figure 6.7. Normalized Stress  $\sigma_X / \sigma_{LU}$  Related to Off-Axis Angle  $\theta$ , Tsai-Hill vs. Max. Stress Failure Theories**

The Tsai-Hill theory predicts lower strengths than those predicted by the maximum stress theory and has been shown to be in better agreement with experimental data than those results obtained using either the maximum stress or maximum strain theory [9]. One reason for the better agreement with experiments is the fact that there is considerable

interaction between the failure strengths  $(\sigma_{LU}, \sigma_{TU}, \tau_{LTU})$  in the Tsai-Hill criteria. This interaction does not exist for either the maximum stress or maximum strain criteria, i.e., in the latter two theories, axial, transverse and shear failures are assumed to occur independently.

In this example of applying  $\sigma_x$  to an angle ply with  $\theta$  ranging from  $0^\circ$  to  $90^\circ$ , the Tsai-Hill and Hashin quadratic strength theories are in close agreement when the applied stress state is tensile, as shown in Figure 6.8 below. This is primarily because these strength theories each exhibit coupling between axial and shear deformation under a tensile stress state. For a compressive stress state, the Hashin criteria is more similar to the maximum stress criteria, particularly for low values of  $\theta$ .



**Figure 6.8. Normalized Stress  $\sigma_x / \sigma_{LU}$  Related to Off-Axis Angle  $\theta$ , Tsai-Hill vs. Hashin Quadratic Failure Theories**

### 6.2.2 Tsai-Wu Tensor Theory

A way to theoretically improve the correlation between theory and experiment for strength theories is to increase the number of terms, particularly with respect to terms relating to the interaction between stresses in two directions. Tsai and Wu [22] accomplished this objective in their tensor strength theory for composites. They postulated a failure surface in stress space of the form

$$F_i \sigma_i + F_{ij} \sigma_i \sigma_j = 1; \quad i, j = 1, 6 \quad (6.49)$$

wherein  $F_i$  and  $F_{ij}$  are strength tensors of the second and fourth rank. The usual contracted stress notation is used, i.e.,  $\sigma_4 = \tau_{TT'}$ ,  $\sigma_5 = \tau_{T'L}$  and  $\sigma_6 = \tau_{LT}$ . For the case of an orthotropic lamina under plane stress conditions, (6.49) reduces to the form

$$F_1\sigma_L + F_2\sigma_T + F_6\tau_{LT} + F_{11}\sigma_L^2 + F_{22}\sigma_T^2 + F_{66}\tau_{LT}^2 + 2F_{12}\sigma_L\sigma_T = 1 \quad (6.50)$$

The linear strength constants serve to represent different strengths in tension and compression. Quadratic strength constants provide the representation of an ellipsoid in stress space. The  $F_{12}$  term is the basis for representing the interaction between the normal stresses in material coordinates. The ability to represent the interaction between  $\sigma_L$  and  $\sigma_T$  provides more generality than achieved with the Tsai-Hill theory. Of course, more experimental data is required in that some tests are needed with the application of either biaxial stresses or an off-axis uniaxial stress.

All of the strength constants in equation (6.50), except for the interaction term  $F_{12}$ , can be defined on the basis of simple uniaxial or pure shear testing. Note that all of the strength quantities, including  $\sigma'_{LU}$  and  $\sigma'_{TU}$ , are treated as positive quantities in the following equations.

First consider the case where the only nonzero stress is  $\sigma_L \neq 0$ . Loading the uniaxial specimen to failure gives

$$F_1\sigma_{LU} + F_{11}\sigma_{LU}^2 = 1 \quad (\text{tension})$$

$$F_1\sigma'_{LU} + F_{11}\sigma_{LU}'^2 = 1 \quad (\text{compression})$$

Then solving for the strength constants yields

$$F_1 = \frac{1}{\sigma_{LU}} - \frac{1}{\sigma_{LU}'^2} \quad (6.51)$$

$$F_{11} = \frac{1}{\sigma_{LU}\sigma_{LU}'^2}$$

Similarly, applying the only nonzero stress  $\sigma_T$  to a uniaxial test specimen until failure gives

$$F_2\sigma_{TU} + F_{22}\sigma_{TU}^2 = 1 \quad (\text{tension})$$

$$F_2\sigma'_{TU} + F_{22}\sigma_{TU}'^2 = 1 \quad (\text{compression})$$

Solving for the strength constants

$$F_2 = \frac{1}{\sigma_{TU}} - \frac{1}{\sigma'_{TU}} \quad (6.52)$$

$$F_{22} = \frac{1}{\sigma_{TU}\sigma'_{TU}}$$

Applying pure shear  $\tau_{LT}$  in material coordinates gives the following

$$F_6 = 0 \quad (\text{because sign of shear not important in LT coordinates})$$

$$F_{66}\tau_{LTU}^2 = 1$$

or

$$F_{66} = \frac{1}{\tau_{LTU}^2} \quad (6.53)$$

The remaining interactive term  $F_{12}$  can be determined based on the performance of biaxial stress tests. For example, consider the biaxial stress state  $\sigma_L = \sigma_T = \sigma$  and other stresses zero. Here,  $\sigma$  is the biaxial stress required to produce failure in the specimen. Substituting into (6.50) gives

$$(F_1 + F_2)\sigma + (F_{11} + F_{22} + 2F_{12})\sigma^2 = 1$$

Solving this equation for the interactive term gives

$$F_{12} = \frac{1}{2\sigma^2}(1 - C_1\sigma - C_2\sigma^2) \quad (6.54)$$

where

$$C_1 = \frac{1}{\sigma_{LU}} - \frac{1}{\sigma'_{LU}} + \frac{1}{\sigma_{TU}} - \frac{1}{\sigma'_{TU}}$$

and

$$C_2 = \frac{1}{\sigma_{LU}\sigma'_{LU}} + \frac{1}{\sigma_{TU}\sigma'_{TU}}$$

Thus the interactive  $F_{12}$  term depends on the engineering strengths in the L and T directions as well as on the biaxial tensile failure strength  $\sigma$ . Note that off-axis uniaxial tests could be used as an alternative to determining the interactive  $F_{12}$  term.

Due to a finiteness constraint imposed on the stress state, the strength constants in the Tsai-Wu governing equation (6.50) for a two dimensional stress state can be shown to satisfy the following inequality

$$-\sqrt{F_{11}F_{22}} < F_{12} < \sqrt{F_{11}F_{22}} \quad (6.55)$$

In practice, this inequality can be used to estimate a value for  $F_{12}$  in lieu of performing biaxial or off-axis tests.

The Tsai-Wu theory is obviously more general than the Tsai-Hill theory in that the interactive term involves biaxial stress test results. Pipes and Cole obtained excellent agreement between the Tsai-Wu tensor theory and experimental data for boron/epoxy specimens, see [23]. In their tests, the Tsai-Wu and Tsai-Hill predicted strengths were in close agreement.

As one approach in theoretically specifying the interactive strength term  $F_{12}$ , consider normalizing the governing Tsai-Wu equation (6.50) in the following manner. Define normalized stress and strength terms as below

$$\begin{aligned} \sigma_L^* &= \sqrt{F_{11}} \sigma_L \\ \sigma_T^* &= \sqrt{F_{22}} \sigma_T \\ \tau_{LT}^* &= \sqrt{F_{66}} \tau_{LT} \\ F_1^* &= \frac{F_1}{\sqrt{F_{11}}} \\ F_2^* &= \frac{F_2}{\sqrt{F_{22}}} \\ F_{12}^* &= \frac{F_{12}}{\sqrt{F_{11}F_{22}}} = -\frac{1}{2} \end{aligned} \quad (6.56)$$

Substituting these forms into (6.50) yields a particular normalized form of the governing Tsai-Wu strength criteria as given here

$$\sigma_L^{*2} - \sigma_L^* \sigma_T^* + \sigma_T^{*2} + \tau_{LT}^{*2} + F_1^* \sigma_L^* + F_2^* \sigma_T^* = 1 \quad (6.57)$$

Here the linear terms determine the center of the ellipsoidal failure surface. For the case of zero shear ( $\tau_{LT} = 0$ ) equation (6.57) is a generalization of the von Mises criteria. The von Mises criteria can be written as

$$\sigma_L^{*2} - \sigma_L^* \sigma_T^* + \sigma_T^{*2} = 1 \quad (6.58)$$

This is an approach that has been suggested by Tsai and Hahn [25] to theoretically define the interactive strength term  $F_{12}$  as an alternative to biaxial or off-axis strength testing.

In order to again consider the E-glass epoxy (angled ply) lamina with stress  $\sigma_x$  applied (see Figure 6.1), consider writing the Tsai-Wu criteria in the following normalized form.

$$\begin{aligned} & \left(1 - \frac{\sigma_{LU}}{\sigma_{LU'}}\right) \frac{\sigma_L}{\sigma_{LU}} + \left(1 - \frac{\sigma_{TU}}{\sigma_{TU'}}\right) \frac{\sigma_T}{\sigma_{TU}} + \frac{\sigma_{LU}}{\sigma_{LU'}} \frac{\sigma_L^2}{\sigma_{LU}^2} + \frac{\sigma_{TU}}{\sigma_{TU'}} \frac{\sigma_T^2}{\sigma_{TU}^2} + \frac{\tau_{LT}^2}{\tau_{LTU}^2} \\ & + 2\sigma_{LU}\sigma_{TU}F_{12} \frac{\sigma_L}{\sigma_{LU}} \frac{\sigma_T}{\sigma_{TU}} = 1 \end{aligned} \quad (6.59)$$

The applied stress  $\sigma_x$  is transformed to material coordinates as given in equation (6.3). Substituting these stresses into (6.59) and using the theoretical assumption for the interactive strength term  $F_{12}$  from (6.56) gives

$$\begin{aligned} & \left(1 - \frac{\sigma_{LU}}{\sigma_{LU'}}\right) \frac{\sigma_x}{\sigma_{LU}} \cos^2 \theta + \left(1 - \frac{\sigma_{TU}}{\sigma_{TU'}}\right) \left(\frac{\sigma_{LU}}{\sigma_{TU}}\right) \frac{\sigma_x}{\sigma_{LU}} \sin^2 \theta + \frac{\sigma_{LU}}{\sigma_{LU'}} \frac{\sigma_x^2}{\sigma_{LU}^2} \cos^4 \theta \\ & + \frac{\sigma_{TU}}{\sigma_{TU'}} \left(\frac{\sigma_{LU}^2}{\sigma_{TU}^2}\right) \frac{\sigma_x^2}{\sigma_{LU}^2} \sin^4 \theta + \left(\frac{\sigma_{LU}^2}{\tau_{LTU}^2}\right) \frac{\sigma_x^2}{\sigma_{LU}^2} \sin^2 \theta \cos^2 \theta \\ & - \frac{\sigma_{LU}}{\sigma_{TU}} \sqrt{\frac{\sigma_{LU}}{\sigma_{LU'}} \frac{\sigma_{TU}}{\sigma_{TU'}}} \frac{\sigma_x^2}{\sigma_{LU}^2} \sin^2 \theta \cos^2 \theta = 1 \end{aligned} \quad (6.60)$$

This is a quadratic equation which can be solved for  $\frac{\sigma_x}{\sigma_{LU}}$  as a function of  $\theta$ . Writing the quadratic equation in the form

$$A \frac{\sigma_x^2}{\sigma_{LU}^2} + B \frac{\sigma_x}{\sigma_{LU}} + C = 0 \quad (6.61)$$

The coefficients in this quadratic form can be defined as follows

$$A = \frac{\sigma_L}{\sigma_{LU'}} \cos^4 \theta + \frac{\sigma_{TU}}{\sigma_{TU'}} \frac{\sigma_{LU}^2}{\sigma_{TU}^2} \sin^4 \theta + \left( \frac{\sigma_{LU}^2}{\tau_{LTU}^2} - \frac{\sigma_{LU}}{\sigma_{TU}} \sqrt{\frac{\sigma_{LU}}{\sigma_{LU'}} \frac{\sigma_{TU}}{\sigma_{TU'}}} \right) \sin^2 \theta \cos^2 \theta \quad (6.50)$$

$$B = \left( 1 - \frac{\sigma_{LU}}{\sigma_{LU'}} \right) \cos^2 \theta + \left( 1 - \frac{\sigma_{TU}}{\sigma_{TU'}} \right) \frac{\sigma_{LU}}{\sigma_{TU}} \sin^2 \theta \quad (6.51)$$

$$C = -1 \quad (6.52)$$

The off-axis strength predictions using the Tsai-Wu criteria are compared to the Tsai-Hill criteria for values of  $\theta$  ranging from  $0^\circ$  to  $90^\circ$ . The strength results are again plotted in terms of normalized stress  $\sigma_x / \sigma_{LU}$ . These results are plotted for interactive strength term values ( $F_{12}^*$ ) of  $+1/2$  and  $-1/2$  in order to show the sensitivity of the results to variation in the interactive strength term. Note that  $F_{12}^* = -1/2$  is the theoretical assumption used in writing equation (6.48) above and is also the assumption suggested by Tsai and Hahn [24] in order to make the Tsai-Wu criteria look like a generalized form of the von Mises criteria. The off-axis results coming from the Tsai-Wu criteria are plotted vs. the Tsai-Hill criteria below for the case of applied tensile stress.

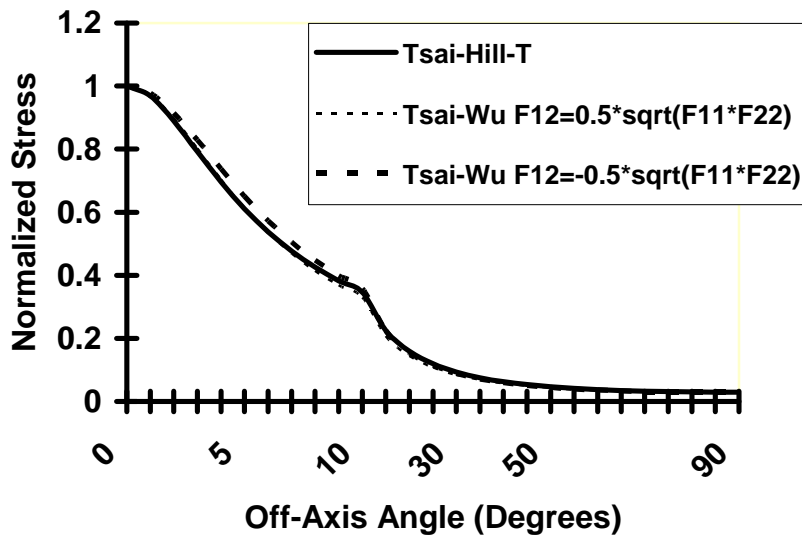
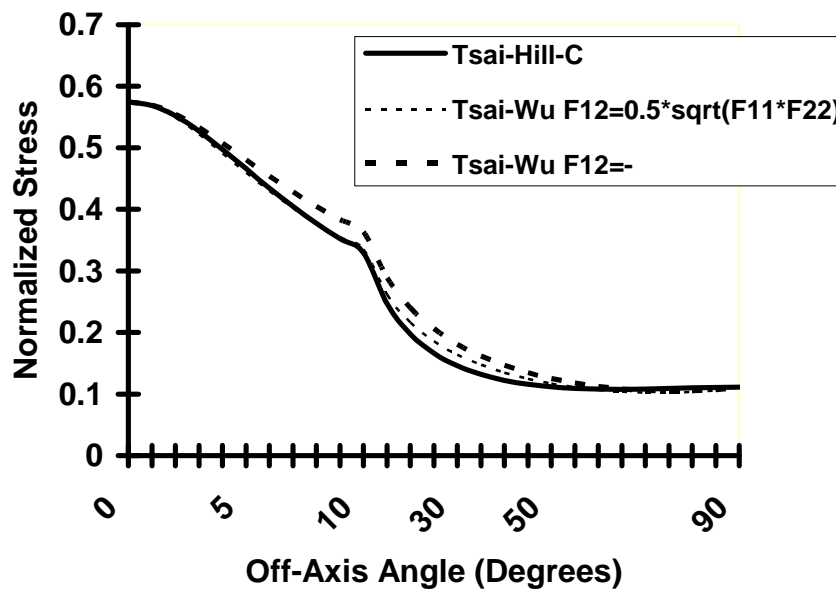

**Figure 6.9. Normalized Stress  $\sigma_x / \sigma_{LU}$  Related to Off-Axis Angle  $\theta$ , Tsai-Wu vs. Tsai-Hill Failure Theories (Tension)**

It is observed in Figure 6.9 that the predicted strength results for the applied tensile stress are not sensitive to variation in the interactive strength term. Furthermore, the strengths

predicted by the Tsai-Wu criteria are in excellent agreement with those predicted by the Tsai-Hill criteria for the full range of off-axis angle  $\theta$ .

When the applied stress is compressive, the strength results are somewhat more sensitive to variation in the interactive strength term ( $F_{12}^*$ ) as observed in Figure 6.10 below. Again the Tsai-Wu and Tsai-Hill results compare favorably, however, the Tsai-Wu criteria predicts higher strength values for a range of off-axis angles away from the  $0^\circ$  and  $90^\circ$  end points. Overall, for the particular case of applying a uniaxial tensile or compressive stress to an off-axis specimen the Tsai-Wu and Tsai-Hill failure criteria are in reasonably good agreement.



**Figure 6.10. Normalized Stress  $\sigma_x / \sigma_{LU}$  Related to Off-Axis Angle  $\theta$ , Tsai-Wu vs. Tsai-Hill Failure Theories (Compression)**

### 6.3 Another Example Comparing Failure Theories

As a further example of applying the various strength theories, consider again the biaxial state of stress used in the first example. The applied stress state is given as  $\sigma_x = 20$  MPa,  $\sigma_y = 40$  MPa, and  $\tau_{xy} = 0$ . The fiber reinforcement (L axis) is oriented at  $\theta = 60^\circ$  with respect to the reference X axis. The stresses in natural (material) coordinates were previously calculated as  $\sigma_L = 35$  MPa,  $\sigma_T = 25$  MPa, and  $\tau_{LT} = 8.66$  MPa. Assuming the E-glass epoxy properties as previously defined, the results for each of the strength criteria are given below.

*Max. Stress Criteria*

$$\frac{\sigma_L}{\sigma_{LU}} = 0.03296 < 1; \quad \frac{\sigma_T}{\sigma_{TU}} = 0.8062 < 1; \quad \frac{\tau_{LT}}{\tau_{LTU}} = 0.1203 < 1$$

*Max. Strain Criteria*

Substituting the compliance relation (3.19) into the maximum strain criteria (6.6) and assuming linear elastic behavior to failure gives

$$\varepsilon_L = \frac{\sigma_L}{E_L} - \frac{\nu_{LT}}{E_L} \sigma_T < \frac{\sigma_{LU}}{E_L}$$

normalizing gives

$$\frac{\sigma_L}{\sigma_{LU}} - \nu_{LT} \frac{\sigma_T}{\sigma_{LU}} < 1; \quad \text{or} \quad \frac{35}{1062} - 0.26 \left( \frac{25}{1062} \right) = 0.2684 < 1$$

$$\varepsilon_T = -\frac{\nu_{LT}}{E_L} \sigma_L + \frac{\sigma_T}{E_T} < \frac{\sigma_{TU}}{E_T}$$

again normalizing

$$-\nu_{TL} \frac{\sigma_L}{\sigma_{TU}} + \frac{\sigma_T}{\sigma_{TU}} < 1; \quad \text{or} \quad -.0557 \left( \frac{35}{31} \right) + \frac{25}{31} = 0.7436 < 1$$

$$\gamma_{LT} = \frac{\tau_{LT}}{G_{LT}} < \frac{\tau_{LTU}}{G_{LT}}$$

normalizing gives

$$\frac{\tau_{LT}}{\tau_{LTU}} = 0.1203 < 1 \quad (\text{same as for max. stress criteria in case of shear stress})$$

*Hashin Quadratic Criteria*

Substituting stresses and strengths into (6.13) and (6.15) respectively gives

$$\left( \frac{35}{1062} \right)^2 + \left( \frac{8.66}{72} \right)^2 = 0.1555 < 1 \quad \text{Fiber Mode (Tension)}$$

$$\left(\frac{25}{31}\right)^2 + \left(\frac{8.66}{72}\right)^2 = 0.6648 < 1 \quad \text{Matrix Mode (Tension)}$$

### *Chang Quadratic Criteria*

Substituting stresses and strengths into (6.24) and (6.25) gives

$$\left(\frac{35}{1062}\right)^2 + \left(\frac{8.66}{72}\right)^2 \mathbf{T} = 0.00442 \quad \text{Fiber Mode (Tension)}$$

$$\left(\frac{25}{31}\right)^2 + \left(\frac{8.66}{72}\right)^2 \mathbf{T} = 0.654 \quad \text{Matrix Mode (Tension)}$$

Here,  $\mathbf{T}$  as defined in (6.27) involves the experimental coefficient  $\alpha$ , see [7].

### *Tsai-Hill Criteria*

Substituting the stresses and strengths into (6.31) gives

$$\left(\frac{35}{1062}\right)^2 - \frac{35(25)}{1062^2} + \left(\frac{25}{31}\right)^2 + \left(\frac{8.66}{72}\right)^2 = 0.665 < 1$$

### *Tsai-Wu Criteria*

Substituting into (6.47) and assuming the strength interaction term  $F_{12}^* = -1/2$  gives

$$\begin{aligned} & (1-1.741)\frac{35}{1062} + (1-0.2627)\frac{25}{31} + \frac{1062}{610}\left(\frac{35}{1062}\right)^2 + \frac{31}{118}\left(\frac{25}{31}\right)^2 \\ & + 2(1062)(31)(-1.027 \times 10^{-5})\left(\frac{35}{1062}\right)\left(\frac{25}{31}\right) = 0.7395 < 1 \end{aligned}$$

In this particular example, the Hashin and Chang criteria make a strength prediction virtually identical to that of the Tsai-Hill criteria. Separable failure criteria like Hashin and Chang have the advantage over generalized criteria like Tsai-Hill or Tsai-Wu of being able to separate out the most likely mode of failure. The ability to separate out failure modes is particularly important when incorporating failure criteria into nonlinear damage models. Here the maximum stress criteria predicts the smallest margin of safety.

## **6.4 Failure Envelopes (Generalized Theories) for Biaxial Stress State**

In the case of isotropic materials, closed failure envelopes (surfaces) can be defined for the general case of biaxial stresses. These failure or yield envelopes are defined in terms

of principal stress coordinates. A good example is the von Mises yield surface as previously defined in equation (6.45), which is represented as an ellipse in principal stress space. It is not possible in the case of an orthotropic lamina to define such a general graphical representation for the biaxial stresses  $\sigma_L, \sigma_T$  and  $\tau_{LT}$  acting in the natural coordinate directions. This is because the principal stresses do not, in general, coincide with either a set of reference axes or the longitudinal and transverse directions. The principal stress directions align with the longitudinal and transverse directions only for the special case where  $\tau_{LT} = 0$ . Failure envelopes can be defined in terms of normalized stresses in natural coordinates, i.e.,  $\sigma_L / \sigma_{LU}$  and  $\sigma_T / \sigma_{TU}$  for a specified value of shear stress  $\tau_{LT}$ . As the shear stress is increased, the failure envelopes shrink resulting in reduced feasible design space.

Consider first the Tsai-Hill failure surface based on the E-glass properties used in previous examples. Because the Tsai-Hill strength criteria is adjusted to accommodate compressive stresses, the resulting closed failure surface is piecewise continuous in the normalized natural stress coordinate space. This failure surface is plotted below for the case of zero shear and the case of  $\tau_{LT} / \tau_{LTU} = 0.5$ . The intercepts on the compressive stress axes differ from those on the tensile stress axes because  $\sigma'_{LU} \neq \sigma_{LU}$  and  $\sigma'_{TU} \neq \sigma_{TU}$ . In the case of zero shear stress, these intercepts occur at  $\sigma_T / \sigma_{TU} = \sigma'_{TU} / \sigma_{TU} = 3.806$  and at  $\sigma_L / \sigma_{LU} = \sigma'_{LU} / \sigma_{LU} = 0.5744$ . Adding shear stress reduces the feasible design space as anticipated.

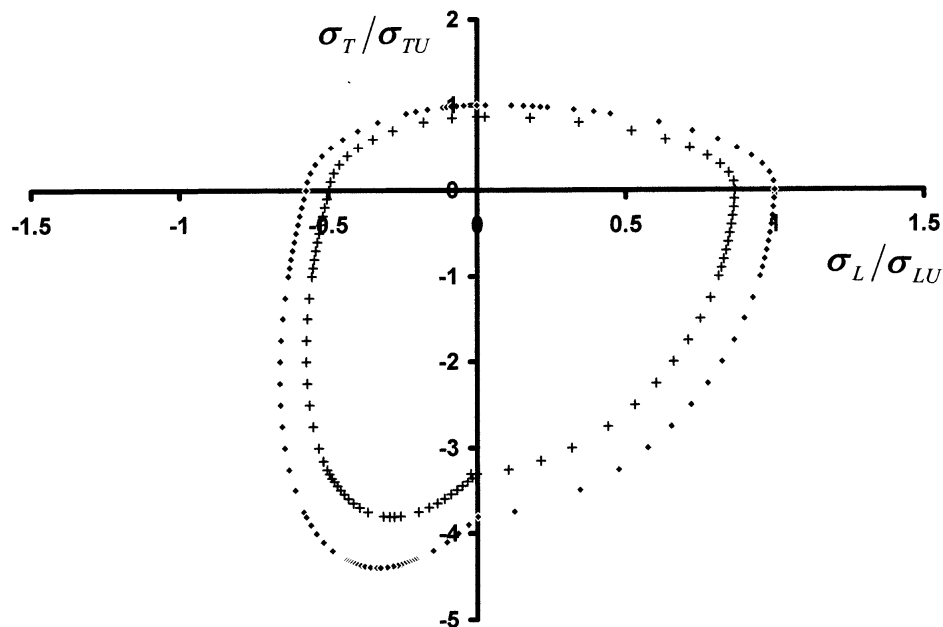

**Figure 6.11. Tsai-Hill Failure Surface Plotted in Normalized Natural Coordinate Stress Space for E-Glass Epoxy Lamina ( $\tau_{LT} / \tau_{LTU} = 0$  and  $0.5$ )**

The failure surface representation of the Tsai-Wu tensor criteria is simply an ellipse in these same natural stress coordinates, as shown in Figure 6.12 below. This plot is based on assuming the interactive strength term  $F_{12}^* = -1/2$ . Again, the addition of a shear stress component reduces the feasible design space.

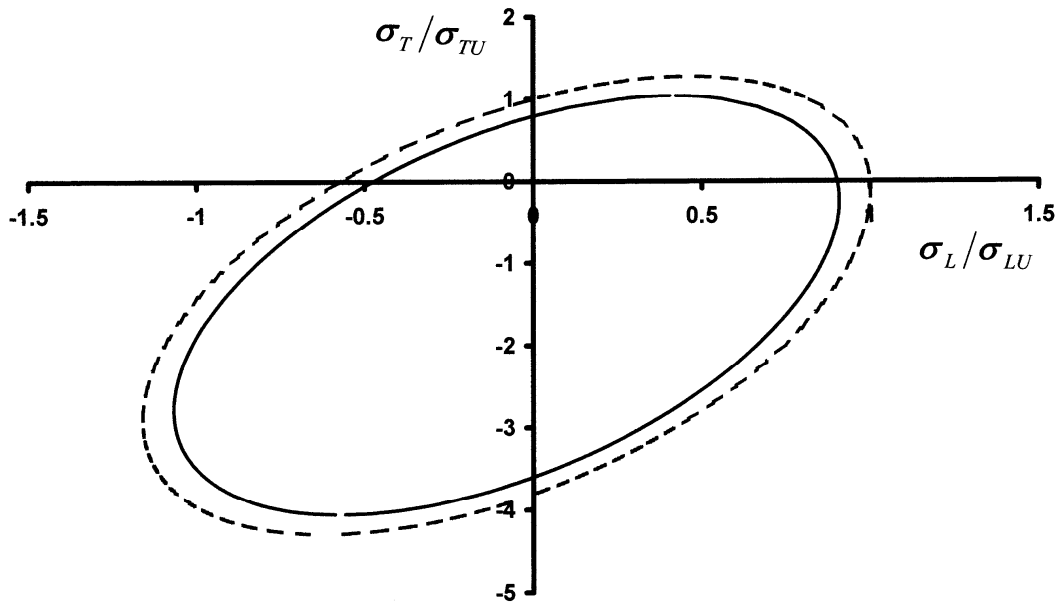
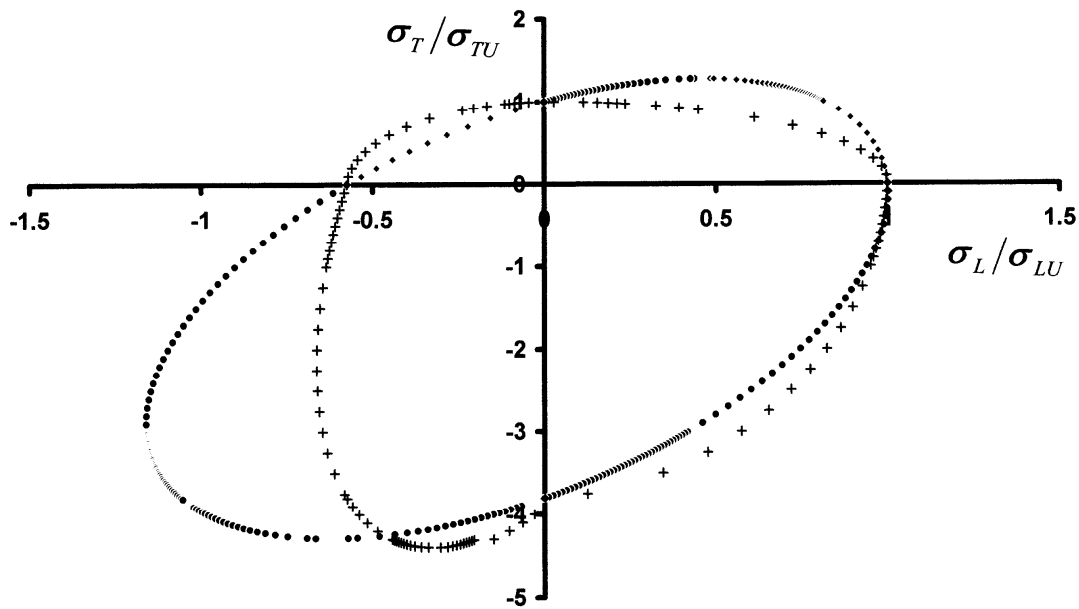

**Figure 6.12. Tsai-Wu Failure Surface Plotted in Normalized Natural Coordinate Stress Space for E-Glass Epoxy Lamina ( $\tau_{LT}/\tau_{LTU} = 0$  and  $0.5$ )**

As with the Tsai-Hill criteria, the compressive stress axes intercepts occur at  $\sigma_T/\sigma_{TU} = \sigma'_{TU}/\sigma_{TU} = 3.806$  and at  $\sigma_L/\sigma_{LU} = \sigma'_{LU}/\sigma_{LU} = 0.5744$  for zero shear stress.

For this particular case of E-glass epoxy, the Tsai-Hill and Tsai-Wu failure surfaces are compared in Figure 6.13 below. Again in this graphical representation, the interactive strength term for the Tsai-Wu criteria is assumed to be  $F_{12}^* = -1/2$ .

Clearly the two failure criteria are in reasonable agreement in three quadrants but differ significantly in the fourth quadrant where both  $\sigma_L$  and  $\sigma_T$  are compressive. Remember that the interactive strength term has been assumed in this case rather than determined through experiment.



**Figure 6.13. Tsai-Hill vs. Tsai-Wu Failure Surfaces Compared for E-Glass Epoxy Lamina ( $\tau_{LT}/\tau_{LTU} = 0$ )**

For the Tsai-Wu failure criteria, it is interesting to note that the interactive strength term  $F_{12}^*$  governs both the slenderness ratio and inclination of the major elliptical axis. The major axis has an inclination of  $+45^\circ$  for negative  $F_{12}^*$  and  $-45^\circ$  for positive  $F_{12}^*$ . This effect of the interactive strength term is demonstrated in Figure 6.14 below for the E-glass epoxy lamina under consideration. The Tsai-Wu failure surfaces are plotted for  $F_{12}^* = -1/2$  and  $F_{12}^* = +1/2$ . Remember that this negative value of  $F_{12}^*$  is the value proposed [24] to make the Tsai-Wu criteria represent a generalized version of the von Mises failure criteria. Figure 6.15 compares the Tsai-Wu failure surface for interactive strength term values  $F_{12}^* = -1/2$  and  $F_{12}^* = -1/4$  to the Tsai-Hill failure surface.

It is observe in Figure 6.15 that varying the interactive strength term from  $-1/2$  to  $-1/4$  brings the Tsai-Wu and Tsai-Hill failure predictions into better agreement in the fourth quadrant of natural stress space. Of course, these interactive strength term values are simply analytical assumptions. These results clearly demonstrate the importance of the interactive strength term in defining the Tsai-Wu failure surface, particularly when the natural stresses  $\sigma_L$  and  $\sigma_T$  are compressive.

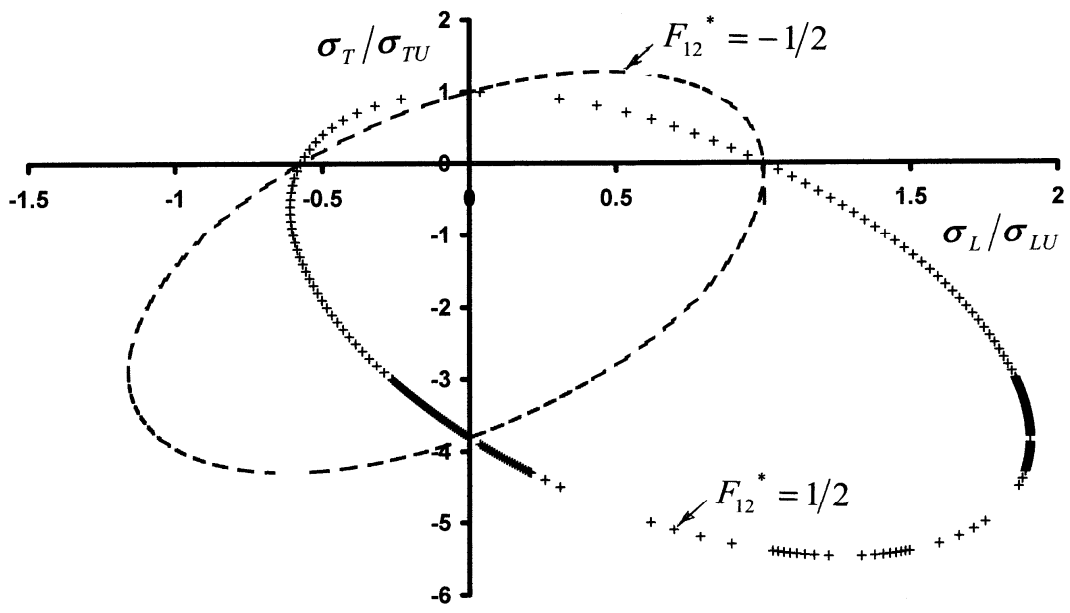

Figure 6.14. Tsai-Wu Failure Surface for E-Glass Epoxy Lamina With Different Interactive Strength Terms ( $\tau_{LT}/\tau_{LTU} = 0$ )

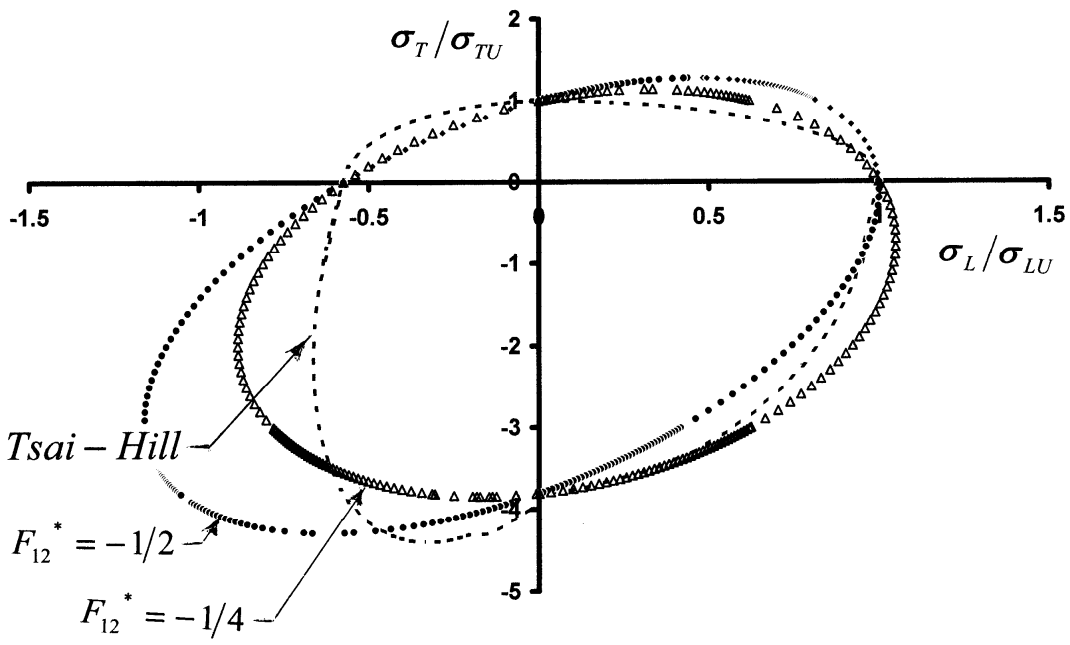

Figure 6.15. Tsai-Wu vs. Tsai-Hill Failure Surfaces for E-Glass Epoxy Lamina with Interactive Strength Terms ( $\tau_{LT}/\tau_{LTU} = 0$ )

### 6.5 Effect of Shear Stress Direction on Lamina Strength

The shear strength of an orthotropic lamina is dependent on the direction of the shear stress when this stress is applied in reference axes different than the material (natural) coordinates. Consider reference axes at an angle of  $45^\circ$  to the natural coordinates as sketched below

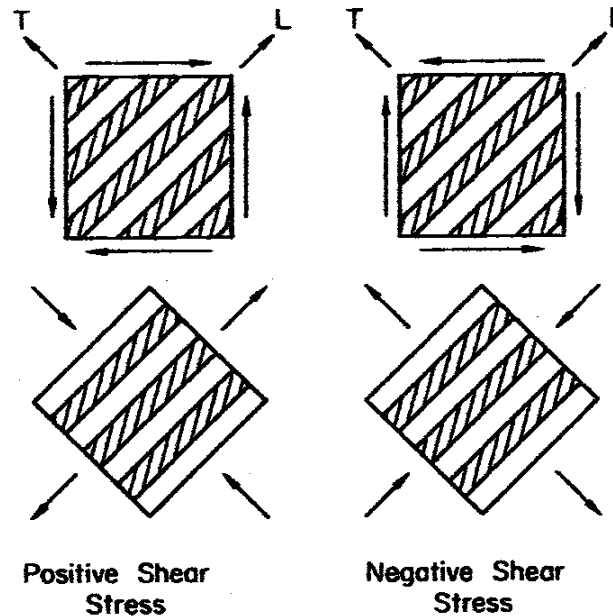

Figure 6.16. Shear Stress  $\tau_{XY}$  Applied in XY Coordinates at  $45^\circ$  to Natural LT Coordinates

Application of the positive shear stress results in a compressive stress in the transverse (T) direction and tensile stress in the fiber (L) direction. Conversely, application of the negative shear stress results in tensile stress in the transverse (T) direction and compressive strength in the fiber (L) direction. Typically,  $\sigma_{TU} < \sigma'_{TU}$  and  $\sigma'_{LU} < \sigma_{LU}$ . Therefore, the lamina in this case is more likely to fail when the negative shear stress is applied. These results can be shown mathematically by going back to the transformation given in equation (5.1). This transformation from reference to natural coordinate stresses can be written in this case as below.

$$\begin{Bmatrix} \sigma_L \\ \sigma_T \\ \tau_{LT} \end{Bmatrix} = [T] \begin{Bmatrix} 0 \\ 0 \\ \tau_{XY} \end{Bmatrix}$$

For  $\theta = 45^\circ$ , the stresses in natural coordinates for positive  $\tau_{XY}$  become

$$\sigma_L = +\tau_{XY} \sin 2\theta = +\tau_{XY}$$

$$\begin{aligned}\sigma_T &= -\tau_{XY} \sin 2\theta = -\tau_{XY} \\ \tau_{LT} &= \tau_{XY} \cos 2\theta = 0\end{aligned}$$

and the sign of these natural stresses reverse for negative  $\tau_{XY}$ . Again, the lamina is more susceptible to failure for the negatively applied shear stress in this case because of differences in strengths in the  $L$  and  $T$  directions. Thus off-axis shear strength of an orthotropic lamina depends not only on the fiber orientation but also on the direction of the applied shear stress.

## 7.0 ANALYSIS OF LAMINATED (MULTI-LAYERED) COMPOSITES

In a unidirectional composite, the ratio of longitudinal strength (or stiffness) to transverse strength (or stiffness) can be varied by changing the constituent materials and also by varying the volume fraction of fibers. Longitudinal behavior is controlled primarily by fiber properties while transverse behavior is matrix dominated. Generally the transverse properties of a unidirectional composite are unsatisfactory in most engineering applications. While this is an undesirable property of unidirectional composites in many instances, this characteristic is overcome by forming laminates from a number of unidirectional layers. A laminate is formed when two or more laminae (plies) are bonded together to act as an integral structure. Each lamina in the laminate has its material (natural) coordinate axes oriented at some desired off-set angle with respect to the reference coordinates. The intent is to achieve a set of desired properties in all directions.

### 7.1 Specifying Stress and Strain Variation in a Laminate

The bond between the laminae is assumed to provide continuity between neighboring plies, i.e., no slippage between plies occurs in an undamaged laminated structure. A relationship is needed to define strain as a function of displacement and curvature. Consider deforming a section of a laminate in the  $x$ - $z$  plane as depicted in Figure 7.1 below. Assume that face ABCD originally straight and perpendicular to the mid-plane of the laminate remains straight and perpendicular to the mid-plane after deformation. This assumption that plane sections remain plane and perpendicular to the mid-plane effectively assumes that the through-the-thickness shear deformations  $\gamma_{xz}$  and  $\gamma_{yz}$  are negligible. This kinematic representation is referred to as the *Kirchoff hypothesis* and is normally a reasonable assumption for thin laminated composite plate and shell structures. The approach taken here is referred to as the *classical lamination theory*, for example see [25].

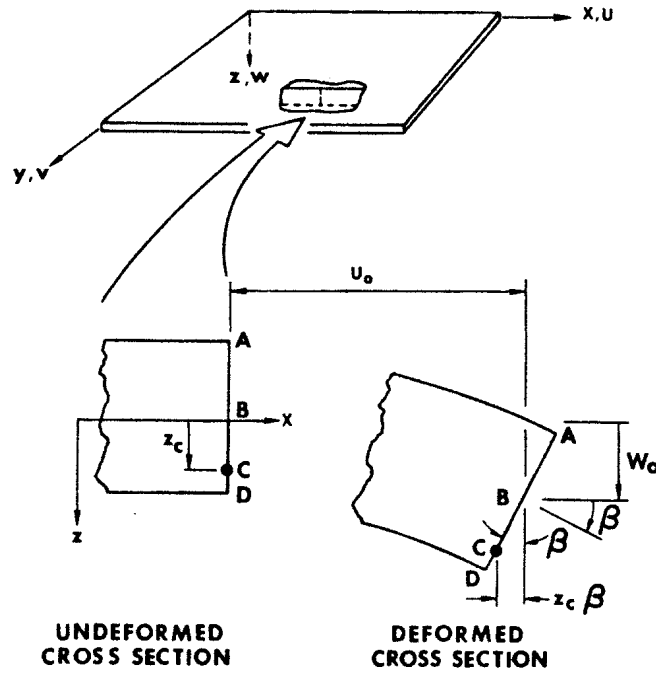

Figure 7.1. Bending of Laminate in X-Z Plane

Assume that point B at the geometric mid-plane undergoes displacements  $u_o, v_o$  and  $w_o$  along the x, y and z axes, respectively. It follows that displacement in the x direction at point C is given as

$$u = u_o - z\beta \quad (7.1)$$

where  $\beta$  is the slope of the laminate mid-plane in the x direction, i.e.,

$$\beta = \frac{\partial w_o}{\partial x} \quad (7.2)$$

Substituting (7.2) into (7.1) gives an expression for displacement in the x direction as

$$u = u_o - z \frac{\partial w_o}{\partial x} \quad (7.3)$$

Similar reasoning for displacement in the y direction at a geometric distance z from the mid-plane gives

$$v = v_o - z \frac{\partial w_o}{\partial y} \quad (7.4)$$

Displacement  $w$  in the  $z$  direction, normal to the laminate plane, is the displacement of the mid-plane  $w_o$  plus the stretching (or shortening) of the normal, i.e.

$$w = w_o + \text{stretching (shortening) of normal}$$

It is assumed that this stretching (shortening) of the normal is negligible relative to the displacement  $w_o$ . Thus the normal (through-the-thickness) strain  $\epsilon_z$  is neglected. This is a reasonable assumption for thin-walled composite structures. This assumption results in the interlaminar shear strains being zero. This result is shown by substituting (7.3) and the assumption that  $w = w_o$  into the appropriate strain displacement relation. This gives

$$\gamma_{xz} = \frac{\partial u}{\partial z} + \frac{\partial w}{\partial x} = -\frac{\partial w_o}{\partial x} + \frac{\partial w_o}{\partial x} = 0$$

similarly

$$\gamma_{yz} = \frac{\partial v}{\partial z} + \frac{\partial w}{\partial y} = -\frac{\partial w_o}{\partial y} + \frac{\partial w_o}{\partial y} = 0$$

and thus the nontrivial laminate strains reduce to  $\epsilon_x$ ,  $\epsilon_y$ , and  $\gamma_{xy}$ . These strains are defined for the derived displacements as

$$\begin{aligned} \epsilon_x &= \frac{\partial u}{\partial x} = \frac{\partial u_o}{\partial x} - z \frac{\partial^2 w_o}{\partial x^2} \\ \epsilon_y &= \frac{\partial v}{\partial y} = \frac{\partial v_o}{\partial y} - z \frac{\partial^2 w_o}{\partial y^2} \\ \gamma_{xy} &= \frac{\partial u}{\partial y} + \frac{\partial v}{\partial x} = \frac{\partial u_o}{\partial y} + \frac{\partial v_o}{\partial x} - 2z \frac{\partial^2 w_o}{\partial x \partial y} \end{aligned} \quad (7.5)$$

These relationships can be written in matrix form as the sum of mid-plane strains and plate curvatures.

$$\begin{Bmatrix} \epsilon_x \\ \epsilon_y \\ \gamma_{xy} \end{Bmatrix} = \begin{Bmatrix} \epsilon_x^o \\ \epsilon_y^o \\ \gamma_{xy}^o \end{Bmatrix} + z \begin{Bmatrix} k_x \\ k_y \\ k_{xy} \end{Bmatrix} \quad (7.6)$$

The mid-plane strains are written as below.

$$\begin{Bmatrix} \varepsilon_X^o \\ \varepsilon_Y^o \\ \gamma_{XY}^o \end{Bmatrix} = \begin{Bmatrix} \frac{\partial u_o}{\partial x} \\ \frac{\partial v_o}{\partial y} \\ \frac{\partial u_o}{\partial y} + \frac{\partial v_o}{\partial x} \end{Bmatrix} \quad (7.7)$$

The plate curvatures are given as

$$\begin{Bmatrix} k_X \\ k_Y \\ k_{XY} \end{Bmatrix} = - \begin{Bmatrix} \frac{\partial^2 w_o}{\partial x^2} \\ \frac{\partial^2 w_o}{\partial y^2} \\ 2 \frac{\partial^2 w_o}{\partial x \partial y} \end{Bmatrix} \quad (7.8)$$

Equation (7.6) represents a **linear variation in strains through the thickness of the laminate**. The laminate is comprised of a set of laminae and the stresses in any given lamina (ply), e.g. the  $k^{\text{th}}$ , can be defined by substituting (7.6) into the stress-strain relationship (5.21). The result is written for the  $k^{\text{th}}$  lamina(ply) as

$$\begin{Bmatrix} \sigma_X \\ \sigma_Y \\ \tau_{XY} \end{Bmatrix}_K = \begin{bmatrix} \bar{Q}_{11} & \bar{Q}_{12} & \bar{Q}_{16} \\ \bar{Q}_{12} & \bar{Q}_{22} & \bar{Q}_{26} \\ \bar{Q}_{16} & \bar{Q}_{26} & \bar{Q}_{66} \end{bmatrix}_K \begin{Bmatrix} \varepsilon_X^o \\ \varepsilon_Y^o \\ \gamma_{XY}^o \end{Bmatrix} + z \begin{bmatrix} \bar{Q}_{11} & \bar{Q}_{12} & \bar{Q}_{16} \\ \bar{Q}_{12} & \bar{Q}_{22} & \bar{Q}_{26} \\ \bar{Q}_{16} & \bar{Q}_{26} & \bar{Q}_{66} \end{bmatrix}_K \begin{Bmatrix} k_X \\ k_Y \\ k_{XY} \end{Bmatrix} \quad (7.9)$$

**While the strain variation is linear through the thickness of the laminate, stress variation is not linear.** The stress gradient varies from lamina to lamina and can differ for adjoining lamina. Furthermore, stresses are discontinuous at the interface of adjoining lamina. An example of the stress and strain variation through the thickness of a three ply laminate is shown in Figure 7.2 below. The differences in stiffness lead to differences in stress between adjoining lamina.

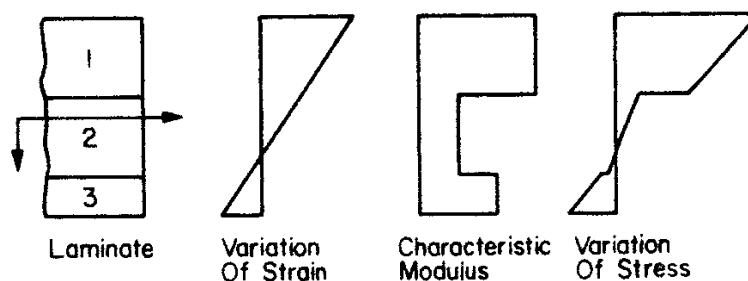

**Figure 7.2 Hypothetical Three-Ply Laminate with Stress, Strain Variation**

## 7.2 Relating Resultant Forces and Moments to Strain and Curvature

It is convenient to work with an equivalent system of forces and moments acting on the laminate cross section as shown in Figure 7.3.

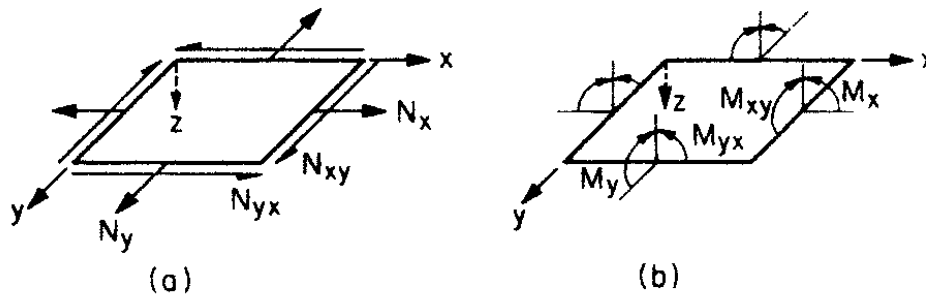

**Figure 7.3 Resultant Forces and Moments Acting on Laminate**

Resultant forces are obtained by integrating the appropriate stresses through the laminate thickness ( $h$ ). These resultant forces have units of force per unit width and are written below for a laminate of thickness  $h$ .

$$N_X = \int_{-h/2}^{h/2} \sigma_X dz$$

$$N_Y = \int_{-h/2}^{h/2} \sigma_Y dz \quad (7.10)$$

$$N_{XY} = \int_{-h/2}^{h/2} \tau_{XY} dz$$

Resultant moments are obtained by integrating through the laminate thickness as with the forces, but in this case moment is obtained by multiplying stress by the moment arm with respect to the laminate mid-plane. These moments are defined as follows

$$M_X = \int_{-h/2}^{h/2} \sigma_X z dz$$

$$M_Y = \int_{-h/2}^{h/2} \sigma_Y z dz \quad (7.11)$$

$$M_{XY} = \int_{-h/2}^{h/2} \tau_{XY} z dz$$

The positive sign convention for these resultant forces and moments is shown in Figure 7.3. Note that the six force and moment resultants form a system that is statically equivalent to the stresses acting on the laminate. This resultant force/moment system acts at the geometric mid-plane of the laminate.

The continuous integrals in (7.10) and (7.11) can be replaced by the summation of integrals over the  $n$  orthotropic laminae represented in Figure 7.4 below.

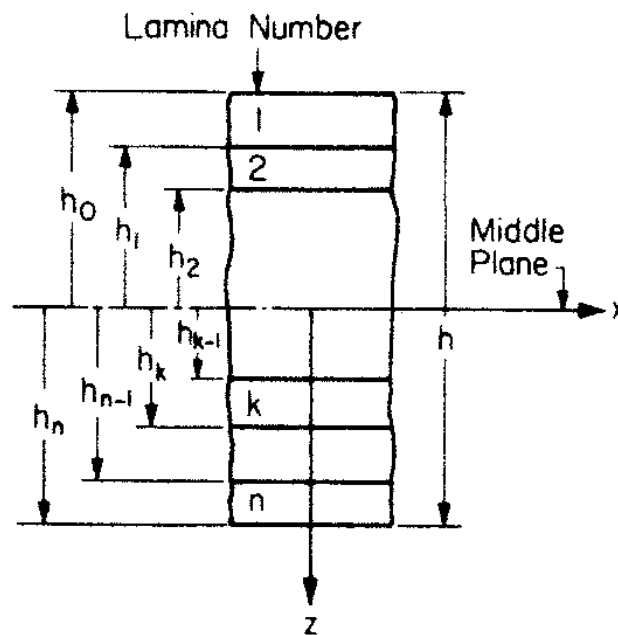

**Figure 7.4 Multi-layered Laminate Geometry with  $n$  Laminae (Plies)**

These summations have the matrix form

$$\{N\} = \begin{Bmatrix} N_X \\ N_Y \\ N_{XY} \end{Bmatrix} = \sum_{K=1}^n \int_{h_{K-1}}^{h_K} \begin{Bmatrix} \sigma_X \\ \sigma_Y \\ \tau_{XY} \end{Bmatrix}_K dz \quad (7.12)$$

and

$$\{M\} = \begin{Bmatrix} M_X \\ M_Y \\ M_{XY} \end{Bmatrix} = \sum_{K=1}^n \int_{h_{K-1}}^{h_K} \begin{Bmatrix} \sigma_X \\ \sigma_Y \\ \tau_{XY} \end{Bmatrix}_K z dz \quad (7.13)$$

These resultant forces and moments can be related to mid-plane strains and plate curvatures by substituting (7.9) into (7.12) and (7.13). The resultant forces become

$$\begin{Bmatrix} N_X \\ N_Y \\ N_{XY} \end{Bmatrix} = \sum_{K=1}^n [\bar{Q}]_K \left\{ \int_{h_{K-1}}^{h_K} \begin{Bmatrix} \varepsilon_X^o \\ \varepsilon_Y^o \\ \gamma_{XY}^o \end{Bmatrix} dz + \int_{h_{K-1}}^{h_K} \begin{Bmatrix} k_X \\ k_Y \\ k_{XY} \end{Bmatrix} z dz \right\} \quad (7.14)$$

or in simplified matrix notation

$$\begin{Bmatrix} N_X \\ N_Y \\ N_{XY} \end{Bmatrix} = [A] \begin{Bmatrix} \varepsilon_X^o \\ \varepsilon_Y^o \\ \gamma_{XY}^o \end{Bmatrix} + [B] \begin{Bmatrix} k_X \\ k_Y \\ k_{XY} \end{Bmatrix} \quad (7.15)$$

where the coefficients in  $[A]$  and  $[B]$  are defined as

$$A_{ij} = \sum_{K=1}^n (\bar{Q}_{ij})_K (h_K - h_{K-1}) \quad (7.16)$$

$$B_{ij} = \frac{1}{2} \sum_{K=1}^n (\bar{Q}_{ij})_K (h_K^2 - h_{K-1}^2) \quad (7.17)$$

Similarly the resultant moments come from substituting (7.9) into (7.13).

$$\begin{Bmatrix} M_X \\ M_Y \\ M_{XY} \end{Bmatrix} = \sum_{K=1}^n [\bar{Q}]_K \left\{ \int_{h_{K-1}}^{h_K} \begin{Bmatrix} \varepsilon_X^o \\ \varepsilon_Y^o \\ \gamma_{XY}^o \end{Bmatrix} z dz + \int_{h_{K-1}}^{h_K} \begin{Bmatrix} k_X \\ k_Y \\ k_{XY} \end{Bmatrix} z^2 dz \right\} \quad (7.18)$$

In simplified matrix notation the resultant moments become

$$\begin{Bmatrix} M_X \\ M_Y \\ M_{XY} \end{Bmatrix} = [D] \begin{Bmatrix} \varepsilon_X^o \\ \varepsilon_Y^o \\ \gamma_{XY}^o \end{Bmatrix} + [D] \begin{Bmatrix} k_X \\ k_Y \\ k_{XY} \end{Bmatrix} \quad (7.19)$$

Here the coefficients in  $[D]$  are defined as

$$D_{ij} = \frac{1}{3} \sum_{K=1}^n (\bar{Q}_{ij})_K (h_K^3 - h_{K-1}^3) \quad (7.20)$$

The total set of six constitutive equations for the laminated plate can be written in compact matrix form as

$$\begin{Bmatrix} [N] \\ [M] \end{Bmatrix} = \begin{bmatrix} [A] & [B] \\ [B] & [D] \end{bmatrix} \begin{Bmatrix} \{\boldsymbol{\varepsilon}^o\} \\ \{k\} \end{Bmatrix} \quad (7.21)$$

Here,  $[A]$  is denoted the extensional stiffness matrix.  $[B]$  is defined as the coupling stiffness matrix and  $[D]$  is the bending stiffness matrix. The mid-plane strains and plate curvatures are defined as

$$\{\boldsymbol{\varepsilon}^o\} = \begin{Bmatrix} \boldsymbol{\varepsilon}_X^o \\ \boldsymbol{\varepsilon}_Y^o \\ \boldsymbol{\gamma}_{XY}^o \end{Bmatrix} \quad (7.22)$$

$$\{k\} = \begin{Bmatrix} k_X \\ k_Y \\ k_{XY} \end{Bmatrix} \quad (7.23)$$

The extensional stiffness matrix  $[A]$  relates the mid-plane strains  $\{\boldsymbol{\varepsilon}^o\}$  to the resultant in-plane forces, while the bending stiffness matrix  $[D]$  relates the plate curvatures  $\{k\}$  to the resultant moments. Stretching a laminate with nonzero  $B_{ij}$  terms will result in bending and/or twisting of the laminate along with extensional and shear deformation. Note that coupling between the extension and bending/twisting of a laminate with nonzero  $B_{ij}$  is not caused by the orthotropy of the plies, but instead is due to nonsymmetric stacking of the laminate. Ashton et al [26] demonstrated the phenomenon of coupling between stretching and twisting by applying a simple axial load  $N_x$  to a two ply  $[\pm\theta]$  specimen. In their experiment the resultant axial load is related to strain and curvature as

$$N_x = A_{11}\boldsymbol{\varepsilon}_X^o + A_{12}\boldsymbol{\varepsilon}_Y^o + B_{16}k_{XY}$$

thus the application of axial load  $N_x$  produces twisting curvature  $k_{XY}$ .

The stiffness matrix relationship given in (7.21) provides a means of determining the laminate strains and curvatures for a set of applied forces and moments. Having determined strains and curvatures, the stresses can be calculated on a ply by ply basis from the constitutive equations given in (7.9). These stresses in reference XY coordinates can then be transformed to natural coordinates for each ply by applying the coordinate transformation given in (5.1). Any of the failure theories can be applied in each ply to determine the factor of safety for the laminate.

### 7.3 Including Hygrothermal Effects in Laminate Analysis

Thermal and hygroscopic strains can occur in a body due to temperature and hygroscopic (moisture) changes. Thermal strain in an isotropic material is defined as the product of the thermal coefficient of expansion  $\alpha$  and the change in temperature  $\Delta T$ . Similarly, the hygroscopic strain is defined as the product of the coefficient of moisture expansion  $\beta$  and the change in moisture content  $\Delta C$ . These strains are written as

$$\boldsymbol{\varepsilon}^T = \alpha \Delta T \quad (7.24)$$

$$\boldsymbol{\varepsilon}^H = \beta \Delta C \quad (7.25)$$

For orthotropic materials, the coefficients of thermal and moisture expansion are directionally dependent as is the case for other constitutive properties. Therefore, changes in temperature and/or moisture produce differences in the longitudinal (along the fiber reinforcement) and transverse strains (perpendicular to fibers). The thermal strains in the longitudinal and transverse directions are defined as

$$\boldsymbol{\varepsilon}_L^T = \alpha_L \Delta T \quad (7.26)$$

$$\boldsymbol{\varepsilon}_T^T = \alpha_T \Delta T$$

Here  $\alpha_L$  and  $\alpha_T$  represent the thermal coefficients of expansion in the longitudinal and transverse directions, respectively. Similarly, the hygroscopic strains are given as

$$\boldsymbol{\varepsilon}_L^H = \beta_L \Delta C \quad (7.27)$$

$$\boldsymbol{\varepsilon}_T^H = \beta_T \Delta C$$

Here  $\beta_L$  and  $\beta_T$  represent the moisture expansion coefficients in the longitudinal and transverse directions, respectively.

Total strains can be defined as the sum of the elastic (mechanical) strains and the hygrothermal strains. These strains are written in concise matrix form as below

$$\{\boldsymbol{\varepsilon}\}_{TOTAL} = \{\boldsymbol{\varepsilon}\}_{ELASTIC} + \{\boldsymbol{\varepsilon}\}_{HYGROTHERMAL} \quad (7.28)$$

Rearranging the above, the elastic (mechanical) strains in reference coordinates can be equated to the total strains minus the thermal and hygroscopic strains. The mechanical strains are then given as

$$\begin{Bmatrix} \varepsilon_X^M \\ \varepsilon_Y^M \\ \varepsilon_Z^M \end{Bmatrix} = \begin{Bmatrix} \varepsilon_X \\ \varepsilon_Y \\ \varepsilon_Z \end{Bmatrix} - \begin{Bmatrix} \varepsilon_X^T \\ \varepsilon_Y^T \\ \varepsilon_Z^T \end{Bmatrix} - \begin{Bmatrix} \varepsilon_X^H \\ \varepsilon_Y^H \\ \varepsilon_Z^H \end{Bmatrix} \quad (7.28)$$

A simple 1-D analogy of the above matrix equation consists of an axial bar constrained at its ends and subjected to an increase in temperature. Assuming the bar is made of an isotropic material, the thermal stress is calculated as

$$\varepsilon_{ELASTIC} = \varepsilon_{TOTAL} - \alpha\Delta T$$

or from Hooke's law

$$\frac{\sigma}{E} = 0 - \alpha\Delta T$$

and finally

$$\sigma = -\alpha E\Delta T$$

for the constrained axial bar. The same basic approach can be used to calculate stresses/strains in orthotropic laminates subjected to hygrothermal effects.

Coefficients of thermal and moisture expansion can be transformed from natural  $LT$  coordinates to the reference  $XY$  coordinates for the laminate by the following transformation

$$\begin{Bmatrix} \alpha_X \\ \alpha_Y \\ \alpha_{XY}/2 \end{Bmatrix} = [T]^{-1} \begin{Bmatrix} \alpha_L \\ \alpha_T \\ 0 \end{Bmatrix} \quad (7.29)$$

and

$$\begin{Bmatrix} \beta_X \\ \beta_Y \\ \beta_{XY}/2 \end{Bmatrix} = [T]^{-1} \begin{Bmatrix} \beta_L \\ \beta_T \\ 0 \end{Bmatrix} \quad (7.30)$$

Coordinate transformation  $[T^{-1}]$  has been previously defined in equation (5.6). Expanding (7.29) gives definition of the thermal coefficients of expansion in reference coordinates for a given ply at off-set angle  $\theta$  as

$$\begin{aligned}
\alpha_x &= \cos^2(\theta)\alpha_L + \sin^2(\theta)\alpha_T \\
\alpha_y &= \sin^2(\theta)\alpha_L + \cos^2(\theta)\alpha_T \\
\alpha_{xy} &= 2\sin(\theta)\cos(\theta)\alpha_L - 2\sin(\theta)\cos(\theta)\alpha_T
\end{aligned} \tag{7.31}$$

Of course, the moisture expansion coefficients in reference coordinates can be similarly defined by expanding (7.30).

With the expansion coefficients defined in reference coordinates, the thermal and hygroscopic strains can be defined as below

$$\begin{Bmatrix} \varepsilon_X^T \\ \varepsilon_Y^T \\ \gamma_{XY}^T \end{Bmatrix} = \begin{Bmatrix} \alpha_X \\ \alpha_Y \\ \alpha_{XY} \end{Bmatrix} \Delta T \tag{7.32}$$

and

$$\begin{Bmatrix} \varepsilon_X^H \\ \varepsilon_Y^H \\ \gamma_{XY}^H \end{Bmatrix} = \begin{Bmatrix} \beta_X \\ \beta_Y \\ \beta_{XY} \end{Bmatrix} \Delta C \tag{7.33}$$

Substituting (7.6), (7.32) and (7.33) into (7.28) provides definition of the mechanical (elastic) strains in terms of total mid-plane strains, total plate curvatures and change in temperature and moisture. This matrix equation takes the form

$$\begin{Bmatrix} \varepsilon_X^M \\ \varepsilon_Y^M \\ \gamma_{XY}^M \end{Bmatrix} = \begin{Bmatrix} \varepsilon_X^o \\ \varepsilon_Y^o \\ \gamma_{XY}^o \end{Bmatrix} + z \begin{Bmatrix} k_X \\ k_Y \\ k_{XY} \end{Bmatrix} - \begin{Bmatrix} \alpha_X \\ \alpha_Y \\ \alpha_{XY} \end{Bmatrix} \Delta T - \begin{Bmatrix} \beta_X \\ \beta_Y \\ \beta_{XY} \end{Bmatrix} \Delta C \tag{7.34}$$

Based on matrix equation (5.21) the lamina hygrothermal stresses can be written as

$$\begin{Bmatrix} \sigma_X^T \\ \sigma_Y^T \\ \tau_{XY}^T \end{Bmatrix} = [\bar{Q}] \begin{Bmatrix} \varepsilon_X^M \\ \varepsilon_Y^M \\ \gamma_{XY}^M \end{Bmatrix} \tag{7.35}$$

Substituting (7.34) into (7.35) provides definition of the hygrothermal stresses at the lamina (ply) level as

$$\begin{Bmatrix} \sigma_X^T \\ \sigma_Y^T \\ \tau_{XY}^T \end{Bmatrix} = [\bar{Q}] \begin{Bmatrix} \varepsilon_X^o \\ \varepsilon_Y^o \\ \gamma_{XY}^o \end{Bmatrix} + z \begin{Bmatrix} k_X \\ k_Y \\ k_{XY} \end{Bmatrix} - \begin{Bmatrix} \alpha_X \\ \alpha_Y \\ \alpha_{XY} \end{Bmatrix} \Delta T - \begin{Bmatrix} \beta_X \\ \beta_Y \\ \beta_{XY} \end{Bmatrix} \Delta C \quad (7.36)$$

This matrix equation must be solved for the total mid-plane strains and curvatures caused by hygrothermal effects. This is accomplished by first substituting (7.36) into (7.12) and assuming there are no applied loads. We have

$$\begin{Bmatrix} 0 \\ 0 \\ 0 \end{Bmatrix} = [A] \begin{Bmatrix} \varepsilon_X^o \\ \varepsilon_Y^o \\ \gamma_{XY}^o \end{Bmatrix} + [B] \begin{Bmatrix} k_X \\ k_Y \\ k_{XY} \end{Bmatrix} - \sum_{K=1}^n [\bar{Q}]_K \begin{Bmatrix} \alpha_X \\ \alpha_Y \\ \alpha_{XY} \end{Bmatrix}_K (h_K - h_{K-1}) \Delta T \\ - \sum_{K=1}^n [\bar{Q}]_K \begin{Bmatrix} \beta_X \\ \beta_Y \\ \beta_{XY} \end{Bmatrix}_K (h_K - h_{K-1}) \Delta C \quad (7.37)$$

In order to simplify the above equation and provide a form amenable to solution, define the *apparent hygrothermal forces* as below

$$\begin{Bmatrix} N_X^T \\ N_Y^T \\ N_{XY}^T \end{Bmatrix} = \sum_{K=1}^n [\bar{Q}]_K \begin{Bmatrix} \alpha_X \\ \alpha_Y \\ \alpha_{XY} \end{Bmatrix}_K (h_K - h_{K-1}) \Delta T \quad (7.38)$$

$$\begin{Bmatrix} N_X^H \\ N_Y^H \\ N_{XY}^H \end{Bmatrix} = \sum_{K=1}^n [\bar{Q}]_K \begin{Bmatrix} \beta_X \\ \beta_Y \\ \beta_{XY} \end{Bmatrix}_K (h_K - h_{K-1}) \Delta C \quad (7.39)$$

Matrix equation (7.37) can now be written in the form

$$\begin{Bmatrix} N_X^T \\ N_Y^T \\ N_{XY}^T \end{Bmatrix} + \begin{Bmatrix} N_X^H \\ N_Y^H \\ N_{XY}^H \end{Bmatrix} = [A] \begin{Bmatrix} \varepsilon_X^o \\ \varepsilon_Y^o \\ \gamma_{XY}^o \end{Bmatrix} + [B] \begin{Bmatrix} k_X \\ k_Y \\ k_{XY} \end{Bmatrix} \quad (7.40)$$

Note that (7.40) has the exact matrix form of (7.15) except that the loads on the left hand side of the equation are now the apparent hygrothermal loads instead of the applied external loads.

To complete the equation set required for solution, substitute (7.36) into (7.13) and assume there are no applied moments. This gives

$$\begin{aligned}
\begin{Bmatrix} 0 \\ 0 \\ 0 \end{Bmatrix} &= [B] \begin{Bmatrix} \varepsilon_X^o \\ \varepsilon_Y^o \\ \gamma_{XY}^o \end{Bmatrix} + [D] \begin{Bmatrix} k_X \\ k_Y \\ k_{XY} \end{Bmatrix} - \frac{1}{2} \sum_{K=1}^n [\bar{Q}]_K \begin{Bmatrix} \alpha_X \\ \alpha_Y \\ \alpha_{XY} \end{Bmatrix}_K (h_K^2 - h_{K-1}^2) \Delta T \\
&\quad - \frac{1}{2} \sum_{K=1}^n [\bar{Q}]_K \begin{Bmatrix} \beta_X \\ \beta_Y \\ \beta_{XY} \end{Bmatrix}_K (h_K^2 - h_{K-1}^2) \Delta C
\end{aligned} \tag{7.41}$$

Similar to the approach in defining the apparent hygrothermal forces, now define the *apparent hygrothermal moments* as below

$$\begin{Bmatrix} M_X^T \\ M_Y^T \\ M_{XY}^T \end{Bmatrix} = \frac{1}{2} \sum_{K=1}^n [\bar{Q}]_K \begin{Bmatrix} \alpha_X \\ \alpha_Y \\ \alpha_{XY} \end{Bmatrix}_K (h_K^2 - h_{K-1}^2) \Delta T \tag{7.42}$$

$$\begin{Bmatrix} M_X^H \\ M_Y^H \\ M_{XY}^H \end{Bmatrix} = \frac{1}{2} \sum_{K=1}^n [\bar{Q}]_K \begin{Bmatrix} \beta_X \\ \beta_Y \\ \beta_{XY} \end{Bmatrix}_K (h_K^2 - h_{K-1}^2) \Delta C \tag{7.43}$$

Matrix equation (7.41) can now be written as

$$\begin{Bmatrix} M_X^T \\ M_Y^T \\ M_{XY}^T \end{Bmatrix} + \begin{Bmatrix} M_X^H \\ M_Y^H \\ M_{XY}^H \end{Bmatrix} = [B] \begin{Bmatrix} \varepsilon_X^o \\ \varepsilon_Y^o \\ \gamma_{XY}^o \end{Bmatrix} + [D] \begin{Bmatrix} k_X \\ k_Y \\ k_{XY} \end{Bmatrix} \tag{7.44}$$

Note that (7.44) has the same matrix form as (7.19) except that apparent hygrothermal moments replace the applied external moments.

It is clear that the applied external loads can be combined with the apparent hygrothermal loads as

$$[N] = \begin{Bmatrix} N_X \\ N_Y \\ N_{XY} \end{Bmatrix} + \begin{Bmatrix} N_X^T \\ N_Y^T \\ N_{XY}^T \end{Bmatrix} + \begin{Bmatrix} N_X^H \\ N_Y^H \\ N_{XY}^H \end{Bmatrix} \tag{7.45}$$

and the applied external moments can be combined with the apparent hygrothermal moments as

$$[M] = \begin{Bmatrix} M_X \\ M_Y \\ M_{XY} \end{Bmatrix} + \begin{Bmatrix} M_X^T \\ M_Y^T \\ M_{XY}^T \end{Bmatrix} + \begin{Bmatrix} M_X^H \\ M_Y^H \\ M_{XY}^H \end{Bmatrix} \quad (7.46)$$

The governing matrix equation to be solved for the mid-plane strains and curvatures is again (7.21) and repeated below

$$\begin{Bmatrix} [N] \\ [M] \end{Bmatrix} = \begin{pmatrix} [A] & [B] \\ [B] & [D] \end{pmatrix} \begin{Bmatrix} \{\epsilon^o\} \\ \{k\} \end{Bmatrix} \quad (7.21)$$

Here the loads and moments on the left hand side of the equation can contain externally applied loads/moments as well as apparent hygrothermal loads/moments.

The stiffness matrix relationship (7.21) is solved for the total mid-plane strains and laminate curvatures. These values are then substituted into (7.34) to determine the mechanical (elastic) strains in each lamina (ply). Stresses are determined in each ply from the constitutive equations (5.21)

Whenever the hygrothermal state of a laminate differs from its stress-free state, hygrothermal stresses are induced in the laminae (plies) making up the laminate. An example of such effects occurs due to fabrication of composite laminates. Thermal stresses are induced while cooling the laminate down from the extreme fabrication temperatures to room temperature. These thermal stresses can be thought of as residual stresses or curing stresses. They are brought about because of differences in thermal coefficient expansion and the stacking sequence of the laminate. An autoclave cure cycle is shown in Figure 7.5 to indicate the temperature extremes that might be expected during fabrication of a composite laminate.

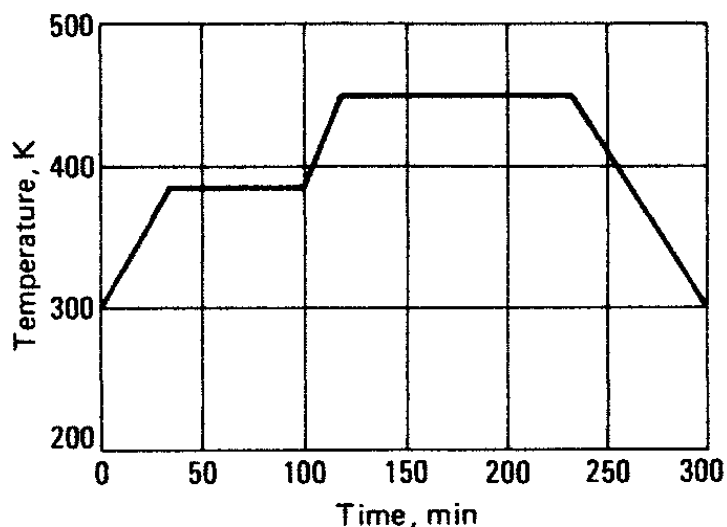

**Figure 7.5 Typical Autoclave Thermoset Cure Cycle for Laminate**

Such residual thermal stresses should be considered as part of the design process as they may be nontrivial.

For any general unsymmetric laminate, based on equations (7.40) and (7.44), any hygrothermal change in temperature or moisture will induce not only extensional strains but also warping of the laminate as exhibited by the existence of plate curvatures  $\{k\}$ . This is not the case for symmetric laminates for which the coupling stiffness matrix  $[B]$  is identically zero. Furthermore, the hygrothermal moments as defined in (7.42) and (7.43) are also zero for symmetric laminates. Therefore there is no significant hygrothermal warpage of symmetric laminates during the fabrication process.

Stresses induced at the fiber-matrix interface, due to the fabrication process, are generally beneficial to shear transfer between the fiber and matrix material. These internal stresses can be calculated through micromechanics analysis and are beyond the scope of the laminate analysis presented here.

It is noted and should be obvious that hygrothermal effects may be caused by many factors in the design environment other than those occurring during the fabrication process. In such cases, these hygrothermal effects can be combined with applied loads as discussed and included in the analysis when solving (7.21) for strains and curvatures and ultimately for stresses at the ply level.

#### 7.4 Construction and Properties of Various Laminates

Derivation of the laminate stiffness matrices is based on summing the effects of the stiffness matrices  $[\bar{Q}]_K$  over each ply (lamina). When the laminate is comprised of a number of orthotropic lamina stacked at arbitrary off-set angles  $\theta$  then the laminate stiffness matrices are generally fully populated with non-zero terms. This result often leads to undesirable coupling between bending or twisting and extension. Therefore laminates with arbitrary stacking sequences usually exhibit unwanted stresses and/or deformation. It is common design practice to specify laminate stacking sequences that result in a number of the laminate stiffness terms being zero. Thus there are special laminate constructions that eliminate undesirable coupling effects.

A laminate orientation code is required to specify (1) the orientation of each ply with respect to a reference axis, (2) the number of plies making up the laminate and (3) the stacking sequence of the plies. The stacking sequence is enclosed in brackets. With this code, each ply is denoted by an angle  $\pm\theta$  and separated from neighboring plies with a slash. Plies are listed in a stacking sequence from one laminate face to the other. Furthermore, adjacent plies of the same orientation are denoted by a numerical subscript. Laminates which exhibit symmetry about the geometric mid-plane require that only half of the stacking sequence be specified. For these symmetric laminates, plies are defined from one laminate face to the mid-plane and the bracketed stacking sequence includes a subscript S to denote that only half of the laminate is presented, i.e., with the other half symmetric about the mid-plane.

To illustrate this laminate orientation code, here are two simple examples of laminates. The first laminate is defined as  $[\pm 45/\mp 30/0]$  where starting at the top face of the laminate the ply stacking sequence has the order  $+45^\circ, -45^\circ, -30^\circ, +30^\circ, 0^\circ$ . A second laminate with symmetry about its geometric mid-plane is defined as  $[45/0_2/90]_S$ . This symmetric laminate has the following ply stacking sequence order  $+45^\circ, 0^\circ, 0^\circ, 90^\circ, 90^\circ, 0^\circ, 0^\circ, +45^\circ$ .

Note that a symmetric laminate with an odd number of plies would be coded as a symmetric laminate except that the center ply would be over-scored. It is also useful to define sets as repeating sequences of plies. Sets are enclosed in parenthesis and adhere to the same rules as applied to an individual ply. A simple example of a laminate with repeating sets might be defined as  $[(45/0/90)_2]_S$ . Here the stacking sequence represented has the order  $+45^\circ, 0^\circ, 90^\circ, +45^\circ, 0^\circ, 90^\circ, 90^\circ, 0^\circ, 45^\circ, 90^\circ, 0^\circ, +45^\circ$ .

When identifying hybrid laminates the laminate orientation code is somewhat modified. Hybrid laminates have plies made up from more than one type of fiber reinforced material. Thus the orientation code for hybrids must include with each ply angle a subscript defining ply material.

#### 7.4.1 Symmetric Laminates

Laminate analysis is greatly simplified if the coupling stiffness matrix  $[B]$  is identically zero. Furthermore, this eliminates undesirable coupling between bending or twisting and extension. Contribution of a ply above the geometric mid-plane of the laminate is nullified by an identical ply, i.e., same stiffness properties and off-set angle, equally distant below the mid-plane. Each  $k^{\text{th}}$  lamina contributes to particular terms in the coupling stiffness as terms in  $[\bar{Q}]_K$  multiplied by the squares of the  $z$  coordinates of the top and bottom of each ply. Consider a ply above and a ply below the mid-plane each with identical stiffness properties and equidistant from the mid-plane. Considering these particular lamina, the contribution of a particular term to the coupling stiffness would appear as below

$$B_{ij} = \bar{Q}_{ij}(h^2_{K+2} - h^2_{K+1}) + \bar{Q}_{ij}(h^2_{K-1} - h^2_{K-2})$$

From symmetry,  $h^2_{K+2} = h^2_{K-2}$  and  $h^2_{K+1} = h^2_{K-1}$ . Therefore

$$B_{ij} = \bar{Q}_{ij}(0) = 0$$

Thus the coupling stiffness matrix  $[B]$  is identically zero for symmetric laminates.

#### 7.4.2 Unidirectional, Cross-Ply and Angle-Ply Laminates

It is possible to have a laminate act as a specially orthotropic layer with respect to in-plane forces and strains. For such laminates there is no coupling between normal stresses

(or forces) and shear strain. This laminate characteristic requires that  $A_{16} = A_{26} = 0$  in the extensional stiffness matrix. The  $\bar{Q}_{16}$  and  $\bar{Q}_{26}$  terms from (5.24) are rewritten below

$$\begin{aligned}\bar{Q}_{16} &= (Q_{11} - Q_{12} - 2Q_{66}) \cos^3 \theta \sin \theta - (Q_{22} - Q_{12} - 2Q_{66}) \cos \theta \sin^3 \theta \\ \bar{Q}_{26} &= (Q_{11} - Q_{12} - 2Q_{66}) \cos \theta \sin^3 \theta - (Q_{22} - Q_{12} - 2Q_{66}) \cos^3 \theta \sin \theta\end{aligned}\quad (7.47)$$

For cross-ply laminates all plies have reinforcing fibers at either  $0^\circ$  or  $90^\circ$  off-set angles with respect to the reference XY coordinate system. Of course, unidirectional laminates have all reinforcement oriented along the  $0^\circ$  reference coordinate direction. For these special laminates it easily follows from (7.47) that  $\bar{Q}_{16}$  and  $\bar{Q}_{26}$  are both zero valued for either  $\theta = 0^\circ$  or  $\theta = 90^\circ$ . The stiffness terms of interest are written as

$$\begin{aligned}A_{16} &= \sum_{K=1}^n (\bar{Q}_{16})_K (h_K - h_{K-1}) \\ A_{26} &= \sum_{K=1}^n (\bar{Q}_{26})_K (h_K - h_{K-1})\end{aligned}\quad (7.48)$$

Since the identified  $\bar{Q}$  terms are all zero valued for unidirectional and cross-ply laminates, the  $A_{16}$  and  $A_{26}$  extensional stiffness terms are also zero valued. Thus these special laminates behave as orthotropic layers with respect to in-plane forces.

In the case of angle ply laminates, for every lamina (ply) with fiber reinforcement oriented at  $+\theta$  with respect to reference coordinates there is a lamina with identical constitutive properties and thickness oriented at an off-set angle of  $-\theta$ . Because the constitutive terms  $\bar{Q}_{16}$  and  $\bar{Q}_{26}$  are odd functions of  $\theta$  as shown in (7.47), these two layers contribute equal positive and negative quantities to the extensional stiffness terms  $A_{16}$  and  $A_{26}$ . Thus these extensional stiffness terms are zero valued for angle ply laminates. Therefore angle ply laminates act as specially orthotropic layers with respect to in-plane forces and strains. Note that the relative position of these lamina pairs, i.e., with respect to the geometric mid-plane of the laminate, is immaterial. It follows that it is possible to construct a symmetric laminate, which exhibits an identically zero coupling stiffness matrix  $[B]$ , which at the same time is specially orthotropic with respect to in plane forces and strains ( $A_{16} = A_{26} = 0$ ).

Simplification of the bending stiffness matrix  $[D]$ , which is defined in (7.20), can also be considered for these special laminates. The contribution of a ply to a particular term in  $[D]$  comes from the product of the appropriate term in  $[\bar{Q}]$  and the difference in the cubes of the z coordinate of the upper and lower ply interfaces. Since the contribution of the geometric term  $(h_K^3 - h_{K-1}^3)$  is always positive, this results in the  $D_{11}, D_{22}, D_{12}$  and

$D_{66}$  terms all being positive valued. Because the  $\bar{Q}_{16}$  and  $\bar{Q}_{26}$  are odd functions of  $\theta$ , the  $D_{16}$  and  $D_{26}$  terms in the bending stiffness matrix can be zeroed out. This result is accomplished by having all plies in the laminate oriented at either  $0^\circ$  or  $90^\circ$  or if for every ply oriented at  $+\theta$  above the geometric mid-plane there is an identical ply at an equal distance below the mid-plane oriented at  $-\theta$ . Of course laminates of the latter type do not exhibit mid-plane symmetry and thus the coupling stiffness matrix  $[B]$  is nonzero in this case. Thus the only mid-plane symmetric laminates, for which the bending stiffness terms  $D_{16}$  and  $D_{26}$  are identically zero, are those that have every ply oriented at either  $0^\circ$  or  $90^\circ$ . It should be noted that for a laminate with alternate plies at equal positive and negative values of  $\theta$ , the  $D_{16}$  and  $D_{26}$  terms approach zero as the number of plies (laminae) increase.

### 7.4.3 Quasiisotropic Laminates

A laminate construction widely utilized in many design applications is denoted quasiisotropic. In this construction, the ply lay-up results in the extensional stiffness matrix exhibiting isotropic material behavior. These laminate constructions do not, however, result in isotropic behavior with regard to the coupling and bending stiffness matrices,  $[B]$  and  $[D]$  respectively. This means that the elastic coefficients  $A_{ij}$  are independent of orientation in the plane of the laminate. In this case there are only two independent elastic coefficients similar to those in the stiffness matrix of an isotropic material. Stiffness terms for the quasiisotropic laminate must satisfy certain relationships in order to be consistent with the stiffness terms for an isotropic material. These relationships are as follows

$$\begin{aligned} A_{11} &= A_{22} \\ A_{11} - A_{12} &= 2A_{66} \\ A_{16} &= A_{26} = 0 \end{aligned} \quad (7.49)$$

The first of these expressions simply says that the extensional modulus is independent of orientation. The second expression in (7.49) is analogous to the following relationship for isotropic materials, i.e.,

$$\frac{E}{1-\nu^2} - \frac{\nu E}{1-\nu^2} = 2G$$

rearranging gives

$$\frac{E}{(1-\nu)(1+\nu)}(1-\nu) = 2G$$

and simplifying provides the well known relationship for isotropic materials

$$G = \frac{E}{2(1 + \nu)}$$

Here the isotropic material terms include  $E$  (Young's modulus),  $\nu$  (Poisson's ratio) and  $G$  (shear modulus). The last expression in (7.49) represents the fact that there is no coupling between extensional and in-plans shear strain for the quasiisotropic laminate. The construction of a quasiisotropic laminate has the following requirements

- (1)  $n \geq 3$ , where  $n$  represents the number of plies in the laminate
- (2) Individual plies must be of equal thickness and equal stiffness  $[Q]_k$  values
- (3) Plies must be oriented at equal angles, i.e.  $\theta_k - \theta_{k-1} = \pi/n$

Thus the angle between two adjacent plies should have the value of  $\pi/n$ . Examples would include the three ply laminate  $[0^\circ / \pm 60^\circ]$  and the four ply laminate  $[0^\circ / \pm 45^\circ / 90^\circ]$ . Note that for laminates constructed with sets of three or more plies each, the plies in each set must satisfy the above stated condition on orientation. An example would be the eight ply laminate  $[0^\circ / \pm 45^\circ / 90^\circ]_S$ .

It is important to note that the strength properties of quasiisotropic laminates are still directionally dependent even in the plane of the laminate.

## 7.5 Some Examples of Laminate Analysis

Two different laminate geometries are considered along with different combinations of applied and thermal loads. The first laminate is a two-ply  $[45/0]$  construction and the second is an eight-ply  $[0/45/-45/90]_S$  symmetric construction. Note that plies made from unidirectional pre-impregnated tape are generally on the order of 0.125 mm (0.005 in.) thick. The ply thicknesses specified in the following examples are larger than the typical tape thickness, thus each ply in the examples might be thought of as a number of tape lay-ups with the same fiber orientation. The properties used in these examples are those of a typical E-glass epoxy. Some of these properties have been used in earlier examples, but all of the properties are listed below.

$$V_f = 0.45 \quad (\text{volume fiber fraction})$$

$$\rho = 1.8 \text{ g/cm}^3 \quad (\text{density})$$

Elastic Moduli (Natural Coordinates)

$$E_L = 38.6 \text{ GPa} (5.6 \text{ MPsi})$$

$$E_T = 8.27 \text{ GPa} (1.20 \text{ MPsi})$$

$$G_{LT} = 4.14 \text{ GPa} (0.60 \text{ MPsi})$$

Major Poisson's Ratio

$$\nu_{LT} = 0.26$$

Thermal Expansion Coefficients (Natural Coordinates)

$$\alpha_L = 8.60 \times 10^{-6} / ^\circ \text{C}$$

$$\alpha_T = 22.10 \times 10^{-6} / ^\circ \text{C}$$

Strength Properties

$$\sigma_{LU} = 1062 \text{ MPa} (154.1 \text{ KPsi})$$

$$\sigma'_{LU} = 610 \text{ MPa} (88.5 \text{ KPsi})$$

$$\sigma_{TU} = 31 \text{ MPa} (4.5 \text{ KPsi})$$

$$\sigma'_{TU} = 118 \text{ MPa} (17.1 \text{ KPsi})$$

$$\tau_{LTU} = 72 \text{ MPa} (10.45 \text{ KPsi})$$

### 7.5.1 Two-Ply [45/0] Laminate Subjected to Applied Loads

The top lamina with thickness 3mm has a  $45^\circ$  orientation with respect to reference XY coordinates while the bottom lamina of thickness 5mm has a  $0^\circ$  orientation. Thus the laminate has a total thickness of 8mm. The applied loads are  $N_x = 300 \text{ N/mm}$  and  $N_y = 150 \text{ N/mm}$ . Based on the given properties, the stiffness matrix  $[Q]$  is identical for each ply and is determined from equations (3.20) as

$$[Q] = \begin{bmatrix} 39.167 & 2.1818 & 0 \\ 2.1818 & 8.3915 & 0 \\ 0 & 0 & 4.14 \end{bmatrix} \text{ GPa}$$

The  $[Q]$  and  $[\bar{Q}]$  stiffness matrices are identical for the  $0^\circ$  ply thus

$$[\bar{Q}]_{0^\circ} = [Q]$$

However,  $[\bar{Q}]$  for the  $45^\circ$  ply is determined using equations (5.24) and becomes

$$[\bar{Q}]_{45^\circ} = \begin{bmatrix} 17.121 & 8.8406 & 7.6939 \\ 8.8406 & 17.121 & 7.6939 \\ 7.6939 & 7.6939 & 10.799 \end{bmatrix} \text{ GPa}$$

The extensional  $[A]$ , coupling  $[B]$  and bending  $[D]$  stiffness matrices for the laminate can now be determined using equations (7.16), (7.17) and (7.20) respectively. The z-coordinate ( $h$  values) in these equations are  $h_0 = -4\text{mm}$ ,  $h_1 = -1\text{mm}$  and  $h_2 = +4\text{mm}$ . The laminate stiffness matrices are defined below in basic Newton and meter units. Thus the units of  $[A]$  are N/m,  $[B]$  are N and  $[D]$  are Nm. The laminate stiffness matrices in this example are given here as

$$[A] = \begin{bmatrix} 0.2472E+9 & 0.37431E+8 & 0.23082E+8 \\ 0.37431E+8 & 0.93319E+8 & 0.23082E+9 \\ 0.23082E+8 & 0.23082E+8 & 0.53096E+8 \end{bmatrix} \text{ N/m}$$

$$[B] = \begin{bmatrix} 0.16535E+6 & -0.49941E+5 & -0.57704E+5 \\ -0.49941E+5 & -0.65468E+5 & -0.57704E+5 \\ -0.57704E+5 & -0.57704E+5 & -0.49941E+5 \end{bmatrix} \text{ N}$$

$$[D] = \begin{bmatrix} 0.12082E+4 & 0.23292E+3 & 0.16157E+3 \\ 0.23292E+3 & 0.54135E+3 & 0.16157E+3 \\ 0.16157E+3 & 0.16157E+3 & 0.31647E+3 \end{bmatrix} \text{ Nm}$$

Substituting the applied loads and the laminate stiffness matrices into (7.21) and solving gives the mid-plane strains and curvatures as

$$\{\epsilon^o\} = \begin{Bmatrix} 0.0013845 \\ 0.0015448 \\ -0.00094981 \end{Bmatrix}$$

$$\{k\} = \begin{Bmatrix} -0.26586 \\ 0.20351 \\ 0.41605 \end{Bmatrix} \text{ 1/m}$$

Having the mid-plane strains and curvatures, the strains in reference  $XY$  coordinates are calculated using (7.6). These strains are given as

## MECHANICAL (ELASTIC) STRAINS IN XY COORDS. FOR PLY 1

EPX-UPPER	EPX-LOWER	EPY-UPPER	EPY-LOWER	EPXY-LOWER	EPXY-LOWER
0.24479E-02	0.16503E-02	0.73073E-03	0.13412E-02	-0.26140E-02	-0.13659E-02

## MECHANICAL (ELASTIC) STRAINS IN XY COORDS. FOR PLY 2

EPX-UPPER	EPX-LOWER	EPY-UPPER	EPY-LOWER	EPXY-LOWER	EPXY-LOWER
0.16503E-02	0.32100E-03	0.13412E-02	0.23588E-02	-0.13659E-02	0.71438E-03

The stresses in reference XY coordinates are the determined from (5.21) or (7.9) for each ply. In this example these stresses are given below.

## STRESSES IN REFERENCE XY COORDS. FOR PLY 1

SX-UPPER	SX-LOWER	SY-UPPER	SY-LOWER	SXY-UPPER	SXY-LOWER
28.258	29.603	14.039	27.044	-3.7720	8.2672

## STRESSES IN REFERENCE XY COORDS. FOR PLY 2

SX-UPPER	SX-LOWER	SY-UPPER	SY-LOWER	SXY-UPPER	SXY-LOWER
67.565	17.719	14.856	20.494	-5.6547	2.9575

Stresses are transformed to natural (material) coordinates for each ply using equation (5.1). We have

## STRESSES IN NATURAL LT COORDS. FOR PLY 1

SL-UPPER	SL-LOWER	ST-UPPER	ST-LOWER	SLT-UPPER	SLT-LOWER
17.377	36.591	24.921	20.056	-7.1091	-1.2795

## STRESSES IN NATURAL LT COORDS. FOR PLY 2

SL-UPPER	SL-LOWER	ST-UPPER	ST-LOWER	SLT-UPPER	SLT-LOWER
67.565	17.719	14.856	20.494	-5.6547	2.9575

Note that these stresses are all given in units of MPa. The nomenclature in these results is that SX, SY, and SXY represent the stresses in the reference XY directions and SL, ST, and SLT the longitudinal (along the fiber reinforcement) and transverse (perpendicular to the fiber reinforcement) directions, i.e., natural coordinates. The SXY and SLT terms represent shear stresses in the respective coordinate systems. Remember that it is important to be able transform the stresses to natural coordinates for the purposes of performing failure analysis.

The strains in natural coordinates are obtained from equation (3.19) as presented below.

STRAINS IN NATURAL LT COORDS. FOR PLY 1

EL-UPPER	EL-LOWER	ET-UPPER	ET-LOWER	ELT-UPPER	ELT-LOWER
0.28231E-03	0.81285E-03	0.28963E-02	0.21787E-02	-0.17172E-02	-0.30907E-03

STRAINS IN NATURAL LT COORDS. FOR PLY 2

EL-UPPER	EL-LOWER	ET-UPPER	ET-LOWER	ELT-UPPER	ELT-LOWER
0.16503E-02	0.32100E-03	0.13412E-02	0.23588E-02	-0.13659E-02	0.71438E-03

The stresses in reference  $XY$  coordinates are plotted in Figure 7.6 over a cross section of the laminate.

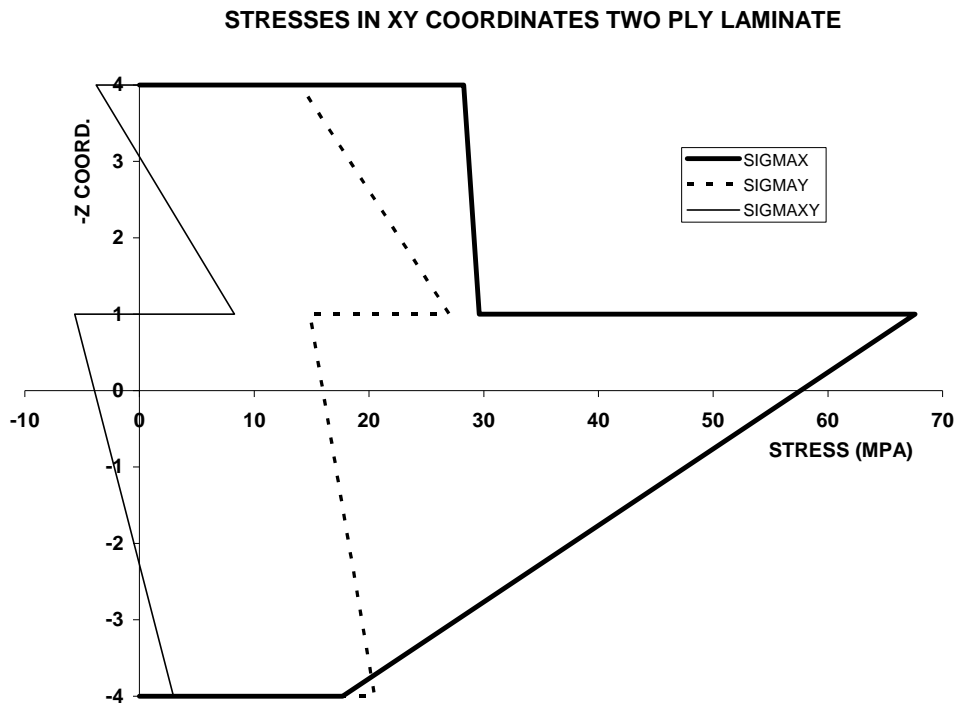
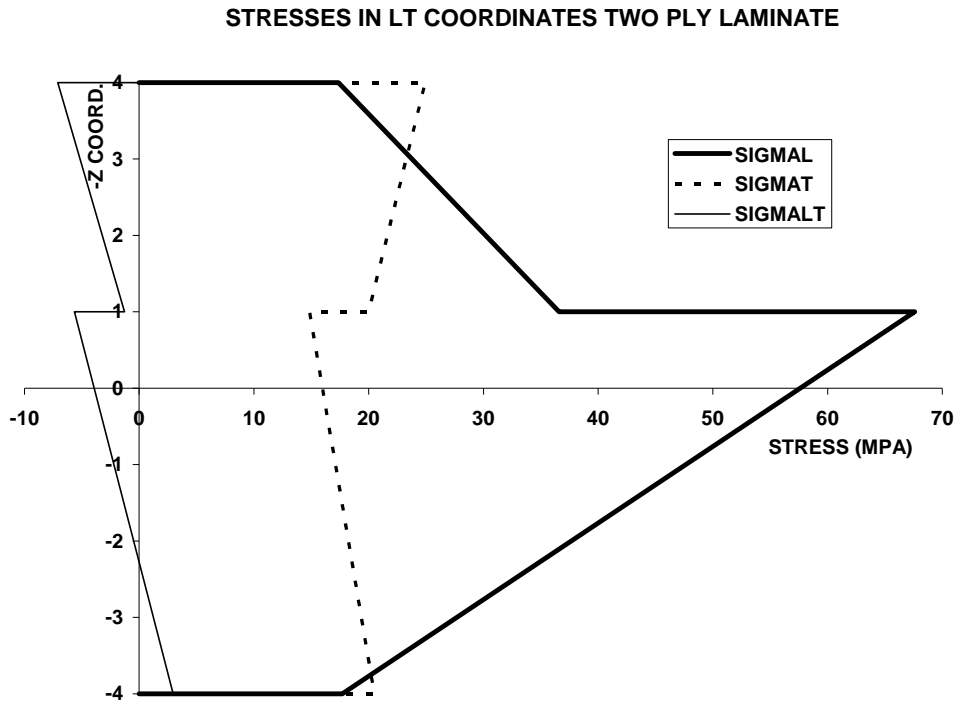

**Figure 7.6 Stress Variation for Two-Ply [45/0] Laminate, Reference Coords.**

This graphical representation of stress variation clearly shows that the maximum stress in reference coordinates occur at the upper interface of the lower  $0^\circ$  ply. Stresses in natural (material) coordinates are plotted for this two-ply laminate in Figure 7.7 below. This plot also shows that the maximum stress in natural coordinates occurs at the upper face of the lower  $0^\circ$  ply. Applying the maximum stress criteria to these results, the most critical stress is the transverse tensile stress at the upper surface of the  $45^\circ$  ply. We have

$$\frac{\sigma_T}{\sigma_{TU}} = 0.804 < 1.0$$

Thus the applied loads are not predicted to produce failure in this two-ply laminate. Applications of the alternative failure theories predict no failure in this example as well. The fact that the transverse tensile stress is most critical is due to the low transverse strength of the matrix. This is commonly the first type of damage observed in laminated composite materials and the damage is exhibited as cracks in the matrix running parallel to the reinforcing fibers.



**Figure 7.7 Stress Variation for Two-Ply [45/0] Laminate, Natural Coords.**

### 7.5.2 Two-Ply [45/0] Laminate Subjected to Thermal Load Only

The laminate geometry is unchanged in this example. The intent is to calculate the residual stresses caused by the fabrication process. It is assumed that the laminate is processed at a fabrication temperature of 175°C and cooled to room temperature of 25°C. Thus the change in temperature for calculation purposes is

$$\Delta T = -150^{\circ}C$$

The ply stiffness matrices  $[Q]$ ,  $[\bar{Q}]$  and the laminate stiffness matrices  $[A]$ ,  $[B]$ , and  $[D]$  are unchanged from the previous example. The coefficients of thermal expansion must be transformed from natural coordinates to reference XY coordinates for each ply using equations (7.31). This gives

$$\begin{Bmatrix} \alpha_X \\ \alpha_Y \\ \alpha_{XY} \end{Bmatrix}_{45^\circ} = \begin{Bmatrix} 15.35 \\ 15.35 \\ -13.5 \end{Bmatrix} \times 10^{-6} \quad /^\circ C$$

$$\begin{Bmatrix} \alpha_X \\ \alpha_Y \\ \alpha_{XY} \end{Bmatrix}_{0^\circ} = \begin{Bmatrix} 8.6 \\ 22.1 \\ 0 \end{Bmatrix} \times 10^{-6} \quad /^\circ C$$

for the upper  $45^\circ$  and lower  $0^\circ$  plies, respectively. The apparent thermal forces and moments are then obtained from equations (7.38) and (7.42) and are given below.

$$\begin{Bmatrix} N_X^T \\ N_Y^T \\ N_{XY}^T \end{Bmatrix} = \begin{Bmatrix} -0.42138 \\ -0.28575 \\ -0.040689 \end{Bmatrix} \times 10^{+6} \quad N/m$$

$$\begin{Bmatrix} M_X^T \\ M_Y^T \\ M_{XY}^T \end{Bmatrix} = \begin{Bmatrix} -101.72 \\ +101.72 \\ +101.72 \end{Bmatrix} \quad Nm/m$$

Substituting the apparent thermal loads and moments into and the laminate stiffness matrices into (7.21) gives the mid-plane strains and curvatures as

$$\{\epsilon^o\} = \begin{Bmatrix} -0.001533 \\ -0.002907 \\ +0.0007915 \end{Bmatrix}$$

$$\{k\} = \begin{Bmatrix} +0.12164 \\ -0.17239 \\ -0.33743 \end{Bmatrix} \quad 1/m$$

The mid-plane strains and curvatures can be substituted into (7.34) to obtain the mechanical (elastic) strains for each ply. These strains are given here as

MECHANICAL STRAINS IN REFERENCE XY COORDS. FOR PLY 1

EPX-UPPER    EPX-LOWER    EPY-UPPER    EPY-LOWER    EPXY-LOWER    EPXY-LOWER

0.28270E-03    0.64761E-03    0.84742E-04    -0.43244E-03    0.11626E-03    -0.89604E-03

## MECHANICAL STRAINS IN REFERENCE XY COORDS. FOR PLY 2

EPX-UPPER	EPX-LOWER	EPY-UPPER	EPY-LOWER	EPXY-LOWER	EPXY-LOWER
-0.36489E-03	0.24329E-03	0.58006E-03	-0.28190E-03	0.11290E-02	-0.5582E-03

The stresses in reference *XY* coordinates are determined from (7.36) for each ply and are listed below.

## STRESSES IN REFERENCE XY COORDS. FOR PLY 1

SX-UPPER	SX-LOWER	SY-UPPER	SY-LOWER	SXY-UPPER	SXY-LOWER
6.484	0.370	4.845	-8.572	4.082	-8.021

## STRESSES IN REFERENCE XY COORDS. FOR PLY 2

SX-UPPER	SX-LOWER	SY-UPPER	SY-LOWER	SXY-UPPER	SXY-LOWER
-13.026	8.914	4.072	-1.835	4.674	-2.311

Stresses are transformed to natural (material) coordinates for each ply through (5.1).

## STRESSES IN NATURAL LT COORDS. FOR PLY 1

SL-UPPER	SL-LOWER	ST-UPPER	ST-LOWER	SLT-UPPER	SLT-LOWER
9.747	-12.122	1.582	3.920	-0.820	-4.471

## STRESSES IN NATURAL LT COORDS. FOR PLY 2

SL-UPPER	SL-LOWER	ST-UPPER	ST-LOWER	SLT-UPPER	SLT-LOWER
-13.026	8.914	4.072	-1.835	4.674	-2.311

The stresses are all defined in units of MPa. The strains in natural coordinates are obtained by solving (3.19).

## STRAINS IN NATURAL LT COORDS. FOR PLY 1

EL-UPPER	EL-LOWER	ET-UPPER	ET-LOWER	ELT-UPPER	ELT-LOWER
0.24185E-03	-0.34044E-03	0.12559E-03	0.55561E-03	-0.19796E-03	-0.10800E-02

## STRAINS IN NATURAL LT COORDS. FOR PLY 2

EL-UPPER	EL-LOWER	ET-UPPER	ET-LOWER	ELT-UPPER	ELT-LOWER
-0.36489E-03	0.24329E-03	0.58006E-03	-0.28190E-03	0.11290E-02	-0.5582E-03

For this case of thermal loads only, the residual stresses in reference coordinates are plotted below in Figure 7.8 over a cross section of the laminate. In this graphical representation it is clear that the largest stress is compressive and acts at the interface between plies. Note that the variation of  $\sigma_x$ ,  $\sigma_y$ , and  $\tau_{xy}$  are self-equilibrating which is consistent with the fact that there are no external applied forces/moments in this example. Thus the net area in each of these stress plots, in reference coordinates, and the moment of the area about any point is zero.

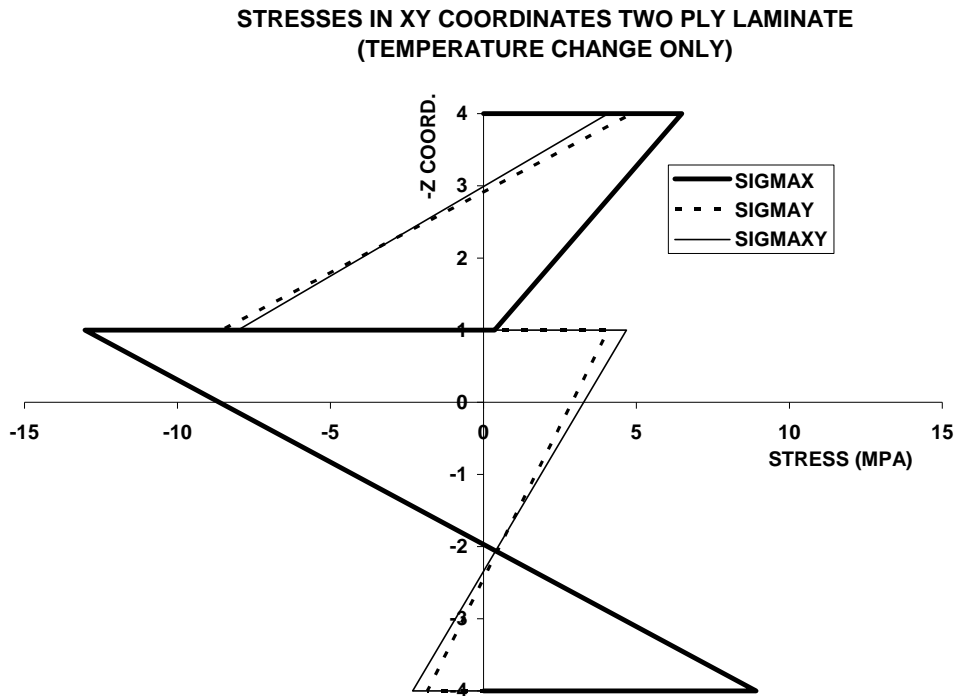
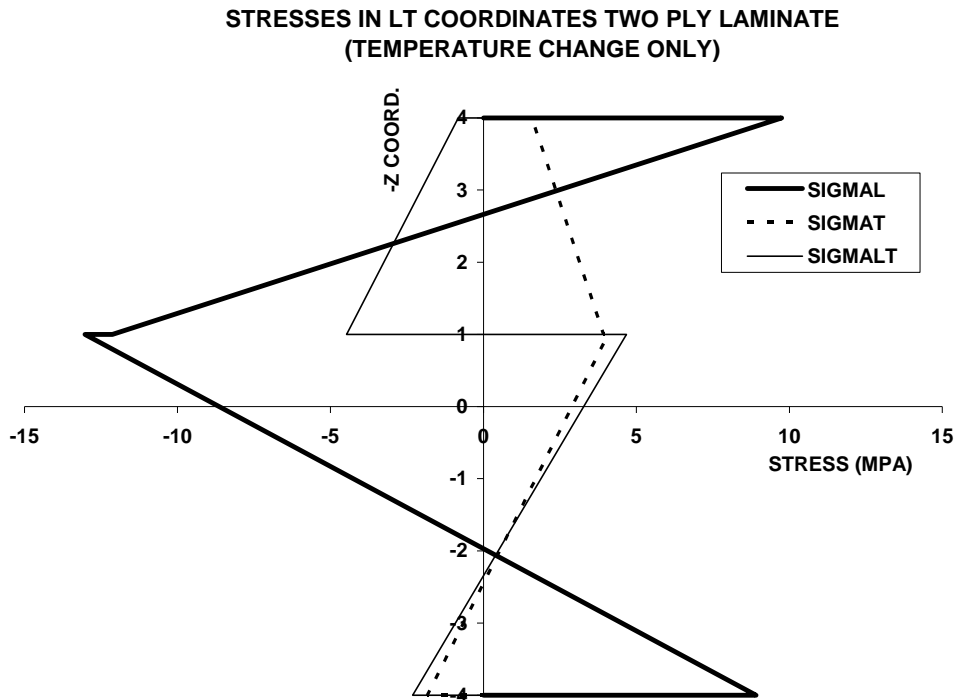

**Figure 7.8 Residual Stress Variation for Two-Ply [45/0]  
Laminate, Reference Coordinates**

Residual stresses in natural coordinates are plotted below in Figure 7.9. The largest stress in natural coordinates is compressive and occurs at the upper interface of the  $0^\circ$  ply. Applying the maximum stress criteria in this case, the most critical stress is the transverse tensile stress at the upper interface of the  $0^\circ$  ply. This criteria is written as

$$\frac{\sigma_T}{\sigma_{TU}} = 0.131 < 1$$

Therefore the residual thermal stresses produced in this example are quite low and not predicted to produce failure. Alternative failure theories also predict that these stresses are quite safe.



### 7.5.3 Two-Ply [45/0] Laminate Subjected to Applied and Thermal Loads

In this example the applied and apparent thermal loads of the previous two example problems are combined. Thus in this case the governing equations (7.21) are solved for the mid-plane strains and curvatures where the loads  $\{N\}$  and moments  $\{M\}$  contain both the applied and the apparent thermal loads/moments as defined in (7.45) and (7.46). Mid-plane strains and curvatures are substituted into (7.34) to obtain the mechanical (elastic) strains for each ply. Stresses in reference XY coordinates come from (7.36) and are transformed to natural coordinates for each ply using the transformation (5.1). Strains in natural coordinates come from (3.19). The stresses in reference XY coordinates are plotted below in Figure 7.10 through a cross section of the laminate. Stresses in natural coordinates are plotted in Figure 7.11. Applying the maximum stress criteria, the most critical stress is the transverse tensile stress at the upper surface of the  $45^\circ$  ply. We have

$$\frac{\sigma_T}{\sigma_{TU}} = 0.855 < 1$$

Thus the combined loads are not predicted to produce failure.

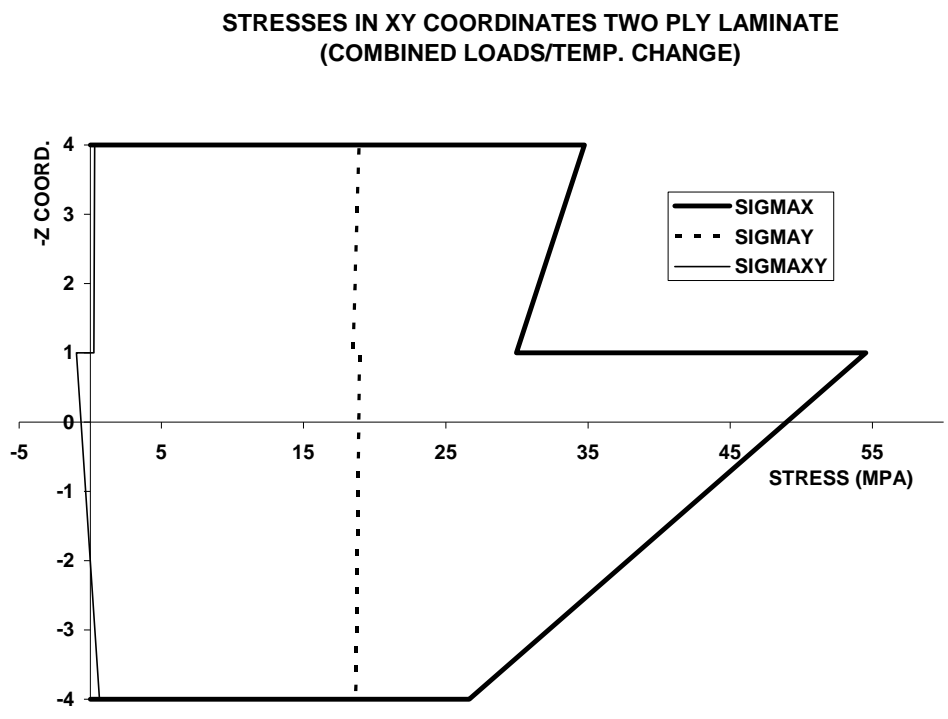

**Figure 7.10 Stress Variation for [45/0] Laminate, Ref. Coords., Combined Loads**

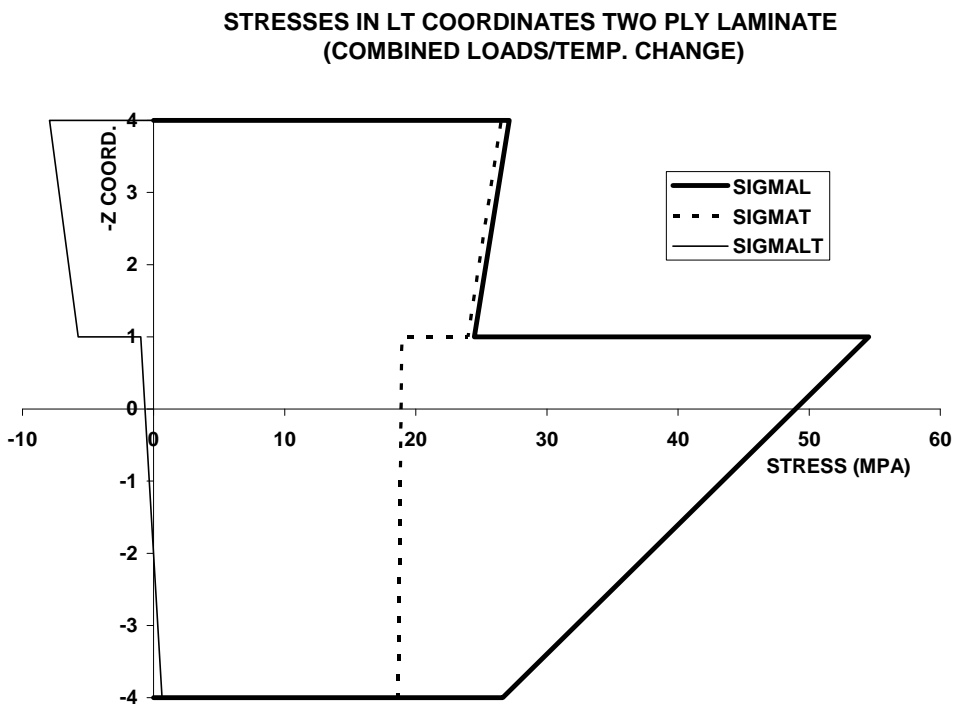

**Figure 7.11 Stress Variation for [45/0] Laminate, Natural Coords., Combined Loads**

#### 7.5.4 Quasiisotropic $[0,45,-45,90]_S$ Laminate Subjected to Applied Loads

This symmetric laminate is comprised of eight plies where each ply is 0.25 mm thick. Thus the laminate has a thickness of 3 mm. The applied loads in this case are  $N_x = 100N/mm$  and  $N_y = 50N/mm$ . Based on the given E-glass epoxy properties, the stiffness matrix  $[Q]$  is identical for each ply and has been previously defined in section 7.5.1. The  $[Q]$  and  $[\bar{Q}]$  matrices are identical for the  $0^\circ$  ply. The  $[\bar{Q}]$  matrix for the  $45^\circ$  ply has also been previously defined. The  $[\bar{Q}]$  stiffness matrices for the  $-45^\circ$  and  $90^\circ$  off-axis plies are defined using equation (5.24) and are written below.

$$[\bar{Q}]_{-45^\circ} = \begin{bmatrix} 17.121 & 8.8406 & -7.6939 \\ 8.8406 & 17.121 & -7.6939 \\ -7.6939 & -7.6939 & 10.799 \end{bmatrix} \text{ GPa}$$

$$[\bar{Q}]_{90^\circ} = \begin{bmatrix} 8.3915 & 2.1818 & 0 \\ 2.1818 & 39.167 & 0 \\ 0 & 0 & 4.14 \end{bmatrix} \text{ GPa}$$

The extensional  $[A]$ , coupling  $[B]$  and bending  $[D]$  laminate stiffness matrices are defined using equations (7.16), (7.17) and (7.20) respectively. The z-coordinate ( $h$  values) locating the upper and lower interfaces of each ply are given as

$$\begin{aligned} h_0 &= -1.0\text{mm}, h_1 = -0.75\text{mm}, h_2 = -0.50\text{mm}, h_3 = -0.25\text{mm}, h_4 = 0.00\text{mm} \\ h_5 &= 0.25\text{mm}, h_6 = 0.50\text{mm}, h_7 = 0.75\text{mm}, h_8 = 1.0\text{mm} \end{aligned}$$

The laminate stiffness matrices are defined in basic Newton and meter units. These matrices in this example are as follows

$$[A] = \begin{bmatrix} 0.40900E+8 & 0.11022E+8 & 0.0 \\ 0.11022E+8 & 0.40900E+8 & 0.0 \\ 0.0 & 0.0 & 0.14939E+8 \end{bmatrix} \text{ N/m}$$

$$[D] = \begin{bmatrix} 19.82 & 3.258 & 0.96174 \\ 3.258 & 8.2791 & 0.96174 \\ 0.96174 & 0.96174 & 4.5634 \end{bmatrix} \text{ Nm}$$

The coupling stiffness matrix  $[B]$  is numerically zero-valued because the laminate stacking sequence is symmetric. Since this is a quasiisotropic laminate, terms in the extensional stiffness matrix  $[A]$  satisfy the relationships given in (7.49) for isotropic material behavior. Substituting the applied loads along with the laminate stiffness matrices into (7.21) and solving gives the mid-plane strains as

$$\{\boldsymbol{\varepsilon}^o\} = \begin{Bmatrix} 0.0022812 \\ 0.0006077 \\ 0.0000000 \end{Bmatrix}$$

The plate curvatures  $\{k\}$  are numerically zero-valued in this case due to the fact that there is no coupling between in-plane loads and bending. Following the same procedure as in the previous examples, the mid-plane strains are substituted into (7.6) to solve for strains in reference coordinates. Stresses in reference coordinates are determined from (5.21) and these stresses are transformed to natural coordinates for each ply using equation (5.1) or (7.9). These stresses in natural coordinates are written below for the four plies above the geometric mid-plane of the laminate.

STRESSES IN NATURAL LT COORDS. FOR PLY 1

SL-UPPER	SL-LOWER	ST-UPPER	ST-LOWER	SLT-UPPER	SLT-LOWER
90.675	90.675	10.077	10.077	0.000	0.000

STRESSES IN NATURAL LT COORDS. FOR PLY 2

SL-UPPER	SL-LOWER	ST-UPPER	ST-LOWER	SLT-UPPER	SLT-LOWER
59.727	59.727	15.273	15.273	-6.928	-6.928

STRESSES IN NATURAL LT COORDS. FOR PLY 3

SL-UPPER	SL-LOWER	ST-UPPER	ST-LOWER	SLT-UPPER	SLT-LOWER
59.727	59.727	15.273	15.273	6.928	6.928

STRESSES IN NATURAL LT COORDS. FOR PLY 4

SL-UPPER	SL-LOWER	ST-UPPER	ST-LOWER	SLT-UPPER	SLT-LOWER
28.780	28.780	20.469	20.469	0.000	0.000

Due to symmetry and the fact that only in-plane loads are applied to the laminate, the stresses in the four plies below the geometric mid-plane of the laminate are the mirror image of the stresses given above. Stresses in reference  $XY$  coordinates are plotted in Figure 7.12 over a cross section of the laminate. Stresses in natural (material) coordinates are similarly plotted in Figure 7.13. The largest stress is the longitudinal stress in the  $0^\circ$  ply. However, the most critical stress is the transverse tensile stress in the  $90^\circ$  ply. We have

$$\frac{\sigma_T}{\sigma_{TU}} = 0.660 < 1$$

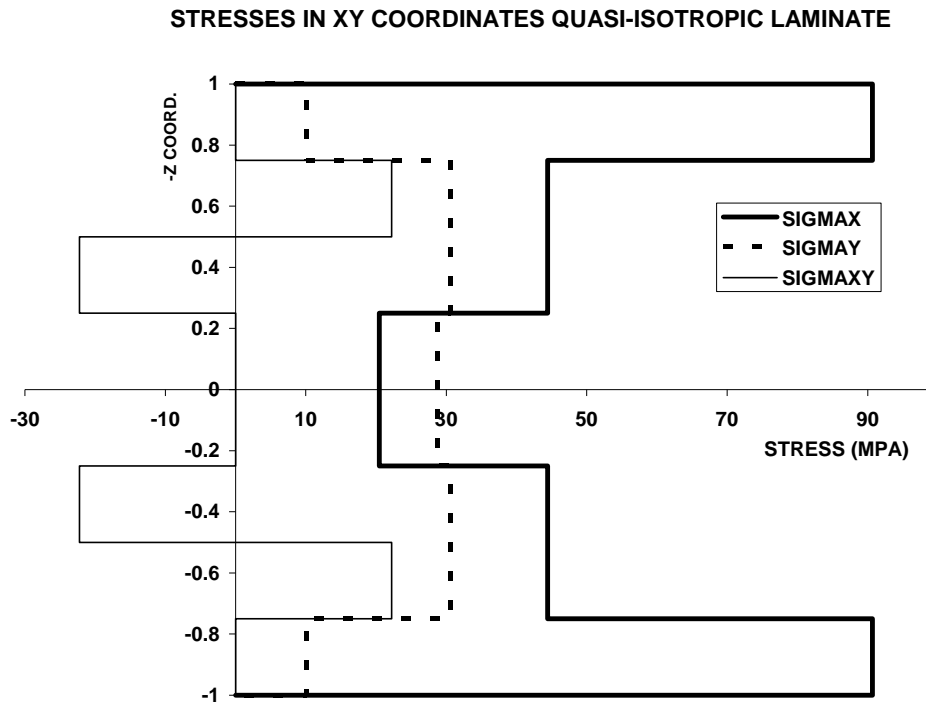

**Figure 7.12 Stress Variation for  $[0/45/-45/90]_s$  Laminate, Ref. Coords.**

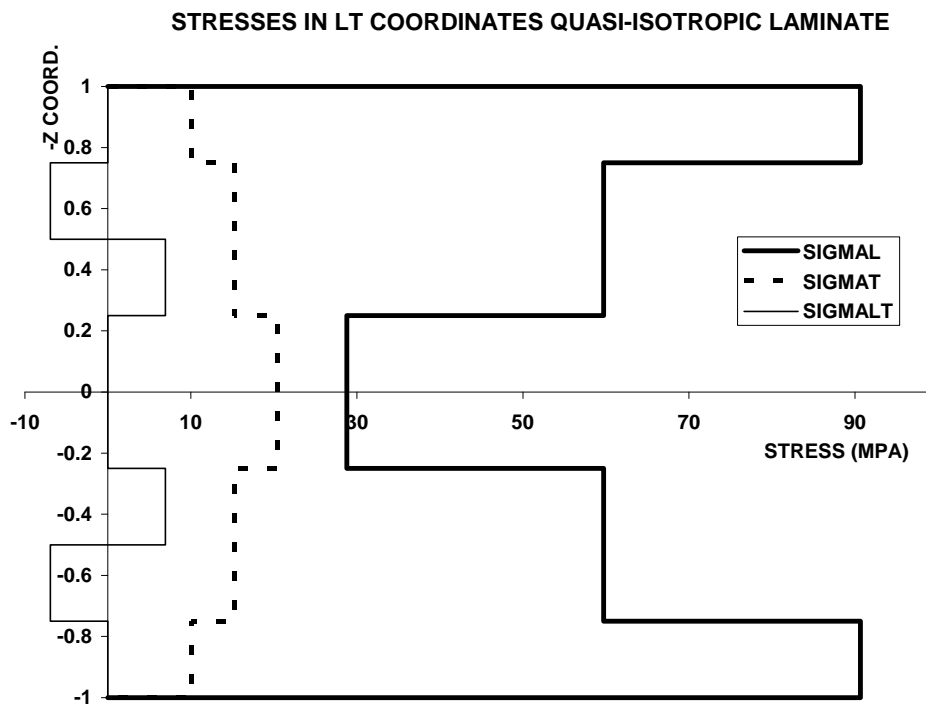

**Figure 7.13 Stress Variation for  $[0/45/-45/90]_s$  Laminate, Natural Coords.**

It is apparent that the applied loads are not predicted to produce failure in this quasiisotropic laminate. As in the previous examples, the low transverse tensile strength is the reason that transverse tensile stress is most critical. The first form of damage in this example would be observed as matrix cracking in the  $90^\circ$  plies.

## 8.0 SUMMARY

A well established computational method, based on *classical lamination theory*, for calculating stresses/strains in reinforced laminated composite structures has been presented. Furthermore, various failure theories have been defined, each of which utilizes the calculated stresses/strains on a ply-by-ply basis in the laminate. Externally applied loads and hygrothermal (thermal and moisture) effects have been included in the computational procedure. Stress and failure predictions are an integral part of the design process when specifying laminate geometries.

It has been noted that stress predictions from *classical lamination theory* are quite accurate in locations away from boundaries, e.g., free edges, edge of a hole or cutout, etc., of the laminate. Thus at distances equal to the laminate plate thickness or greater the computational method presented herein is accurate and useful in the preliminary design of laminated composite structures. The basis for this limitation is that lamination theory assumes a generalized state of plane stress which is reasonably accurate away from boundaries. Along boundaries, the state of stress becomes three-dimensional with the possibility that interlaminar shear and/or interlaminar normal stresses can become significant. Deviation of lamination theory along laminate boundaries is often referred to as a *boundary-layer phenomenon*. Computation of stresses along laminate boundaries is generally accomplished through the application of finite difference, finite element or boundary element computer programs and is beyond the scope of the methodology presented in this course.

## 9.0 REFERENCES

1. Whitney, J.M., N.J. Pagano and R.B. Pipes, "Design and Fabrication of Tubular Specimens for Composite Characterization," ASTM STP 497, American Society for Testing and Materials, 1972.
2. Whitney, J.M., D.L. Stansbarger and H.B. Howell, "Analysis of the Rail Shear Test-Applications and Limitations," *J. of Composite Materials*, pp. 24-34, 1971.
3. Walrath, D.E. and D.F. Adams, "The Iosipescu Shear Test As Applied to Composite Materials," *Experimental Mechanics*, 23(1), pp. 105-110, 1983.
4. Abdallah, M.G. and H.E. Gascoigne, "The Influence of Test Fixture Design of Iosipescu Shear Test for Fiber Composite Material," vol. 2, ASTM STP 1003, pp. 231-260, 1989.

5. Arcan, M, Z. Hashin and A. Voloshin, "A Method to Produce Uniform Plane-Stress States With Application to Fiber Reinforced Materials," *Experimental Mechanics*, 18(4), pp. 141-146, 1978.
6. Cain, K.J., Glinka, G. and A. Plumtree, "Damage Evolution in an Off-Axis Unidirectional Graphite Bismaleimide Composite Loaded in Tension," *Composites Part A: Applied Science and Engineering*, 34, pp. 987-993, 2003.
7. Van Paepegem, W., De Baere, I. and J. Degrieck, "Modelling the Nonlinear Shear Stress-Strain Response of Glass Fibre-Reinforced Composites. Part 1: Experimental Results," *Composites Science and Technology*, 66(10), pp. 1455-1464, 2006.
8. Sun, C.T. and I. Chung, "An oblique End-Tab Design for Testing Off-Axis Composite Specimens," *Composites*, 24(8), pp. 619-623, 1993.
9. Pierron, F. and A. Vautrin, "The 10 deg Off-Axis Tensile Test: A Critical Approach," *Composites Science and Technology*, 56, 483-488, 1996.
10. Pierron, F. and A. Vautrin, "New Ideas on the Measurement of the In-Plane Shear Strength of Unidirectional Composites," *J. of Composite Materials*, 31(9), 889-895, 1997.
11. Paris, F., "A Study of Failure Criteria of Fibrous Composite Materials," NASA/CR-2001-210661, Langley Research Center, March 2001.
12. Hashin, Z., "Failure Criteria for Unidirectional Fiber Composites," *J. of Applied Mechanics*, vol. 47, pp. 329-334, 1980.
13. Icardi, U., Locatto, S. and A. Longo, "Assessment of Recent Theories for Predicting Failure of Composite Laminates," *Transactions of the ASME*, 60, pp. 76-86, 2007.
14. Davila, C.G. and P.P. Camanho, "Failure Criteria for FRP Laminates in Plane Stress," NASA/TM-2003-212663, Langley Research Center, November 2003.
15. Sun, C.T., Quinn, B.J., Tao, J. and D.W. Oplinger, "Comparative Evaluation of Failure Analysis Methods for Composite Laminates," DOT/FAA/AR-95/109, 1996.
16. Hashin, Z. and A. Rotem, "A Fatigue Failure Criterion for Fiber Reinforced Materials," *J. of Composite Materials*, 7, pp. 448-464, 1973.

17. Chang, Fu-Kuo and Kuo-Yen Chang, "A Progressive Damage Model for Laminated Composites Containing Stress Concentrations," *J. of Composite Materials*, 21, pp. 834-855, 1987.
18. Shahid, I. and Fu-Kuo Chang, "An Accumulative Damage Model for Tensile and Shear Failures of Laminated Composite Plates," *J. of Composite Materials*, 29, pp. 926-981, 1995.
19. Hill, R., "The Mathematical Theory of Plasticity," Oxford University Press, London, 1950.
20. Tsai, S.W., "Strength Theories of Filamentary Structures," *Fundamental Aspects of Fiber Reinforced Plastic Composites*, Wiley Interscience, New York, R.T. Schwartz and H. S. Schwartz, Eds., pp. 3-11, 1968.
21. Agarwal, B.D. and J.N. Narang, "Strength and Failure Mechanism of Anisotropic Composites," *Fibre Science Technology*, 10(1), 37-52, 1977.
22. Tsai, S.W. and E.M. Wu, "A General Theory of Strength for Anisotropic Materials," *J. Composite Materials*, pp. 58-80, 1971.
23. Pipes, R., R. Byron and B.W. Cole, "On the Off-Axis Strength Test for Anisotropic Materials," *J. Composite Materials*, pp. 246-256, 1973.
24. Tsai S.W. and H.T. Hahn, "Introduction to Composite Materials," Technomic Publishing Co., pp. 280-287, 1980.
25. Jones, R.M., "Mechanics of Composite Materials," Scripta Book Co., Washington D.C., pp. 147-156, 1974.
26. Ashton, J.E., J.C. Halpin and P.H. Petit, "Primer on Composite Materials: Analysis," Technomic Publishing Co., Westport, Conn., 1969.